

Astaxanthin Production by *Phaffia rhodozyma*

Presented for the Degree of Master in Science

By

Tracy M. Barrins B.Sc (Hons)

Supervised by

Dr.M.A.Broaders

Submitted to the National Council for Educational Awards

June 1998

TABLE OF CONTENTS

TITLE	PAGE
Dedication	
Acknowledgements	
Abstract	
<u>CHAPTER ONE</u>	
1.0 Introduction	1
<u>CHAPTER TWO</u>	
2.0 Literature Review	
2.1 Introduction	4
2.2 Carotenoid Pigmentation of Salmonids	7
2.3 Carotenoids - in General	8
2.4 Astaxanthin : Function and Metabolism in Salmonids	10
2.5 Use of Synthetic Pigments - Current Pigmenting Practices	15
2.6 Crustacean Wastes as Astaxanthin Sources	18
2.7 Bacteria as Astaxanthin Sources	21
2.8 Plants and Algae as Astaxanthin Sources	23
2.9 Yeasts as Astaxanthin Sources	25
2.10 Developement of <i>Phaffia rhodozyma</i> as a Source of Astaxanthin	34
2.10.1 Culture Conditions	35
2.10.2 Nutrient Sources	38
2.10.3 Alternative Substrates and Carbon Sources	39
2.10.4 Cell Disruption	42
2.10.5 Developement of Novel Strains of <i>Phaffia rhodozyma</i>	50
2.10.6 Commercialisation of Astaxanthin Production by <i>Phaffia rhodozyma</i>	57

CHAPTER THREE

3.0	Materials and Methods	
3.1	Introduction	60
3.2	Shake Flask Culture System	60
3.2.1	Inoculum Preparation for Shake Flask Culture	61
3.2.2	pH Control	61
3.2.3	Sterilisation Procedure	61
3.2.4	Sampling Procedure	61
3.3	Laboratory Fermenter	62
3.3.1	Culture Vessel	63
3.3.2	pH Control	65
3.3.3	Aeration Control	65
3.3.4	Temperature Control	66
3.3.5	Agitation and Stirrer Control	66
3.3.6	Foam Control	66
3.3.7	Sterilisation Procedure	66
3.3.8	Sampling Procedure	67
3.3.9	Inoculum Preparation for Fermenter	67
3.4	Culture Conditions and Techniques	67
3.4.1	Maintenance of <i>Phaffia rhodozyma</i>	68
3.4.2	Preparation of Media	68
3.4.2.1	Comparison of Various Growth Media	69
3.4.2.2	Comparison of Carbon Concentrations	70
3.4.2.3	Addition of Fresh Substrate	71
3.4.2.4	Consumption of Carbon and Nitrogen Sources	71
3.4.2.5	Cultivation of the parent strain (NCYC 874) and a mutant strain (NRRL-Y-18734) of <i>Phaffia rhodozyma</i> in shake flask culture	72
3.4.2.6	Cultivation of the parent strain (NCYC 874) and a mutant strain (NRRL-Y-18734) of <i>Phaffia rhodozyma</i> in a laboratory fermenter	73
3.4.2.7	Preparation of Medium for Fermenter	74
3.5	Analytical Methods for Growth Analysis	74
3.5.1	Biomass Determination	74
3.5.2	Turbidity Measurements	75
3.5.3	Total Cell Count	76

3.5.4	Viable Cell Count	77
3.6	Growth Kinetics	78
3.6.1	Specific Growth Rate	79
3.7	Analytical Methods for the Extraction and Analysis of Astaxanthin from <i>Phaffia rhodozyma</i>	79
3.7.1	Mechanical Cell Breakage	80
3.7.1.1	Optimisation of Cell Breakage Procedure	80
3.7.1.2	Cell Breakage Procedure	81
3.7.2	Enzymatic Cell Breakage	82
3.7.2.1	Introduction	82
3.7.2.2	Optimisation of Cell Breakage Procedure	83
3.7.2.3	Cell Breakage Procedure	84
3.8	Analytical Techniques for the Analysis of Astaxanthin from <i>Phaffia rhodozyma</i>	86
3.8.1	Analysis of Astaxanthin Using Thin Layer Chromatography (T.L.C)	86
3.8.2	Analysis of Astaxanthin Using High Performance Liquid Chromatography (H.P.L.C)	88
3.8.2.1	Preparation of Standards	88
3.8.2.2	Sample Preparation	88
3.8.2.3	HPLC Conditions	89
3.9	Analysis of Culture Fluids	90
3.9.1	Introduction	90
3.9.2	Glucose Determination	91
3.9.3	Nitrogen Determination	92
3.10	Statistical Analysis	93
3.10.1	Range of Error of the Mean	93
3.10.2	Correlation	95

CHAPTER FOUR

4.0	Results	
4.1	Mechanical Cell Breakage	98
4.1.2	Analysis of Results	99
4.1.3	Cell to Bead Ratio Used in Cell Breakage Procedure	99
4.1.4	Volume of Solvent Used in Cell Breakage Procedure	100
4.2	Enzymatic Cell Breakage	100

4.2.1	Analysis of Results	101
4.3	Treatment of Yeast Cells Using Acid Lysis	105
4.3.1	Analysis of Results	105
4.4	Acid Lysis and Ezyme Treatment of <i>Phaffia rhodozyma</i> Cells	106
4.4.1	Analysis of Results	106
4.5	Comparison of Various Growth Media	109
4.5.1	Analysis of Results	109
4.6	Cultivation of the parent strain (NCYC 874) and a mutant strain of (NRRL-Y-18734) <i>Phaffia rhodozyma</i> in shake flask culture	115
4.6.1	Introduction	115
4.6.2	Analysis of Results	115
4.7	Effect of Supplementation of glucose on growth and pigment production by <i>Phaffia rhodozyma</i> grown in shake flask culture	157
4.7.1	Introduction	157
4.7.2	Analysis of Results	157
4.8	Cultivation of the parent strain (NCYC 874) and a mutant strain (NRRL-Y-18734) of <i>Phaffia rhodozyma</i> in a 2L Laboratory Fermenter	176
4.8.1	Introduction	176
4.8.2	Analysis of Results	176
4.8.3	HPLC Analysis of <i>Phaffia rhodozyma</i> Carotenoids	204
4.8.4	TLC Analysis of <i>Phaffia rhodozyma</i> Carotenoids	208

CHAPTER FIVE

5.0	Discussion of Results	
5.1	Mechanical and enzymatic cell breakage	211
5.2	Comaprison of various growth media	215
5.3	Effect of the addition of glucose on growth pigment production by <i>Phaffia rhodozyma</i> grown in batch culture	216
5.4	Cultivation of the parent strain (NCYC 874) and a mutant strain (NRRL-Y-18734) of <i>Phaffia rhodozyma</i> in shake flask culture	219

5.5	Cultivation of the parent strain (NCYC 874) and a mutant strain (NRRL-Y-18734) of <i>Phaffia rhodozyma</i> in a 2L fermenter	223
------------	---	------------

CHAPTER SIX

6.0	Conclusions	226
------------	--------------------	------------

REFERENCES	235
-------------------	------------

LIST OF TABLES

TITLE	PAGE	
Table 2.6.1	Natural Sources of Carotenoids Used in the Aquaculture Industry	18
Table 2.9.1	Carotenoids of <i>Phaffia rhodozyma</i>	30
Table 2.10.1	Methods of Cell Disruption	43
Table 2.10.2	Methods of Cell Disruption Used for <i>Phaffia rhodozyma</i>	43
Table 3.4.2.1.1	Composition of Yeast Malt Broth Medium	69
Table 3.4.2.1.2	Composition of Mineral Salts Medium	69
Table 3.4.2.1.3	Composition of Rich Assay Growth Medium	70
Table 3.4.2.1.4	Composition of Substitute Yeast Malt Broth Medium	70
Table 3.4.2.5	Division of cultivations of the parent strain (NCYC 874) and a mutant strain (NRRL-Y-18734) of <i>Phaffia rhodozyma</i> cultivated in a Yeast Malt Broth and Mineral Salts Medium	72
Table 3.8.2.3.1	Summary of HPLC Conditions Used in the Qualitative Analysis of <i>Phaffia rhodozyma</i> Carotenoids	89
Table 3.8.2.3.2	Summary of Chart Recorder Conditions Used in HPLC Analysis of <i>Phaffia rhodozyma</i> Carotenoids	90

Table 4.1.3.1	Effect of cell to bead ratio and volume of extraction solvent on the release of pigment from whole cells of <i>Phaffia rhodozyma</i>	99
Table 4.2.1	Percentage astaxanthin extracted from <i>Phaffia rhodozyma</i> cells after enzymatic treatment using three enzyme preparations	101
Table 4.3.1	Percentage extraction of astaxanthin from <i>Phaffia rhodozyma</i> cells after acid lysis using hydrochloric and sulphuric acid	106
Table 4.4.1.1	Percentage extraction of pigment from <i>Phaffia rhodozyma</i> cells after hot acid lysis with hydrochloric and sulphuric acid followed by enzyme treatment with SP 299 Mutanase	107
Table 4.5.1.1	Specific growth rates obtained for <i>Phaffia rhodozyma</i> cultured in various growth media	114
Table 4.6.2.1	Coefficients of correlation calculated for biomass and astaxanthin production by the parent strain and a mutant strain of <i>Phaffia rhodozyma</i>	148
Table 4.6.2.2	Correlation coefficients calculated for astaxanthin production and growth by the parent and mutant strain of <i>Phaffia rhodozyma</i>	149
Table 4.6.2.3	Correlation coefficients for biomass production and growth for the parent and mutant strain of <i>Phaffia rhodozyma</i>	150
Table 4.6.2.4	Correlation coefficients for glucose consumption and pigment production for the parent and mutant strain of <i>Phaffia rhodozyma</i>	151

Table 4.6.2.5	Correlation coefficients for glucose consumption and biomass production for the parent and mutant strain of <i>Phaffia rhodozyma</i>	152
Table 4.6.2.6	Correlation coefficients for glucose consumption and growth of the parent and mutant strain of <i>Phaffia rhodozyma</i>	153
Table 4.6.2.7	Correlation coefficients calculated for nitrogen consumption and astaxanthin production for the parent and mutant strain of <i>Phaffia rhodozyma</i>	153
Table 4.6.2.8	Correlation coefficients calculated for nitrogen consumption and biomass production for the parent and mutant strain of <i>Phaffia rhodozyma</i>	154
Table 4.6.2.9	Correlation coefficients calculated for consumption of nitrogen and growth of the parent and mutant strain of <i>Phaffia rhodozyma</i>	155
Table 4.6.2.10	Correlation coefficients calculated for nitrogen consumption and glucose consumption for the parent and mutant strain of <i>Phaffia rhodozyma</i>	155
Table 4.7.2.1	Correlation coefficients calculated for the control cultivation using a 1% carbon source	171
Table 4.7.2.2	Correlation coefficients calculated for the control cultivation using a 1.5% carbon source	172
Table 4.7.2.3	Correlation coefficients calculated for the supplemented cultivation when a 1% carbon source was used	173
Table 4.7.2.4	Correlation coefficients calculated for the supplemented cultivation where a 1.5% carbon source was used	174

Table 4.8.2.1	Culture conditions during the cultivation of the parent strain of <i>Phaffia rhodozyma</i> in a 2l laboratory fermenter	177
Table 4.8.2.2	Culture conditions during the cultivation of the mutant strain of <i>Phaffia rhodozyma</i> in a 2l laboratory fermenter	178
Table 4.8.2.3	Coefficients of correlation calculated for biomass and astaxanthin by the parent and a mutant strain of <i>Phaffia rhodozyma</i> grown in a 2l fermenter	198
Table 4.8.2.4	Coefficients of correlation calculated for growth and pigment production by the parent and a mutant strain of <i>Phaffia rhodozyma</i> grown in a 2l fermenter	199
Table 4.8.2.5	Coefficients of correlation calculated for growth and biomass production by the parent and a mutant strain of <i>Phaffia rhodozyma</i> grown in a 2l fermenter	200
Table 4.8.2.6	Coefficients of correlation calculated for glucose consumption and astaxanthin production by the parent and a mutant strain of <i>Phaffia rhodozyma</i> grown in a 2l fermenter	200
Table 4.8.2.7	Coefficients of correlation calculated for glucose consumption and biomass production by the parent and a mutant strain of <i>Phaffia rhodozyma</i> grown in a 2l fermenter	201
Table 4.8.2.8	Coefficients of correlation calculated for growth (as measured by optical density) and glucose consumption by the parent and a mutant strain of <i>Phaffia rhodozyma</i> grown in a 2l fermenter	201

Table 4.8.2.9	Coefficients of correlation calculated for astaxanthin production and nitrogen consumption by the parent and a mutant strain of <i>Phaffia rhodozyma</i> grown in a 2l fermenter	202
Table 4.8.2.10	Coefficients of correlation calculated for nitrogen consumption and biomass production by the parent and a mutant strain of <i>Phaffia rhodozyma</i> grown in a 2l fermenter	202
Table 4.8.2.11	Coefficients of correlation calculated for growth (as measured by optical density) and nitrogen consumption by the parent and a mutant strain of <i>Phaffia rhodozyma</i> grown in a 2l fermenter	203
Table 4.8.2.12	Coefficients of correlation calculated for glucose consumption and nitrogen consumption by the parent and a mutant strain of <i>Phaffia rhodozyma</i> grown in a 2l fermenter	203
Table 4.8.4.1	Rf values for individual <i>Phaffia rhodozyma</i> carotenoids	209
Table 4.8.4.2	Rf values obtained for the carotenoids in the <i>Phaffia rhodozyma</i> (parent strain) extract	209
Table 4.8.4.3	Rf values obtained for the individual carotenoids in the <i>Phaffia rhodozyma</i> (mutant strain) extract	210

LIST OF FIGURES

TITLE	PAGE
Figure 2.3.1 Configurational Isomers of Astaxanthin	10
Figure 2.4.1 Metabolic Pathways Proposed for Astaxanthin in Atlantic Salmon	12
Figure 2.9.1 Sexual Cycle of <i>Phaffia rhodozyma</i>	28
Figure 2.9.2 Postulated Biosynthetic Pathways for Astaxanthin by <i>Phaffia rhodozyma</i>	31
Figure 2.9.3 Postulated Pathway for Astaxanthin by a mutant strain of <i>Phaffia rhodozyma</i>	32
Figure 2.9.4 Biosynthetic Pathway for Astaxanthin in Crustaceans	33
Figure 2.10.1 Proposed Scheme of Enzymatic Processing of <i>Phaffia rhodozyma</i>	48
Figure 2.10.5 Mutagenesis and Cell Fusion Cycle	52
Figure 3.3.1 General layout of fermentation equipment showing the module power connections	62
Figure 3.3.2 Fermentation Equipment Used	63
Figure 3.3.3 Fitting to the Top Plate of Culture Vessel	64
Figure 3.5.3.1 Basic Dimensions of the Haemocytometer	77
Figure 4.2.1 Percentage extraction of astaxanthin from <i>Phaffia rhodozyma</i> cells after treatment with Novozyme 234	103

Figure 4.2.2	Percentage extraction of astaxanthin from <i>Phaffia rhodozyma</i> cells after treatment with Lyticase	103
Figure 4.2.3	Percentage extraction of astaxanthin from <i>Phaffia rhodozyma</i> cells after treatment with SP 299 Mutanase	104
Figure 4.2.4	Percentage extraction of astaxanthin from <i>Phaffia rhodozyma</i> cells after enzyme treatment for 24 hours using three enzyme preparations	104
Figure 4.5.1.1	Growth curves for <i>Phaffia rhodozyma</i> grown in shake flask culture using various growth media (obtained using viable cell counts)	110
Figure 4.5.1.2	Growth curves for <i>Phaffia rhodozyma</i> grown in shake flask culture using various growth media (obtained using total cell counts)	111
Figure 4.6.2.1	Yields of biomass produced by the parent strain (NCYC 874) of <i>Phaffia rhodozyma</i> grown in shake flask culture using a Yeast Malt Broth and a Mineral Salts Medium	117
Figure 4.6.2.2	Pigment yields produced by the parent strain (NCYC 874) of <i>Phaffia rhodozyma</i> grown in shake flask culture using a Yeast Malt Broth and a Mineral Salts Medium	117
Figure 4.6.2.3	Growth of the parent strain(NCYC 874) of <i>Phaffia rhodozyma</i> grown in shake flask culture using a Yeast Malt Broth and a Mineral Salts Medium	118

Figure 4.6.2.4	Glucose consumption by the parent strain (NCYC 874) of <i>Phaffia rhodozyma</i> grown in shake flask culture using a Yeast Malt Broth and a Mineral Salts Medium	120
Figure 4.6.2.5	Percentage of the carbon source remaining in the growth medium after ten days growth of the parent strain (NCYC 874) of <i>Phaffia rhodozyma</i> in shake flask culture	120
Figure 4.6.2.6	Biomass production and substrate consumption by the parent strain (NCYC 874) of <i>Phaffia rhodozyma</i> grown in shake flask culture using a Yeast Malt Broth	121
Figure 4.6.2.7	Pigment production and substrate consumption by the parent strain (NCYC 874) of <i>Phaffia rhodozyma</i> grown in shake flask culture using a Yeast Malt Broth	121
Figure 4.6.2.8	Growth and substrate consumption by the parent strain (NCYC 874) of <i>Phaffia rhodozyma</i> grown in shake flask culture using a Yeast Malt Broth	122
Figure 4.6.2.9	Biomass production and substrate consumption by the parent strain (NCYC 874) of <i>Phaffia rhodozyma</i> grown in shake flask culture using a Mineral Salts Medium	124
Figure 4.6.2.10	Astaxanthin production and substrate consumption by the parent strain (NCYC 874) of <i>Phaffia rhodozyma</i> grown in shake flask culture using a Mineral Salts Medium	124

Figure 4.6.2.11	Growth and substrate consumption by the parent strain (NCYC 874) of <i>Phaffia rhodozyma</i> grown in shake flask culture using a Mineral Salts Medium	125
Figure 4.6.2.12	Nitrogen consumption by the parent (NCYC 874) and a mutant strain (NRRL-Y-18734) of <i>Phaffia rhodozyma</i> grown in shake flask culture	127
Figure 4.6.2.13	Biomass production and nitrogen consumption by the parent strain (NCYC 874) of <i>Phaffia rhodozyma</i> grown in shake flask culture using a Mineral Salts Medium	128
Figure 4.6.2.14	Pigment production and nitrogen consumption by the parent strain (NCYC 874) of <i>Phaffia rhodozyma</i> grown in shake flask culture using a Mineral Salts Medium	128
Figure 4.6.2.15	Growth and nitrogen consumption by the parent strain (NCYC 874) of <i>Phaffia rhodozyma</i> grown in shake flask culture using a Mineral Salts Medium	129
Figure 4.6.2.16	Percentage of the nitrogen source remaining in the growth medium during ten days growth of the parent strain (NCYC 874) and a mutant strain (NRRL-Y-18734) of <i>Phaffia rhodozyma</i>	130
Figure 4.6.2.17	Yields of biomass produced by the mutant strain (NRRL-Y-18734) of <i>Phaffia rhodozyma</i> grown in shake flask culture using a Yeast Malt Broth and a Mineral Salts Medium	134
Figure 4.6.2.18	Pigment yields produced by the mutant strain (NRRL-Y-18734) of <i>Phaffia rhodozyma</i> grown in shake flask culture using a Yeast Malt Broth and a Mineral Salts Medium	134

Figure 4.6.2.19	Growth of the mutant strain(NRRL-Y-18734) of <i>Phaffia rhodozyma</i> grown in shake flask culture using a Yeast Malt Broth and a Mineral Salts Medium	135
Figure 4.6.2.20	Glucose consumption by the mutant strain (NRRL-Y-18734) of <i>Phaffia rhodozyma</i> grown in shake flask culture using a Yeast Malt Broth and a Mineral Salts Medium	137
Figure 4.6.2.21	Biomass production and substrate consumption by a mutant strain (NRRL-Y-18734) of <i>Phaffia rhodozyma</i> grown in shake flask culture using a Yeast Malt Broth	138
Figure 4.6.2.22	Pigment production and substrate consumption by a mutant strain (NRRL-Y-18734) of <i>Phaffia rhodozyma</i> grown in shake flask culture using a Yeast Malt Broth	138
Figure 4.6.2.23	Growth and substrate consumption by a mutant strain (NRRL-Y-18734) of <i>Phaffia rhodozyma</i> grown in shake flask culture using a Yeast Malt Broth	139
Figure 4.6.2.24	Percentage of the carbon source remaining in the growth medium during ten days growth of the mutant strain (NRRL-Y-18734) of <i>Phaffia rhodozyma</i> in shake flask culture	140
Figure 4.6.2.25	Biomass production and substrate consumption by a mutant strain (NRRL-Y-18734) of <i>Phaffia rhodozyma</i> grown in shake flask culture using a Mineral Salts Medium	142

Figure 4.6.2.26	Astaxanthin production and substrate consumption by a mutant strain (NRRL-Y-18734) of <i>Phaffia rhodozyma</i> grown in shake flask culture using a Mineral Salts Medium	142
Figure 4.6.2.27	Growth and substrate consumption by a mutant strain (NRRL-Y-18734) of <i>Phaffia rhodozyma</i> grown in shake flask culture using a Mineral Salts Medium	143
Figure 4.6.2.28	Biomass production and nitrogen consumption by a mutant strain (NRRL-Y-18734) of <i>Phaffia rhodozyma</i> grown in shake flask culture using a Mineral Salts Medium	145
Figure 4.6.2.29	Astaxanthin production and nitrogen consumption by a mutant strain (NRRL-Y-18734) of <i>Phaffia rhodozyma</i> grown in shake flask culture using a Mineral Salts Medium	145
Figure 4.6.2.30	Growth and nitrogen consumption by a mutant strain (NRRL-Y-18734) of <i>Phaffia rhodozyma</i> grown in shake flask culture using a Mineral Salts Medium	146
Figure 4.7.2.1	Biomass production by <i>Phaffia rhodozyma</i> grown in shake flask culture using glucose at concentrations of 1% and 1.5%	159
Figure 4.7.2.2	Biomass production by <i>Phaffia rhodozyma</i> grown in shake flask culture supplemented after 120 hours with additional glucose at concentrations of 1% and 1.5%	159
Figure 4.7.2.3	Growth of <i>Phaffia rhodozyma</i> in shake flask culture using glucose at concentrations of 1% and 1.5%	160

Figure 4.7.2.4	Growth of <i>Phaffia rhodozyma</i> in shake flask culture supplemented after 120 hours with glucose at concentrations of 1% and 1.5%	160
Figure 4.7.2.5	Astaxanthin yields produced by <i>Phaffia rhodozyma</i> in shake flask culture using glucose at concentrations of 1% and 1.5%	162
Figure 4.7.2.6	Astaxanthin yields produced by <i>Phaffia rhodozyma</i> in shake flask culture supplemented after 120 hours with glucose at concentrations of 1% and 1.5%	162
Figure 4.7.2.7	Glucose consumption by <i>Phaffia rhodozyma</i> grown in shake flask culture using glucose at concentrations of 1% and 1.5%	164
Figure 4.7.2.8	Glucose consumption by <i>Phaffia rhodozyma</i> grown in shake flask culture supplemented after 120 hours with glucose at concentrations of 1% and 1.5%	164
Figure 4.7.2.9	Percentage of glucose remaining in the growth medium during ten days growth of <i>Phaffia rhodozyma</i> in shake flask culture	165
Figure 4.7.2.10	Percentage of glucose remaining in the growth medium during growth of <i>Phaffia rhodozyma</i> in shake flask culture supplemented after 120 hours with 1% and 1.5% glucose	165
Figure 4.7.2.11	Biomass production and substrate consumption by <i>Phaffia rhodozyma</i> grown in shake flask culture supplemented after 120 hours with 1% glucose	167

Figure 4.7.2.12	Biomass production and substrate consumption by <i>Phaffia rhodozyma</i> grown in shake flask culture supplemented after 120 hours with 1.5% glucose	167
Figure 4.7.2.13	Growth and glucose consumption by <i>Phaffia rhodozyma</i> grown in shake flask culture supplemented after 120 hours with 1% glucose	168
Figure 4.7.2.14	Growth and glucose consumption by <i>Phaffia rhodozyma</i> grown in shake flask culture supplemented after 120 hours with 1.5% glucose	168
Figure 4.7.2.15	Astaxanthin production and glucose consumption by <i>Phaffia rhodozyma</i> grown in shake flask culture supplemented after 120 hours with 1 % glucose	169
Figure 4.7.2.16	Astaxanthin production and glucose consumption by <i>Phaffia rhodozyma</i> grown in shake flask culture supplemented after 120 hours with 1.5 % glucose	169
Figure 4.8.2.1	Biomass production by the parent strain (NCYC 874) and a mutant strain (NRRL-Y-18734)of <i>Phaffia rhodozyma</i> grown in batch culture using a 2l fermenter	180
Figure 4.8.2.2	Growth of the parent strain (NCYC 874) and a mutant strain (NRRL-Y-18734)of <i>Phaffia rhodozyma</i> in batch culture using a 2l fermenter	180

Figure 4.8.2.3	Astaxanthin production by the parent strain (NCYC 874) and a mutant strain (NRRL-Y-18734) of <i>Phaffia rhodozyma</i> grown in batch culture using a 2l fermenter	181
Figure 4.8.2.4	Glucose consumption by the parent strain (NCYC 874) and a mutant strain (NRRL-Y-18734) of <i>Phaffia rhodozyma</i> after 180 hours growth in a 2l fermenter	183
Figure 4.8.2.5	Biomass production and glucose consumption by the parent strain (NCYC 874) of <i>Phaffia rhodozyma</i> grown in a 2l fermenter	184
Figure 4.8.2.6	Astaxanthin production and glucose consumption by the parent strain (NCYC 874) of <i>Phaffia rhodozyma</i> grown in a 2l fermenter	184
Figure 4.8.2.7	Growth and substrate consumption by the parent strain (NCYC 874) of <i>Phaffia rhodozyma</i> grown in a 2l fermenter	185
Figure 4.8.2.8	Percentage of glucose remaining in the growth medium during growth of the parent strain (NCYC 874) and a mutant strain (NRRL-Y-18734) of <i>Phaffia rhodozyma</i> in a 2l fermenter	187
Figure 4.8.2.9	Biomass production and glucose consumption by the mutant strain (NRRL-Y-18734) of <i>Phaffia rhodozyma</i> grown in a 2l fermenter	188
Figure 4.8.2.10	Pigment production and glucose consumption by the mutant strain (NRRL-Y-18734) of <i>Phaffia rhodozyma</i> grown in a 2l fermenter	188
Figure 4.8.2.11	Growth and substrate consumption by the mutant strain (NRRL-Y-18734) of <i>Phaffia rhodozyma</i> grown in a 2l fermenter	189

Figure 4.8.2.12	Consumption of nitrogen by the parent strain (NCYC 874) and a mutant strain (NRRL-Y-18734) of <i>Phaffia rhodozyma</i> grown in a 2l fermenter	191
Figure 4.8.2.13	Biomass production and nitrogen consumption by the parent strain (NCYC 874) of <i>Phaffia rhodozyma</i> grown in a 2l fermenter	192
Figure 4.8.2.14	Astaxanthin production and nitrogen consumption by the parent strain (NCYC 874) of <i>Phaffia rhodozyma</i> grown in a 2l fermenter	192
Figure 4.8.2.15	Growth and nitrogen consumption by the parent strain (NCYC 874) of <i>Phaffia rhodozyma</i> grown in a 2l fermenter	193
Figure 4.8.2.16	Percentage nitrogen remaining in the growth medium during growth of the parent strain (NCYC 874) and a mutant strain (NRRL-Y-18734) of <i>Phaffia rhodozyma</i> in a 2l fermenter	195
Figure 4.8.2.17	Biomass production and nitrogen consumption by a mutant strain (NRRL-Y-18734) of <i>Phaffia rhodozyma</i> grown in a 2l fermenter	196
Figure 4.8.2.18	Astaxanthin production and nitrogen consumption by a mutant strain (NRRL-Y-18734) of <i>Phaffia rhodozyma</i> grown in a 2l fermenter	196
Figure 4.8.2.19	Growth and nitrogen consumption by a mutant strain (NRRL-Y-18734) of <i>Phaffia rhodozyma</i> grown in a 2l fermenter	197

Dedication

To the men in my family: My Dad Chris and my brothers Peter, Rory and David, with love and thanks for your support. Especially to my Mother, without whom I would never have made it this far.

Acknowledgements

I would most sincerely like to thank my supervisor Dr. Michael Broaders, for his valuable help throughout this work.

The technicians in the Science Department: John, Martin, Joe, Ken, Karl, Lilly, Mary, Margaret, James, Noel and Mary for their invaluable help, support and sense of humour!

The lecturers of the Science Department especially Dr. John Barrett and Dr. James Brennan, for their help and advice. Also thanks to the heads of the different departments in Science for their support.

To Ray Nuttall at Hoffman La Roche, for his help and advice.

Many thanks to Dr. William D. Prevatt at Phillips Petroleum Company for his invaluable advice and support over the past two years, and for giving of so much of his time and expertise without complaint.

To my colleagues in the research department both past and present, for their advice, support and friendship throughout the duration of this project. Special mentions must go to Anne Marie, Padraig, Cyril, Denise, Margaret and Paula.

Thanks to Eolas for providing the funding for this project, in the form of an Applied Research Grant (ARP / 135 / 90).

Finally, thanks must go to my family for their support during this project. Special thanks to my mother for her encouragement and support.

**'The fascination of what's difficult
Has dried the sap out of my bones,
And rent spontaneous joy and contentment
Out of my heart.'**

**From 'The fascination of what's difficult'
(W.B. Yeats, 1910)**

Abstract

This project concentrated on the use of the commercially available *Phaffia rhodozyma* NCYC 874 as an astaxanthin source. The purpose of this research was to investigate the optimum conditions for a batch fermentation of the yeast. Cell growth and astaxanthin production by the yeast using two different media was investigated, as previous work has highlighted major differences in the growth and efficiency of astaxanthin production in various media. This research was also concerned with the effect of carbon concentration on pigment levels. Consumption of the nitrogen source by the yeast was also investigated with regard to biomass and pigment production. The parent strain (NCYC 874) of *Phaffia rhodozyma* and a mutant strain of the yeast (NRRL-Y-18734), were both cultivated in a laboratory scale 2 litre fermenter to compare biomass and astaxanthin yields and the utilisation of the carbon and nitrogen sources. Three different approaches were used to extract astaxanthin from the yeast cells, mechanical breakage, acid lysis and enzyme treatment.

Phaffia rhodozyma NCYC 874 produced a higher yield of astaxanthin in the Mineral Salts medium than in the Yeast Malt Broth, which is the commercial medium used for culturing the yeast. Higher astaxanthin yields were obtained using a 1% carbon source. The addition of fresh glucose to the growth medium after five days at the two concentrations used resulted in an increase in astaxanthin yields and cell numbers. Production of biomass by the parent strain of the yeast was found to be more closely linked to the consumption of nitrogen, than to consumption of the carbon source. The opposite was observed to be the case regarding the mutant strain of the yeast, with biomass production found to be more closely linked to consumption of the carbon source. Astaxanthin production by the mutant strain of the yeast was found to be more closely linked to nitrogen consumption. This indicated that the mutant strain was more efficient than the parent strain at utilising the nitrogen source to produce pigment. The opposite was observed to be the case regarding the parent strain, with pigment production found to be more closely linked to consumption of the carbon source. The mutant strain of the yeast produced higher yields of biomass and astaxanthin than the parent strain, when grown in both shake flask and fermenter culture. Consumption of the carbon and nitrogen sources by both strains of the yeast followed the same pattern irrespective of the method of culture used.

Chapter One

Introduction

1.0 Introduction.

An important factor affecting consumer acceptance of cultivated salmonids or crustaceans is the colour of their flesh or skin (Calo, P., and Gonzalez, T. 1995). The natural pink colour is due to the carotenoid astaxanthin (3, 3' - dihydroxy - β , β - carotene-4, 4' - dione), a pigment common to some extent in the animal kingdom (e.g. salmon and trout among others), but rarely found in eukaryotic microorganisms (e.g. freshwater and marine microalgae and the yeast *Phaffia rhodozyma*).

Astaxanthin present in salmonid fish must be provided by dietary sources since these fish lack the ability to biosynthesise astaxanthin. When raised in aquaculture salmonids must be fed diets consisting of a source of this carotenoid compound, in order to produce their normal pigmentation (Sanderson, G.W., and Setsuko, O.J. 1994) . Therefore, the industrial importance of *Phaffia rhodozyma* derives from its ability to synthesise one of the most important nutrients in aquaculture. The cultivation of fish and crustaceans has become an important business, and marine fish farming currently provides 10 to 15% of the seafood consumed worldwide. The production of farmed salmon and trout has increased dramatically in the last decade. Salmon and trout aquaculture has increased from 5,000-10,000 metric tonnes in the mid 1970's, to 750,000 metric tonnes in 1994. By the year 2000 it is expected that salmon farming will dominate the markets for Atlantic, coho and chinook salmon. In 1990 fish and crustacean farming was estimated to be a 20 billion dollar industry, and is projected to increase to over 40 billion dollars by the year 2000 (Johnson, E.A., and Schroeder, W. 1995).

In Asia, chemically synthesised astaxanthin comprises an estimated \$22 million market, while until now in the U.S. aquaculturists have relied on a more expensive source - shrimp by-product meal. However, on April 14, 1995, the American Food and Drugs Administration approved the use of astaxanthin in fish feed, but feeding whole *Phaffia rhodozyma* as a source of the pigment has yet to be approved (Leathers, T., and Hardy, R. 1995). Currently, the practice is for chemically synthesised astaxanthin and canthaxanthin to be added to salmonid feeds as pigmenters, but there is huge interest within the aquaculture industry in using natural sources of astaxanthin.

The principal biological sources of astaxanthin being considered are crustacea and crustacean extracts, the green microalga *Haematococcus pluvialis*, the yeast *Rhodotorula rubra*, and the red yeast *Phaffia rhodozyma*. All of these natural sources will be considered in more detail in Chapter Two (Literature Review). Each of these natural sources has its limitations and they cannot currently compete with the synthetic products available (Johnson, E.A., and An, G.H. 1991). Crustacean meals have low levels of astaxanthin and high levels of moisture, ash and chitin. The algae *Haematococcus pluvialis* has a relatively high concentration of astaxanthin, but industrial application is limited by the lengthy autotrophic cultivation in open freshwater ponds, and the contamination experienced during the cultivation of the organism. The yeast *Rhodotorula rubra* has desirable properties as a biological source of the pigment (Ravinder, P.K., Sangha, T.P., and Martin, A. 1995). However, research carried out with *Rhodotorula* is new, and early indications are that there are several problems that will have to be overcome before this yeast will be seen as a serious alternative source of astaxanthin. These include an extremely thick cell wall, which has proved very resistant to various extraction techniques including mechanical and enzymatic breakage. The biological mechanism by which astaxanthin is produced by the yeast has also yet to be understood. Therefore, at present, *Phaffia rhodozyma* remains the most attractive and viable alternative to the chemically synthesised versions of the pigment.

This red pigmented yeast was isolated in the sixties from the exudates of different trees, and named after Professor Herman J. Phaff. The yeast has been included since then in the deuteromycetous group, but is considered to most likely have a basidiomycetous origin due to its cell wall composition. This yeast is strikingly different from other basidiomycetous yeasts such as *Rhodotorula*, in that it synthesises and accumulates the carotenoid astaxanthin as the principal carotenoidic pigment, an end product of a putative four step bioconversion from beta-carotene (Calo *et al.* 1995).

Previous studies have shown that *Phaffia rhodozyma* can be produced at a very low cost using various substrates as the raw material (Calo *et al.* 1995). Various extraction processes have been employed to release the pigment from the cells, including mechanical and enzymatic breakage. Enzymatic breakage of the cells has been shown to be very effective, releasing over 80% of the cellular pigment (Prevatt, W.D. 1992). Mutants of the yeast have been

developed that can produce over 5000 $\mu\text{g/g}$ yeast after five days growth in shake flasks. Most *Phaffia rhodozyma* strains do not currently exhibit the sexual state. However, reports on the isolation of auxotrophic mutants, plus the discovery on sexual activity (Calo *et al.* 1995), opens up new ways of trying to initiate a genetic approach to the problem of astaxanthin synthesis and eventual cloning of the genes involved. This all combines to make *Phaffia rhodozyma* at present, the only viable 'natural' alternative to the chemically synthesised versions of astaxanthin currently in widespread use.

Economic considerations mean that any astaxanthin produced from a biological source will have to compete with the synthetic product. At present, the synthetic products are much cheaper to purchase than the natural alternatives. However, a market for the 'natural' source of the pigment can still exist, in the new environmentally aware age.

Chapter Two

Literature Review

2.0 Literature Review.

2.1 Introduction

The cultivation of fish and crustaceans has become a very important industry, and at present, marine fish farming currently provides 10 - 15% of the seafood consumed worldwide (Johnson, E.A., and Schroeder, M. 1995). The aquaculture industry in general has grown dramatically over the past decade, with salmon and trout cultivation increasing from 5,000 - 10,000 metric tonnes in the 1970's to 600,000 metric tonnes in 1991 (FAO Fisheries Circular 1991). By the year 2000 fish and crustacean farming is expected to be worth in excess of 40 billion dollars (Rosenberry, B. 1993). With many of the valuable fishing waters in the world over exploited, and with the current limits on fishing quotas imposed by the European Union (Rumsey, G.L. 1988), the fish farming industry is expected to expand even further over the next few years, with farmed salmon dominating the markets by the year 2000 (Johnson *et al.* 1995).

The success of the aquaculture industry, as with other markets, is dependant on consumer approval and support. Optimal flesh colour is one of the most important factors that determines the market value of farmed salmon and trout (Higgs, D., Donaldson, E., Dosanjh, B., Chambers, E.A., Shamaila, M., Skura, B., and Furukawa, T. 1995). Pigmentation of salmonids is dietary in nature, and is caused by the presence of the carotenoid pigment astaxanthin. Salmon and trout in the wild obtain carotenoid pigments by ingesting prey such as euphausiids, shrimp and copepods, and the predominant carotenoid found in these crustaceans is astaxanthin. As salmonids, crustaceans and other animals cannot synthesise astaxanthin, or other carotenoids, the pigments must be supplied in the diet (Higgs *et al.* 1995). Present salmon and trout diet formulations are supplemented with either synthetic astaxanthin (Carophyll Pink) or synthetic canthaxanthin (Carophyll Red). Both of these compounds are manufactured by Hoffman la Roche, and their addition into salmonid diets accounts for 10 - 15% of the diet cost. In British Columbia alone this represents an annual expenditure of over 6 million dollars per annum (Higgs *et al.* 1995).

As well as the high costs involved with the usage of these synthetic formulations, there has been an increasing trend by the consumer towards using

natural sources of feed nutrients where possible. There has also been an increasing wariness on the part of the consumer to the introduction of synthetic chemicals to the food chain, even though the chemicals may be identical to naturally occurring compounds (Johnson *et al.* 1991). Although astaxanthin has been shown to be a more efficient pigmenter than canthaxanthin (Little, A.C., Martinsen, C., and Scurman, L. 1979), canthaxanthin is currently the preferred pigmenter source. This is because salmon that have been pigmented with canthaxanthin can be exported to the United States, but the entry of salmon that have been fed diets supplemented with astaxanthin is prohibited (Higgs *et al.* 1995). It was only on April 11th 1995 that the American Food and Drugs Administration approved the use of astaxanthin in fish feed (Leathers, T.D., and Hardy, R. 1995). Until now, the only 'natural' source of astaxanthin that is in use, is the very expensive shrimp by-product meal relied upon by U.S. aquaculturists. This costs approximately 5,000 to 10,000 dollars per kilogram. All of these factors have created the need for a 'natural' source of astaxanthin which is cost effective and less source dependant. Briefly, the most promising alternative sources of astaxanthin are crustacea (primarily the shrimp *Pandalus borealis*, and the krill *Euphausia superba* and *E. pacifica*), microalgae (*Haematococcus pluvialis*), the yeast *Phaffia rhodozyma*, and *Rhodotorula rubra*.

Several researchers have evaluated crustaceae and their derivatives as pigment sources (Torrissen, O.J., Hardy, R., and Shearer, K.D. 1989). In Norway, shrimp (*Pandalus borealis*) wastes have been used traditionally as natural pigment sources for salmon and trout. Carotenoid levels in most crustacean preparation however, are quite low (0 to 200 mg/kg) (Torrissen *et al.* 1989), and in order to obtain satisfactory pigmentation, the addition of 10 - 25% by weight of the chitinous extract to the diet is needed. Crustacean wastes also have high levels of moisture, ash and chitin, and low levels of protein, which limits their effectiveness (Lambertsen, G., and Braekkan, O.R., 1971). Developments in the extraction and concentration of the carotenoids, could improve the feasibility of crustacean wastes for pigmentation. Torrissen *et al.* (1989) concluded that shrimp meal has limited potential as an astaxanthin source for salmonids.

Many different plants and algae contain carotenoids. Certain green algae in the subphylum *Chlorophyceae* possess astaxanthin as their principal carotenoid (Lwoff, M., and Lwoff, A. 1930). Depending on the method and control of

culture, very high levels of astaxanthin accumulate in *Haemotococcus pluvialis* (0.5% to 2% astaxanthin on a dry weight basis), (Droop, M.R. 1955), and (Spencer, K.G. 1989). Most astaxanthin (87%) occurs esterified, which may affect its deposition and metabolism in some animals. Low deposition of astaxanthin by feeding algae to salmon was obtained by Kvalheim and Knutson (1985), and it was suggested that this was due to astaxanthin being present principally as esters. However, poor deposition caused solely by esterification was not confirmed by others (Torrissen *et al.* 1989). Another possible limiting factor is the availability of carotenoids from the algal biomass. Highly pigmented algae occur in an encysted form surrounded by a thick cell wall, and this barrier could also impede the absorption of pigments.

The use of yeast preparations in providing pigmentation has been treated with special interest due to their inherent usefulness in animal feeds. Brewer's and Baker's yeasts are recommended for use in commercially prepared feeds for pen reared fish, due to the high protein and vitamin levels present. During the 1970's, a yeast was classified which had high levels of astaxanthin (from 50 to 800 µg/g), and was named *Phaffia rhodozyma* (Miller, M.W., Yoneyama, M., and Soneda, M. 1976), in recognition of the contribution to yeast taxonomy made by the botanist who discovered it, Herman J. Phaff. The colonies produced by the yeast vary in colour from orange to red, and it has been observed that glucose, maltose, raffinose and sucrose are fermented by the organism (Phaff, H.J., Miller, M.W., Yoneyama, M., and Soneda, M. 1972). Nine strains of the yeast were isolated from the exudates of deciduous trees (Phaff *et al.* 1972). This project focuses on the use of *Phaffia rhodozyma* as an astaxanthin source. Since 1976, there has been a vast amount of work published in this field. The effectiveness of *Phaffia rhodozyma* as a pigmenter was documented in studies by Johnson E.A., Conklin, D.E., and Lewis, M.J. (1977). Subsequent investigations have concentrated on the effect that different parameters have on growth and pigmentation (Johnson, E.A., and Lewis, M.J. 1979), the development of strains that have a higher astaxanthin content (An, G.H., Schumann D.B., and Johnson, E.A. 1989), the development of cell disruption methods for improved nutritional availability (Johnson, E.A., Schreiber, D., Ho, P.K., Hall, W.T., Yang, H.H., and Geldiay-Tuncer, B. 1991), and more reliable analysis of the desired pigments (Johnson, E.A., Villa, T.G., Lewis, M.J., and Phaff, H.J. 1978). All of this work will be reviewed in greater detail in a later section of this chapter.

2.2 Carotenoid Pigmentation of Salmonids

Distinctive red colour is of prime importance to consumer acceptance of farmed salmon and trout (Ostrander, J., and Martinsen, C. 1976), and Scurman, L., and Little, A. 1979). Salmonids depend on the absorption and deposition of appropriate oxycarotenoid pigments to obtain red colouration of flesh and other tissues (Gentles, A., and Haard, N.F. 1991). As far back as the early 1900's, there was an interest in the colouration of salmon and trout (Prince, E. 1916). Astacene was reported in the early 1900's as the principle carotenoid in salmonids. Later it was found to be a degradation product naturally occurring in salmon (Steven, D.M. 1948). Confirmation of this was published in 1973 (Khare, A., Moss, G.P., Weedon, B.C.L., and Matthews, A.D. 1973).

In nature, ingestion of zooplankton leads to fish pigmentation (Torrissen, O.J., Hardy, R.W., and Shearer, K.D. 1989) as salmonids cannot biosynthesise carotenoidic compounds like astaxanthin and canthaxanthin. The astaxanthin content of salmon varies a great deal depending on species, sex, maturity, nutrition and health. For example, mature Atlantic salmon contains 3 to 8 ppm while sock eye salmon can have contents as high as 37 ppm, imparting a vivid pigmentation (Torrissen *et al.* 1989).

Astaxanthin occurs mainly in the free form (unesterified) in salmon flesh, and esterified in the skin and ovaries. The uptake of astaxanthin and other carotenoids from the feed depends on the chemical structure of the carotenoid: the proportion of cis - isomers, esterification, and the association of the carotenoid with fats or proteins. Carotenoids are generally absorbed with poor efficiency by animals, and little is known of the uptake mechanism and the means by which uptake could be enhanced (Storebakken, T. 1988). Free astaxanthin was reported to be more efficiently deposited in fish muscle than esterified astaxanthin and canthaxanthin, although this has been disputed in feeding trials using krill astaxanthin diester, and synthetic free astaxanthin (Mori, T., Makabe, K., Yamaguchi, K., Konosu, S., and Atai, T. (1989)). It is possible that krill astaxanthin was more efficiently deposited in salmonids than the synthetic, due to association with lipids or other compounds promoting absorption, but further studies are needed to understand the mechanisms of uptake, metabolism, and deposition (Katsuyama, M., Komori, T., and Matsuno, T. 1987).

Since astaxanthin has two identical chiral centres, it exists as three configurational isomers in nature: (3S, 3'S), (3S, 3'R), and (3R,3'R). Each configurational isomer appears to be deposited equally well in salmonids. When racemic astaxanthin was fed to salmon and trout, the proportion of isomers detected in the flesh was identical to that present in the feed (Foss, P., Storebakken, T., Austreng, E., and Liaan-Jensen, S. 1987). Rainbow trout appeared to preferentially hydrolyse the R configurational isomers of the palmitate esters, suggesting that the esterases have a stereochemical preference for the R configuration. It was observed that the (3R, 3'R) astaxanthin diester was deposited in the flesh of the rainbow trout twice as efficiently as the (3S, 3'S) diesters, but further confirmation would be needed (Katsuyama *et al.* 1987).

2.3 Carotenoids - in General

There are a vast number of pigments in nature providing a varied and rich array of colours. Without doubt, the carotenoids are the most widely distributed class of pigments in nature, and have essential biological functions in animals. The actual number of carotenoids that occur naturally is unknown, but more than 600 carotenoids are known to exist in the natural kingdom to date (Goodwin, T.W. 1992). Carotenoids also have important metabolic functions in animals and man, including the conversion of vitamin A, enhancement of the immune response, and protection against diseases such as cancer by scavenging of oxygen radicals (Bendich A., and Olson, J.A. 1989). Most animal carotenoids can be traced back along the food chain, and any carotenoids that are characteristic of animals are formed by metabolic transformations of the food carotenoids (Goodwin, T.W. 1992). Despite their wide distribution, carotenoids cannot be synthesised by animals, only by higher plants and protists (Goodwin, T.W. 1992).

Carotenoids are a class of hydrocarbons (carotenes), and their oxygenated derivatives (xanthophylls). They are lipid soluble, chemically unsaturated, nitrogen - free compounds of high molecular weight. They occur in small amounts as mixtures of related compounds. Their basic structure reflects their mode of biosynthesis. The two main classes of carotenoids; xanthophylls and carotenes, differ due to the fact that oxygenation occurs in the xanthophylls, while only carbon and hydrogen are involved (chemical formula $C_{40}H_{56}$) with the carotenes. The molecular configuration responsible for colour

manifestation in carotenoid compounds, is a conjugated double bond system where the unsaturated linkages occur between alternate pairs of carbon atoms in a long, multiply branched chain (Goodwin, T.W. 1972). Hydrogenation, dehydration, cyclization and oxidation of carotenoids occurs easily, making purification and analysis of individual carotenoids from natural sources extremely difficult (Torrossen *et al.* 1989).

Astaxanthin (3, 3'-dihydroxy- β , β -carotene-4, 4'-dione), is probably the most abundant carotenoid in nature, and is a xanthophyll with the molecular formula $C_{40}H_{55}O_4$, and has a molecular weight of 596.86 (Straub, O. 1976). It consists of an ionone - like substance with a cyclohexenyl ring at each end of an 18 carbon chain, with an -OH group at C-3 and C-3', and an =O group at C-4 and C-4'. Isolated crystalline astaxanthin has the appearance of a fine, dark violet brown powder, with a melting point of 224°C. It is insoluble in aqueous solutions and most organic solvents, but can be dissolved at room temperature in various nonpolar solvents such as acetone (~ 0.2 g/l), and chloroform (~ 10g/l) (Straub *et al.* 1976). Astaxanthin occurs as a mixture of configurational isomers in animals (Johnson *et al.* 1991). Astaxanthin can exist in four configurations; including the identical enantiomers (3S, 3'S; and 3R, 3'R), and meso forms (3R,3'S; and 3'R,3S) (Figure 2:3:1). The 3S,3'S configuration can be found in most of the natural sources of astaxanthin (aquatic and algal), including the lobster *Homarus gammarus*, and the alga *Haemotococcus phuvialis* (Andrewes, A.G., and Starr, M.P. 1976). Oddly, the astaxanthin isolated from the krill *Euphausia superba* (Maoka, T., Katsuyama, M., Kanako, N., and Matsuno, T. 1985), and the red yeast *Phaffia rhodozyma* (Andrewes *et al.* 1976) had the 3R,3'R configuration; which is the opposite to that of astaxanthin from other natural sources. This indicated for the first time that naturally occurring carotenoids were biosynthesised in different optical forms (Andrewes *et al.* 1976). All of the meso enantiomeric configurational isomers of astaxanthin have been detected in wild salmon (Scheidt, T., Leuenberger, F.J., and Vecchi, M. 1981), and it is currently the belief (Johnson *et al.* 1991), that the occurrence of specific isomers in salmon, reflects the source of the food in nature and is therefore of no relevance biologically to the fish (Scheidt, K., Foss, T., Storebakken, T., and Liaan-Jensen, S. 1989). Carotenoids in fish mainly occur dissolved in fatty areas in gonads, eggs, skin and liver. Free astaxanthin is deposited in fish muscle, and is associated with specific lipoprotein storage units (Crozier, G.F. 1974), and while xanthophylls

in the skin are deposited as esters of higher fatty acids, only free astaxanthin is found in the flesh (Scheidt *et al.* 1981).

Figure 2.3.1 Configurational Isomers of Astaxanthin

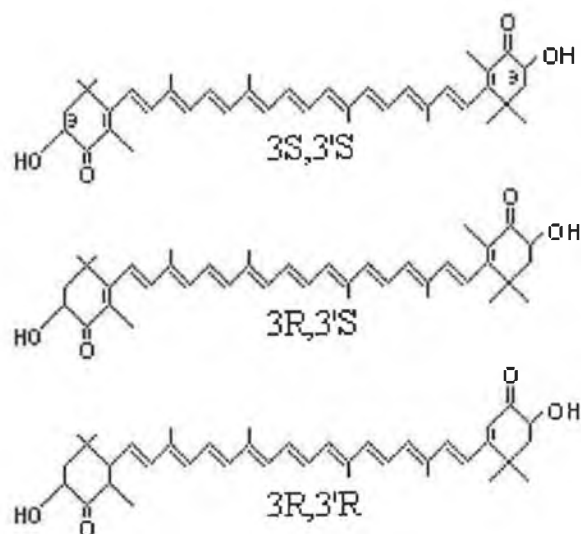

(Storebakken *et al.* 1987)

2.4 Astaxanthin: Function and Metabolism in Salmonids

Previous studies carrying out chromatographic tests for carotenoids have indicated that young salmon eggs only contain astaxanthin, and that this is present only in the free, or unesterified state (Craik, J.C.A, and Harvey, S.M. 1986). Earlier studies had shown the metabolism of astxanthin and fat to be independant (Glover, M., Morton, R.A., and Rosen, D.G. 1952). However, more recent studies have shown that astaxanthin in the muscle of the salmon has been proven to involve lipoprotein storage units, and high levels of polyunsaturated fats in the diet have been proven to aid carotenoid deposition and absorption (Sinnot, R. 1988).

There is very little known about the uptake mechanisms of the pigment, or how the rate of absorption of the pigment into the flesh can be enhanced (Johnson *et al.* 1991). However, recent studies have shown that the deposition of astaxanthin is increased by approximately 0.018 mg/kg, for every percentage increase in dietary lipid (Torrissen O.J. 1984). This finding could indicate that

the protein or lipid association allows better protection to the carotenoids from digestive tract enzymes, or that they both allow more efficient transfer of the carotenoid pigment across the intestinal barrier. The retention of pigments in salmonids can vary, depending on several factors including;

- the metabolism and rate of excretion;
- the efficiency of absorption from the digestive tract;
- the deposition mechanisms in the various tissues;
- and the transport capacity.

Many factors can also affect the rate of deposition of the pigment in fish flesh, including the size of the fish and the how fast the fish grows. It is accepted that differences in flesh pigmentation between weight classes can be found to vary by up to 35% (Torrissen O.J., and Naedval, G. 1988). In faster growing fish there is decreased pigment deposition, and this is most likely due to two interacting factors; with increasing growth, there is an increased ingestion of food, and hence of the feed pigment. The increased flesh mass (due to fast growth) needs extra pigment. This would suggest a limit to the deposition rate, compared with the growth rate (Torrissen *et al.* 1989).

The 3,4 oxygenated xanthophylls are absorbed preferentially by the fish, depositing them in the free form in the flesh. In the skin, esters are found (Goodwin, T.W. 1951). It has been reported that free astaxanthin is more efficiently deposited in fish muscle than the esterified form, although this has been disputed (Storebakken *et al.* 1987). All the configurational isomers of astaxanthin are deposited equally well in salmonids, with the proportion of isomers in the flesh equal to that present in the feed (Torrissen *et al.* 1989), and (Foss, P., Storebakken, T., Scheidt, K., Liaaen-Jensen, S., Austreng, E., and Streiff, K. 1984). During the reductive metabolism of astaxanthin to zeaxanthin, epimerization from 3S to 3R isomer was reported in the skin of some astaxanthin pigmented fish (Storebakken, T., Foss, P., Austreng, E., and Liaaen-Jensen, S. 1985). This is thought to be specific to the Atlantic salmon, although idoxanthin is found in juvenile salmon which may be due to the stress brought on by experimental conditions (Bernhard, K. 1991). The proposed

metabolic pathways for astaxanthin in Atlantic salmon is shown in Figure 2.4.1 (Scheidt, K.F., Leuenberger, F.J., Vecchi, M., and Glinz, E. 1985).

Certain species of salmon, like the chinook salmon, show very poor pigmentation (March, B.E., Hajen, W.E., Deacon, G., Macmillan, C., and Walsh, M.G. 1990). Even in the same species genetic differences can be seen. The stage of sexual maturation in male and female fish, also has a significant effect on the level of carotenoid pigment in the flesh. Levels of pigment are usually very high in immature fish. The level of pigment is also known to be higher in maturing females than in males (Asknes, A., Gjerde, B., and Roald, S.O. 1986).

Figure 2.4.1 Metabolic Pathways Proposed for Astaxanthin in Atlantic Salmon

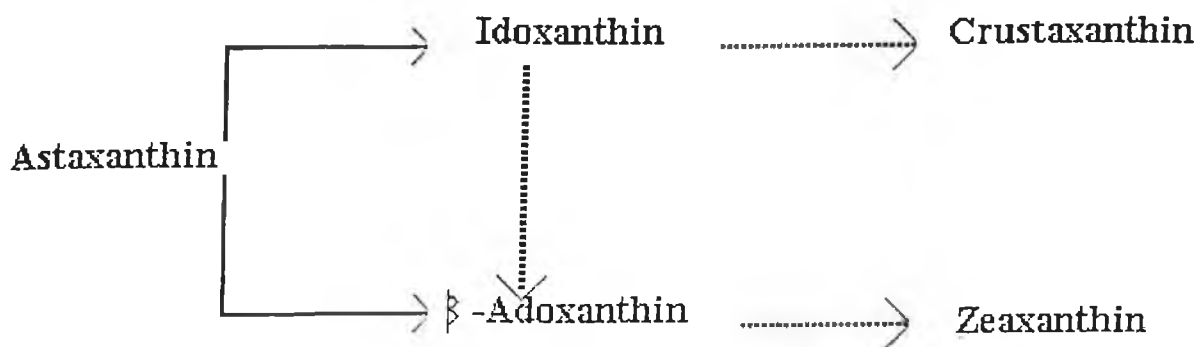

(Scheidt, K.F., Leuenberger, F.J., Vecchi, M., and Glinz, E. 1985)

A great deal of research has been carried out concerning the possible metabolic functions of carotenoids in salmonid fish. Carotenoid content has been linked with egg quality, fertilisation, hatching and survival (Tacon, A.G.J. 1981). Craik (1985) observed that 1 to 3 mg of carotenoids per gram of salmonid eggs, was associated with hatching percentages of above 60%, whereas lower carotenoid levels produced hatching percentages of below 50%. Craik concluded that no simple linear relationship exists between egg pigment content, and quality. Hardy, R.W., and Stickney, R.R. (1992), conducted a study in which they found that under certain conditions of culture, offspring of Atlantic salmon that were fed diets without astaxanthin in their 'first' year, suffered more than 85% mortality, whereas cohorts receiving feed containing astxanthin survived and flourished. Watanbe, T., Itoh, A., Murakami, A.,

Tsukashima, Y., Kitajima, C., and Fujita, S. (1984), have reported that dietary astaxanthin significantly increased the number of normal larvae produced from red sea bream broodstock, from 51.6% (eggs from broodstock that received no dietary carotenoids), to 91.2% (eggs from broodstock that received dietary astaxanthin). All of this information suggests that the addition of astaxanthin into the diet of fish at the start of the production cycle of various species of fish, significantly increased the survival rate, and quality of the eggs and flesh of the various fish species.

It was presumed that astaxanthin provided protection against the deleterious effects of the low available oxygen conditions that often occur in intensive shrimp farming operations. This conclusion is borne out by the results of studies carried out using farmed tiger shrimp (*Penaeus monodon*). Low levels of carotenoids in this species is responsible for "blue shrimp" disease (poor survival rates), which is a common problem in intensive shrimp operations (Howell, B.K., and Matthews, A. 1991). It was presumed that astaxanthin provided protection against the low oxygen conditions that led to the disease. In a separate study using kuruma prawns (*Penaeus japonicus*), Chien, Y.M., and Jeng, S.C. (1992), found that those that were fed astaxanthin had a higher survival rate, than those prawns fed on similar amounts of dietary β -carotene, or algal meal. The researchers concluded that dietary astaxanthin was effective in increasing the survival rate of the shrimps.

It is thought that the carotenoid pigments have a function in reproduction, since there is a change in the distribution of carotenoids during the maturation of both male and female fish. It has been found that the levels of astaxanthin in the ovaries, skin, flesh and plasma are influenced by the time and stage of sexual maturation (Torrissen, K.R., and Torrissen, O.J. 1985). Studies have shown that maturing fish only retain about 40% of the astaxanthin level of immature fish. It has also been shown that the availability of dietary astaxanthin and the level of astaxanthin in the flesh, affects the rate of transfer of astaxanthin from the flesh, to the ovaries (Torrissen *et al.* 1985). Astaxanthin has also been thought to improve sperm motility (Skrede, G., and Storebakken, T. 1986). As the fish matures, its skin changes from a silver to a brownish colour. This occurs prior to a loss in colour from the muscle, suggesting that dietary astaxanthin is used for the pigmentation of the skin (Storebakken, T., Foss, P., Scheidt, J.K., Austreng, E., Liaaen-Jensen, S., and Manz, U. 1987). The level of carotenoids in the plasma is influenced primarily by the

absorbance of carotenoids from the diet. Although astaxanthin has been thought to have a specific function in reproduction, as stated previously, the pigment has been reported to have a growth promoting effect, if supplemented in the start feed diet of Atlantic salmon fry (Johnson *et al.* 1977). This could be due to the carotenoids acting as biological antioxidants. This growth promoting effect could also be due to different behaviour associated with skin colour.

Astaxanthin has also found to have a biological function as a Vitamin A precursor (Katasuyama, M., and Matsuno, T. 1988) have reported that di - hydroxy - carotenoids, such as astxanthin, zeaxanthin, lutein, and tunaxanthin were bioconverted into Vitamin A² alcohol in *Tilapia nilotica*. Studies with Vitamin A depleted rainbow trout were conducted (Scheidt *et al.* 1985), which reported that there was evidence to suggest that higher concentrations of astaxanthin led to greater resistance to fungal and bacterial diseases, due to the fact that Vitamin A plays a vital role in strengthening the cell membrane. Recent studies have looked at the effect of dietary astaxanthin on the histology of the liver of *Oreochromis niloticus* and *Colisa labiosa*, two species of fish whose pigmentation is related directly to dietary carotenoid levels (Segner, H., Arend, P., von Poeppinghausen, K., and Schmidt, H. 1989). This study showed that increasing astaxanthin in the diet, from 0 to 132 mg/kg (diet) showed an improvement in the histology of the liver structure. The researchers concluded that astaxanthin has a positive nutritional function in the intermediary metabolism of these fish.

Astaxanthin has been shown to inhibit oxidative injury (Kurashige, M., Okimasu, E., Inoue, M., and Utsumi, K. 1990), and (Miki, W. 1991), and has also been shown to be more efficient than β -carotene and zeaxanthin in retarding the hydroperoxidation of methyl linoleate (Terao, O. 1989). Palozza, P., and Krinsky, L. (1992), carried out a study using rat liver microsomes, and their results suggested that astaxanthin protected biological membranes by an antioxidant mechanism. The mechanisms by which this occurs however have yet to be fully understood and require further research. All of the research carried out to date, suggests that adequate levels of astaxanthin in the flesh of salmonid fish may offer some protection against the oxidation of bodily lipids.

2.5 Use of Synthetic Pigments - Current Pigmenting Practices

When including astaxanthin into salmonid feed for pigmenting purposes, it is of vital importance that the pigment is included at a level that produces good pigmentation, and is cost effective. Pigment is not added to the diet of salmon until after the fry stage, as they do not store the pigment in their flesh at this point. Salmon weigh at least 100g or over, before pigment is stored in the flesh (Jackson, A. 1988), and (Mills, D. 1989).

The primary purpose of the addition of carotenoid supplements to salmonid feeds, is to achieve acceptable pigmentation of the fish, in order to produce a more attractive, and therefore more marketable commodity. Many studies have been carried out in order to determine the correct levels of pigment that must be added to the feed of pen reared fish, in order to obtain optimum absorption of the pigment by the fish, leading to good colouration.

The regime of pigmentation is determined by two main biological factors; the absorption and deposition of carotenoids ingested by the fish, and the metabolic loss of deposited carotenoids (Torrissen, O.J. 1985). There are two schools of thought on the influence of dietary carotenoids, on the level of carotenoid in the flesh of the salmonid (Torrissen *et al.* 1989). The first theory assumes that there is a linear increase in carotenoid concentration as the weight of the fish increases, which implies that there is an increase in retention efficiency. According to this theory, pigmentation begins quite late in the production cycle, and this shorter pigmentation time can be compensated for by using a higher level of carotenoids in the feed. This is recommended by some sources (Simpson, K.L., Katayama, T., and Chichester, C.O. 1981), who recommend a dietary pigment level of up to 20 mg of astaxanthin per 100g of feed, for up to four months. Since it has been found that using higher pigment levels in the feed does not lead to more efficient absorption, and that using higher levels of astaxanthin can also lead to patchy pigmentation, this strategy is not widely used (Sinnot, R. 1988) and (Torrissen, O.J. 1985).

The second theory on the subject makes the assumption that pigment retention by the fish remains constant during the life cycle. It is suggested therefore, that pigmentation should be started early in the production cycle, with the final level of pigment in the fish being determined by the level of pigment in the

feed. It has been found to be more efficient to pigment salmonids in this manner (Torrissen, O.J. 1985), and (Sinnot, R. 1988).

It is thought that the level of stress to which the fish may be subjected, directly affects the deposition of pigments in the fish. Therefore, fish in a stressed condition deposit lower levels of pigment than fish who are kept in a non-stressed environment (Spinelli, J., and Mahnken, C. 1978). The rate of carotenoid deposition has been shown to be primarily related to the weight of the fish, and the carotenoid content of the diet (Hildingstam, J. 1976).

The decrease in carotenoid deposition with increasing carotenoid levels, has led to the view that other dietary components should be re-examined. The most common method of pigmentation of pen-reared salmonids, is the addition of synthetic pigments to the pelleted fish feed. Hoffmann La Roche over many years, have developed advanced syntheses for various carotenoids. Hoffmann La Roche produce two synthetic carotenoid pigments which are commonly added to pen-reared salmonid feeds. Canthaxanthin in a synthetic form was produced by the company in 1964, and is marketed under the brand name of "Roxanthin", or "Carophyll Red" (Isler, O. 1971). Roche also accomplished the synthesis of trans-astaxanthin, and this product is marketed as "Carophyll Pink". There are many methods of synthesis for astaxanthin, and these have been published mainly Roche patents (Mayer, H.J., and Miller, R.K. 1981), (Broger, E.A., Cramer, Y., Leuenberger, H.G.W., Widmer, E., and Zell, R. 1981), and (Bernhard, K., Muller, R.K., and Spruijtenberg, R. 1986). The commercially synthesised astaxanthin is a fine, dark violet powder containing 8% astaxanthin, and is stabilised in beadlet form by various ingredients including; gelatin, sucrose, corn starch, modified food starch, ascorbyl palmitate, and ethoxquin. The cis-astaxanthin content is not to exceed 2%. The synthetic product sells for approximately \$2,000 to \$2,500 / kg (dry weight basis). The stabilisation process is necessary to protect the carotenoid particles, to allow homogenous distribution in the feed and to aid the resorption of the pigment by the organism. The Carophyll pink product contains the astaxanthin in a racemic mixture, with the individual isomers present in the ration (3S, 3'S : 3R, 3'R : meso) = (1:1:2) (Nuttall, R. 1994). The addition of the synthetic pigments to the salmonid diets in a stabilised pellet, allows the carotenoids to be incorporated effectively into any diet, at controllable levels, without any major effect on the dietary quality (Torrissen, O.J. 1985).

The presence of astaxanthin in wild fish has long been accepted (Knaemitsu, T., and Aoe, H. 1958). Canthaxanthin was used initially to pigment salmon for canning (Herbert, V. 1991). This process caused the colour of the salmon to change to a more intense orange red colour. Synthetic canthaxanthin was widely used and on the market for several years, before the availability of the synthetic astaxanthin. Feeding studies have showed that astaxanthin is superior as a pigments (Torrissen *et al.* 1989). In tests, canthaxanthin supplemented feed has been compared with feed containing all of the individual isomers of astaxanthin, and containing the synthetic preparations mixture of all three. Each of the astaxanthin preparations performed equally well, while the canthaxanthin preparation only caused half the pigmentation achieved by the others (Skrede, G., and Storebakken, T. 1986). Even when canthaxanthin was used in the feeds at a higher concentration than astaxanthin, astaxanthin still gave higher deposition and absorption levels (Torrissen, O.J. 1989). When astaxanthin and canthaxanthin are combined in the diet, higher levels of pigmentation were observed, than was observed when astaxanthin and canthaxanthin were used individually (Torrissen, O.J. 1989).

Canthaxanthin is no longer used as a pigments on such a wide scale, mainly due to the concerns expressed about its safety, but also because it is less effective as a pigments than astaxanthin. It is banned in some countries including: Korea, Libya, Russia, and some Eastern European countries, although the American Food and Drugs Administration (F.D.A.) has allowed its use as a pigments for many years (Bernhard, K. 1991).

Canthaxanthin has been used as an oral tanning agent, as the pigment is retained in the subcutaneous fat (Sinnot, R. 1988). Canthaxanthin has been implicated (by association only) in a fatal case of aplastic anaemia, although there is no definite evidence of the link (Bluhm, R., Branch, R., Johnston, P., and Stein, R. 1990) Toxicological tests have been carried out on canthaxanthin and astaxanthin, and no mutagenic, teratogenic, toxic or embryotoxic effects have been found (Bernhard, K. 1991). Following the usage of astaxanthin as a carotenoid pigments, no adverse effects have been discovered (Herbert, V. 1991).

Synthetic astaxanthin, rather than than synthetic canthaxanthin is the predominant pigments used at present. There is a market for 'natural' carotenoids, even when the synthetic alternative may cost a little less. It is now

the task to find a suitable organism to produce astaxanthin, using a process that has an industrial application and is both effective and economic.

2.6 Crustacean Wastes as Astaxanthin Sources

Over recent years there has been an increasing interest by the seafood industry, in the usage of the non - edible parts of crustaceans, which are usually discarded in vast quantities (Meyers, S.P., and Rutledge, J.E. 1971). Uses are now being found for these wastes, and these include the decalcification of the wastes allowing the protein present to become available, thereby allowing the inclusion of these wastes into salmonid feeds to provide valuable proteins. Commercially available components in the wastes, such as pigments and chitin, are also being extracted for usage in animal feeds (Meyers, S.P. 1977).

It has long been established that crustacea contain astaxanthin (Johnson *et al.* 1980). Crustacea meals can also function as a source of various feeding stimulants (Meyers, S.P., Rutledge, J.E., and Sonu, S.C. 1973). An investigation into the usage of crustacea by-products as inexpensive sources of proteins, led to an the interest in these meals as a source of astaxanthin, and the possible use of these by - products as salmonid pigmenters (Meyers *et al.* 1973). Some of the crustacea investigated are listed in Table 2.6.1 below (Hari, R.K., Patel, T.R., and Martin, A.M. 1994).

Table 2.6.1 Natural Sources of Carotenoids Used in the Aquaculture Industry

Carotenoid Source
Shrimp extract
Krill
Copepod
Red Crab
Shrimp Waste
Krill Meal
Crab Meal
Crawfish meal
Shrimp meal
Raw mysid
Red Crab extract
Crawfish extract
Copepod extract

(Hari, R.K., Patel, T.R., and Martin, A.M. 1994)

The red crab *Pleuroncodes planipes* has a relatively high carotenoid content and was thought to be a suitable dietary additive to salmonid feeds (Spinelli, J., and Mahnken, C. 1978), and (Kuo, H.C., Lee, T.C., Kamata, T., and Simpson, K.L. 1976), and studies were carried out to determine its suitability as an additive. As the protein content in the crabs was very low, whole unprocessed waste is not suitable for addition to the diet, as was discovered in feeding trials carried out (Kuo *et al.* 1976). The development of a three stage extraction process allowed ~ 155 mg pigment per 100g of soybean oil to be obtained (Spinelli *et al.* 1978), therefore, the addition of this extract to commercial salmonid diets proved to be a very effective mode of pigmentation. Another source of astaxanthin that has been investigated is the Antarctic krill *Euphausia superba* (Fujita, T., Satake, M., Watanabe, T., Kitajima, T., Miki, W., Yamaguchi, K., and Konosu, T. 1983). Astaxanthin in this species occurs mainly as esters, making up approximately 61.5% of the total carotenoid content (Czeczuga, B. 1981). The extreme processes undergone by krill meal, are thought to be responsible for the low levels of pigmentation observed when krill meal is fed to fish (Ibrahim, A., Shimizu, C., and Kono, M. 1984). It has been observed however, that fish fed with raw krill showed a significantly higher rate of deposition of carotenoid pigments (Ibrahim A., Shimizu, C., and Kono, M. 1984).

In this country, the crustacean waste of the prawn *Nephrops norvegicus* is the most readily available. However, there has been little or no work published in this area.

In America the crawfish industry expanded rapidly during the 1970's, producing vast quantities of crawfish waste. Carotenoid analysis revealed concentrations of up to 196 µg of pigment per g of dry tissue, in the claw of the crawfish *Procambarus clarkii* (Meyers, S.P. 1977). One of the techniques developed for the extraction of astaxanthin from the waste employs a soy oil process. The whole crawfish waste is ground up, the comminuted crawfish waste is mixed with water, the pH is adjusted with an acid or alkali and an enzyme is added to the solution. The solution is then stirred, heated and hydrolysed. After hydrolysis, the astaxanthin is extracted with oil, and the astaxanthin enriched oil is recovered by centrifugation (Johnson *et al.* 1993). The cost of the natural isolate of astaxanthin from the crawfish waste can cost between \$5,000 to \$15,000 per kg, therefore, while the crawfish wastes provide

a good source of the pigment, the high cost is somewhat of a deterrent to the usage of this waste on a wider scale (Johnson *et al.* 1993).

In Norway, shrimp (*Pandalus borealis*) wastes have been used traditionally as natural pigment sources for salmon and trout (Torrissen *et al.* 1989). Carotenoid levels are quite low however (0 to 200 mg/kg), and satisfactory pigmentation of the salmonids requires the addition of 10 to 25% by weight of the chitinous extract to the diet (Johnson *et al.* 1991). Shrimp meal dried at a high temperature has no effect on salmonid pigmentation, while the use of vacuum dried meal from shrimp wastes has been shown to enhance both the flavour, and colour of the fish (Meyers, S.P. 1977). Both sun dried shrimp waste and fresh shrimp waste was also shown to significantly improve the pigmentation of pen-reared salmonids (Meyers *et al.* 1971). There are many variations in the quality of shrimp meal depending on their sources. It must be remembered that the processing technique used, as well as the storage temperature, light, moisture content and oxygen concentration will all have an effect on the pigment concentration, and must be noted (Meyers *et al.* 1971). Even though there are high levels of moisture, ash and chitin, shrimp wastes are widely seen as a very useful natural source of astaxanthin. As with the extraction of astaxanthin from crawfish waste, a process has been developed which allows the extraction of the pigment into an edible oil (Anderson, L.K. 1975). The extraction of carotenoid pigments from crustacean wastes is accepted to be the best way to utilise the waste.

Crustacean waste has the potential to be a very marketable natural source of astaxanthin, but this may depend on;

- Careful processing of the meals, to produce a product with a sufficiently high level of carotenoids, in a stable form that could be absorbed readily by the fish. The processing would also need to remove raw materials that are of no benefit to the nutritional value of the feed;

- A cost effective technique for the extraction of astaxanthin, producing a stable compound, will also need to be developed.

2.7 Bacteria as Astaxanthin Sources

There are two known species of non - photosynthetic bacteria that contain astaxanthin. One of these is *Mycobacterium lacticola*. This organism reportedly forms the pigment only in a hydrocarbon medium, but not on nutrient agar (Nelis, H.J., and deLeenheer, A.P. 1989). The other species *Brevibacterium* 103 yielded, when grown on kerosene, 3g of cells per litre, with a pigment content of only 0.03 mg / g (Hsieh, L.K., Lee, T.C., Chichester, C.O., and Simpson, K.L. 1976). There are several drawbacks in using bacteria as sources of astaxanthin and these include;

- The low yield of pigment that can be obtained from the cells;
- Availability of other organisms, for example *Phaffia rhodozyma* and *Rhodotorula rubra*, that contain high levels of astaxanthin.

In view of the drawbacks mentioned, a future biotechnological application of either of the above bacteria appears unlikely.

The industrially important xanthophylls, canthaxanthin and zeaxanthin are produced by strains of *Brevibacterium* (Nelis *et al.* 1989), and *Flavobacterium* (McDermott, J.C., Brown, D.J., Britton, G., and Goodwin, T.W. 1974). However, the productivity is too low for commercial fermentation.

The detailed work that has been carried out on *Phaffia rhodozyma* because of it's commercial potential as a source of trans - astaxanthin, has prompted other searches for the occurrence of the pigment in other living organisms.

Members of the halobacteriaceae are characterised by both their sodium chloride and complex nutritional requirements (Gibbons, N.E. 1969), (Lanyi, J. 1974), and (Bayley, S.T., and Morton, R.A. 1978), and their red to orange pigmentation, due mainly to the presence of carotenoids. The most recent work carried out investigating the usage of a bacterium as a possible astaxanthin source, involved the use of the halobacteria, namely *Halobacterium salinarium*, *Haloarcula hispanica*, and *Haloferax mediterranei* (Calo, P., de Miguel, T., Sierio, C., Valazquez, J.B., and Villa, T.G. 1996). Each of the halobacteria used in the tests contained high amounts of ketocarotenoids. The chromatographic profile of the different halobacteria studied, showed that all of

them were able to synthesise C⁴⁰ carotenoids that are very close to astaxanthin in the accepted pathway, such as 3 - hydroxy - echinenone (Johnson *et al.* 1991). The three species of halobacteria used in the study, all accumulated carotenoids in varying amounts. *Halobacterium salinarium* produced 2400 µg of total carotenoids per gram of dried bacteria, including 265 µg of trans-astaxanthin (11%), and 588 µg of 3-hydroxy-echinenone (24%). *Haloarcula hispanica* produced up to 1350 µg per µg⁻¹ total carotenoids, 45% of which corresponded to C⁴⁰ carotenoids, and of these, 162 µg were 3-hydroxy-echinenone, but only 17 µg were trans-astaxanthin. *Haloferax mediterranei* synthesised 700 µg g⁻¹ total carotenoids, including 231 µg of 3-hydroxy-echinenone, but no trans astaxanthin was detected. *Phaffia rhodozyma* was analysed using the same HPLC method as was used with the halobacteria. The strain of yeast used was UCD-FST-67-210. *Phaffia rhodozyma* produced almost 300 µg g⁻¹ total carotenoids, of which 50 µg were 3-hydroxy-echinenone and 214 µg of trans-astaxanthin.

The results reported in this paper have interesting future implications. The levels of trans-astaxanthin obtained in *Halobacterium salinarium* were higher than the levels of trans-astaxanthin obtained using the strain of *Phaffia rhodozyma* tested, indicating that this organism is a natural source of the pigment with very good commercial possibilities. The levels of 3-hydroxy-echinenone, a ketocarotenoid close to trans-astaxanthin, was found in *Halobacterium salinarium* in higher amounts than have been obtained for shrimp meal, and further underlines the potential industrial significance of this bacterium. Other factors which make this organism a very attractive natural source of trans-astaxanthin include;

- the extreme sodium chloride concentrations (~20%) used in the growth medium, prevents contamination with other organisms; thereby making sterilisation procedures less rigorous;

- Sodium chloride concentrations under 15% induce bacterial lysis, so that no special cell breakage technique eg. mechanical or enzymatic is necessary.

These factors combine to make the organism *Halobacterium salinarium* the most exciting biological source of astaxanthin since the discovery of *Phaffia rhodozyma*, with a definite possibility that this organism will be developed for

use on a wide scale as a salmonid pigments. The positive results obtained using *Halobacterium salinarium* also show that sampling from extreme environments would be useful in yielding other possible sources of carotenoids. Carotenoids function in heterotrophic microorganisms as protectants against oxygen radicals and light (Krinsky, N.I., and Deneke, S.M. 1982), and environments in which radicals may be exacerbated, such as hot springs and mineral-rich illuminated desert ponds, may potentially yield organisms with a high potential for the production of astaxanthin and other valuable carotenoids.

2.8 Plants and Algae as Astaxanthin Sources

Carotenoid pigments can be extracted from many natural sources, including plants. An inherent problem with using plants as a source of pigment, is the seasonal and geographic variations that occur (Bell, E.R., and White, E.B. 1989). Some flowers do contain astaxanthin, and studies have been conducted using floral parts from the flowers *Tagetes erecta* and *Circubita maxima marica* (Lee, R.G., Neamtu, G.G., Lee, T.C., and Simpson, K.L. 1978), and the *Adonis* species (Kamata, T., Tanaka, Y., Yamada, S., and Simpson, K.L. 1990). Some of the results obtained in the studies using the *Tagetes* and *Ciscubita* species were disappointing. However, the results obtained using the *Adonis aestivalis* flower were better than expected and further studies were conducted.

The *Adonis* flower is a pretty, bright red colour, with the flowers having many bright red petals. In wild species however, the flower heads have few petals. The amount of astaxanthin compared to the total mass of the plant is quite small, therefore this plant was not considered a viable source for commercial cultivation. However, a patented system has been established which produces a strain of the flower containing much higher numbers of petals on the flower head, thereby making the use of this plant as a potential commercial source of astaxanthin quite possible. The extraction process for the removal of astaxanthin from the plant tissues of the *Adonis* was a two stage process, with the pigment being extracted into an oil solution or encapsulated in liquid and/or gelatin. Studies carried out using *Adonis aestivalis* showed that the pigmentation efficiency of the extracted astaxanthin was almost 80% of that of the synthetic source of the pigment (Kamata *et al.* 1990).

The production of carotenoid pigments from algae has been established (Borowitzka, L.J., and Borowitzka, M.A. 1990), with the production of β -carotene from *Dunaliella salina* in an open pond system. Feeding trials using algae that were added to the salmonid feed as a pigment source showed that there was a low uptake of pigments by the fish (Kvalheim, B., and Knutson, G. 1985). Many different species of algae have been investigated as potential sources of astaxanthin with a view to commercial development (Johansen, J.E., Svec, W.A., and Liaaen-Jensen, S. 1974), (Choubert, G. 1979), (Grung, M., DeSouza, F.M., Borowitzka, M.A., and Liaaen-Jensen, S. 1992), and (Wettern, M., and Weber, W. (1979)).

Some of the more promising algal species investigated are *Neochloris wimmeri* (Brown, T.E., Richardson, F.L., and Vaughn, M.L. 1967), *Chlamydomonas nivalis* (Cyzgan, F.C. 1968), and *Dictyococcus cinnabarinus* (Dentice Di Accadia, F., Gribanovski-Sassu, O., and Lozano-Rayes, C.N. 1968). The most promising results using algae as an astaxanthin source, have been obtained in recent studies carried out using the green alga *Haemotococcus pluvialis* (Bubrick, P. 1991).

The genus *Haemotococcus* (*Chlorophyceae*) has an interesting developmental cell cycle (Wollenweber, W. 1907), (Peebles, F. 1909), and (Elliot, A. 1934). Under favourable conditions cysts germinate, releasing from 2 to 64 red or green biflagellate swimmers with a characteristic cell wall. The wall appears as a halo, separated from the plasma membrane but connected to it by a series of cytoplasmic strands. During periods of stress the cells round up, lose their flagellae, and form a thick persistent cyst wall. Concomitantly, cells begin the massive accumulation of astaxanthin. Astaxanthin deposition is first noted around the nucleus, and proceeds radially until the entire protoplast is red. The two processes, encystment and astaxanthin deposition, while usually coupled, are in fact distinct processes (Bubrick, P. 1991). Fully mature cysts can contain up to 5% by weight astaxanthin, predominantly in the form of monoesters of fatty acids (Czygan, F.C. 1968), and (Renstrom, B., and Liaaen-Jensen, S. 1981).

Haemotococcus pluvialis has a high concentration of astaxanthin (0.5 to 2% astaxanthin on a dry weight basis) (Johnson *et al.* 1991). Of the total astaxanthin concentration, 87% occurs esterified, which may affect its

deposition in some animals. Like other natural sources of the pigment, this one also has its limitations which include;

- Lengthy autotrophic cultivation of the alga in open freshwater ponds is needed, to produce sufficiently high levels of astaxanthin in the cells;
- The cell wall of the alga is extremely thick, and rupturing is needed in order to extract the pigment;
- Contamination of the cultivation (open pond) system with foreign algae, and protozoal predators has been a problem in tests carried out using this organism.

Despite these limitations however, processes have been developed which rupture the cell wall barrier to release the pigment (Bubrick, P. 1991). These processes include enzymatic treatment (Grung *et al.* 1992), and cryogenic fracturing of the cell wall (Bubrick, P. 1991), and (Spencer, K.G. 1989). The patented process (Spencer, K.G. 1989), allows the cryogenic grinding of the cells to take place by first mixing the dry cysts with liquid nitrogen and a suitable antioxidant, and then grinding the cysts at a temperature of -170°C . This dry algal powder is sold under the brand name of "Algaxan Red" (Bubrick, P. 1991), and is a successful pigmenter of salmonids when added to feeds.

2.9 Yeasts as Astaxanthin Sources

Yeasts form one of the most important sub-groups of the fungi (Rose, A. 1987). They exist in single small cells ranging from 5 to 30 μm long, and from 1 to 5 μm wide (Bailey, J.E., and Ollis, D.F. 1986). Yeasts are generally considered to be a highly nutritious feedstuff, although the presence of a tough cell wall only allows the nutrients to be moderately available to animals (Rumsey, G.L. 1988). The disruption of the cell wall enhances the availability and digestibility of the nutrients, although separating the cell wall material from the other cellular components does not increase the nutritional value (Rumsey, G.L. 1988). The cell wall of yeasts contain β - 1, 3 - glucans, which are known

to be stimulants of fish immune systems, enhancing the effectiveness of fish vaccines (Rorstad, G., Robertson, B., and Rae, J. 1992).

Astaxanthin is found in only a few yeast genera. One of the first shown to contain astaxanthin as its major carotenoid was *Peniophora*, (Goodwin, T.W. 1972), with *Peniophora hypnoides*, *Peniophora quernica* and *Peniophora aquatica* all having astaxanthin present. The genus *Rhodotorula* is known to have a red colouration due to the presence of carotenoids like torularhodin and torulene (Nakayama, T., McKinney, G., and Phaff, H.J. 1954). Neither of these two pigments can be transformed by salmonids into astaxanthin (Savolainen, J.E.T., and Gyllenberg, M.G. 1970).

A new strain of *Rhodotorula rubra* has recently been isolated from yoghurt (Hari, R.K., Patel, T.R., and Martin, A.M. 1992), which contained astaxanthin as its primary carotenoid, and which it was claimed could be used to pigment salmonids.

Work has been carried out using this yeast, which has shown that this organism contains astaxanthin as its primary carotenoid. Recent research has determined that the pigmentation in this yeast is found to occur after the growth of the organism had stopped. This is the direct opposite to the case with *Phaffia rhodozyma*, where the production of pigment is growth related (Acheampong, E.A., and Martin, A.M. 1995). A recent study looked at the kinetics of growth and pigment formation by *Rhodotorula*, in comparison with *Phaffia rhodozyma*. The researchers found that the use of a mechanical method of cell breakage (French Press), allowed twice as much pigment to be extracted from *Rhodotorula rubra* as was extracted from *Phaffia rhodozyma*. The use of an enzyme 'Funclase' to rupture the cell walls, allowed no release of astaxanthin from *Rhodotorula rubra*, while the *Phaffia rhodozyma* cells treated with this enzyme yielded almost 362 µg of pigment / g dry weight of cells. This study showed that *Phaffia rhodozyma* is an excellent source of carotenoid pigments. However, since the cell walls of *Rhodotorula rubra* were not susceptible to enzymatic treatment, this means that the cells would need to be ruptured using another method, possibly mechanical. This process would be time consuming, and could reduce the economic viability of the yeast, along with making the organism a less attractive source for possible industrial application.

The only red pigmented yeast which is known to contain astaxanthin, is *Phaffia rhodozyma*. *Phaffia rhodozyma* was first isolated in the 1970's by Phaff *et al.* (1972) from the exudates of deciduous trees in Alaska, Japan, and the U.S.S.R. (Phaff, H.J. 1986). Ten strains were isolated all of which had colonies ranging in colour from orange to red, and the name *Rhodozyma montanae* was first proposed, since the strains were all found in mountainous areas. However, since a latin diagnosis had not been given this name was not recognised (as required by the International Code of Botanical Nomenclature), and in 1976, the yeast genus was named *Phaffia rhodozyma*, in honour of many years of research in yeast biology by Herman J. Phaff, who first isolated the organism (Johnson *et al.* 1991). All ten strains were represented by a single species. A full latin diagnosis and a complete description was given (Phaff *et al.* 1972).

Phaffia rhodozyma has several unique characteristics, principally in its fermentative capabilities, unusual carotenoid composition and cell wall composition. Other investigators have found *Phaffia rhodozyma* in nature. 67 strains of the yeast were isolated from birch fluxes in the Moscow region of Russia (Golubev, W.I., Babjeva, I.P., Blagodaskaya, V.M., and Rashedova, I.S. 1977). The yeast has been isolated exclusively from broad-leaved trees in limited geographic regions of the world (Phaff, H.J. 1990).

Phaffia rhodozyma is basidiomycetous in origin. Its basidiomycetous relationship was elucidated by the demonstration of a multi-layered cell wall, and enteroblastic budding (Miller *et al.* 1976). Its basidiomycetous affinity is also supported by the carbohydrate composition of the cell wall (Weijman, A.C., de Miranda, L.R., and van der Walt, J.P. 1988). Vegetative *Phaffia rhodozyma* cells form buds as heterobasidiomycetous yeast. Chlamydospores are developed by budding, but promycelium and proper spore formation do not occur. The chlamydospores are relatively large, spherical cells, with a larger lipid content than the vegetative cells. Attempts to pair the various strains of the yeast together, in the hope of observing dikaryotic mycelium and teliospore formation, have not been successful (Miller *et al.* 1976). Vegetative cells are ellipsoidal (3.6 - 7.5) x (5.5 - 10.5) μm , and are present in a liquid medium individually, in pairs, in short chains, or in clusters. Budding occurs several times from the same point on the cell. The multi-layered cell wall causes the clustering effect often seen with *Phaffia rhodozyma* cells. A sexual life cycle for *Phaffia rhodozyma* has only recently been demonstrated with *Phaffia*

rhodozyma producing haploid spores of a sexual origin (Villadsen, I.S. 1992). The sexual life cycle discovered for *Phaffia rhodozyma* is shown below.

Figure 2.9.1 Sexual Cycle of *Phaffia rhodozyma*

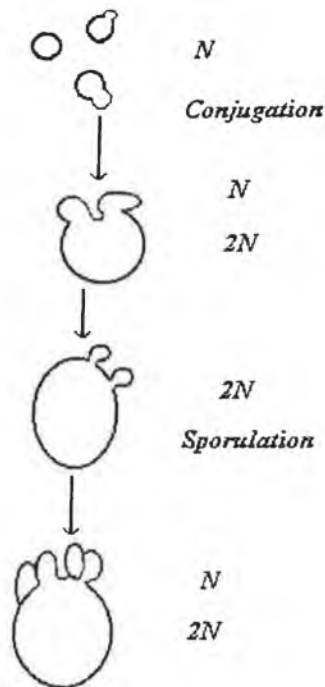

(Villadsen, I.S. 1992)

When *Phaffia rhodozyma* was grown in shake flasks containing a Yeast Malt medium at 21 C, 2-3 types of cells can be distinguished, depending on the stage of growth. On examination of the culture at the break-point of the exponential and stationary growth phase, 2-4 round bodies were observed. Using a conventional spore stain called Methyl Green, the green asci appearing in the stationary phase were coloured green, indicating the presence of sexual spores in the stationary phase. Analysis of *Phaffia rhodozyma* cells was also carried out using a SKATRON flow cytometer, to further prove that the yeast exhibited a sexual cycle. The cells were also stained with DAPI, a conventional stain used for DNA. The small haploid spores could clearly be seen.

In a final demonstration of the sexual cycle in the yeast, *Phaffia* was grown in a complex medium containing urea (not ammonia), as the accessible nitrogen source. In ammonia-containing media, sporulation is less prominent. Another requirement for sporulation is the presence of all amino acids, and the bases

uracil and adenine. Without these bases, the cells may conjugate, but not sporulate. Cells in the urea containing medium sporulated, with the haploid cells clearly being seen. This discovery has led to the conclusion that, since the content of astaxanthin is highest in the late stationary phase, these haploid cells contain the pigment.

The genus *Phaffia* is characterised by the synthesis of carotenoid pigments, production of cell surface-associated amyloid compounds, a co-enzyme Q-10 system, and the ability to ferment sugars. This yeast also has the ability to assimilate a vast range of carbon compounds, including; D-glucose, maltose, sucrose, cellobiose, trehalose, raffinose, soluble starch (latent or negative), ethanol (latent or negative), α - methylglucoside (latent or negative), D-mannitol, salicin (weak), 2-ketoglucinate, D2-lactate (latent), succinate, and glycerol (weak). The optimum temperature of growth for the yeast is 20 - 22 C. It's mol % G + C is 48.3 + 0.18 . The yeast does not grow on lactose, galactose, glucosamine, D-ribose, or D-arabinose, and does not utilise nitrate, but does hydrolyse urea (Johnson *et al.* 1991).

The yeast produces astaxanthin, while nearly every other coloured yeast contains β -carotene or monocyclic carotenes. Even the absolute configuration of astaxanthin from *Phaffia rhodozyma* is unusual, being (3S, 3'S), except for the krill *Euphausia superba*. The carotenoid composition of *Phaffia rhodozyma* is shown Table 2.9.1 (Andrewes, A.G., Phaff, H.J., and Starr, M.P. 1976).

Normally, most naturally occurring carotenoids are not biosynthesised in different isomeric forms, but it is postulated that different biosynthetic pathways operate in various organisms (Bitzer, R.R. 1963).

Table 2.9.1 Carotenoids of *Phaffia rhodozyma*

CAROTENOID	% OF TOTAL CAROTENOID
Astaxanthin	ca 83 to 87
Phenicoxanthin	ca 5 to 7
3 - Hydroxyechinenone	ca 3 to 4
β - carotene	ca 2 to 2.5
Echinenone	ca 2 to 4
3 - Hydroxy - 3', 4'- didehydro - β - ϕ - carotene - 4 - one (HDCO)	ca 0.3 to 0.5
Lycopene	ca 0.01
Neurosporene	ca 0.01
α - carotene	ca 0.01

(Andrewes et al.1976)

The biosynthetic pathways from phytene to astaxanthin, have been indirectly inferred by the chemical identification of various compounds in the organisms. Usually, pathways are proposed based on a logical sequence of biosynthetic events;

DESATURATION -----> CYCLIZATION -----> OXYGENATION

The enzymes catalysing these steps have not been isolated in astaxanthin-producing organisms, and the actual sequence of reactions and precursors is not known with certainty (Johnson *et al.* 1991). It is thought that two biosynthetic pathways exist for astaxanthin in *Phaffia rhodozyma*. The first pathway was proposed by Andrewes *et al.* (1976), and is shown in Figure 2.9.2

The condensation of two-molecular geranyl geranyl pyrophosphate forms phytophene, which via dehydrogenation steps and ring-forming, forms astaxanthin from β -carotene. The last part of the biosynthesis has not been unambiguously determined.

The second pathway (shown in Figure 2.9.3), leads to a mixture of cis and trans astaxanthin, and has been postulated for a mutated strain of the yeast (Johnson *et al.* 1991).

Figure 2.9.2 Postulated Biosynthetic Pathways for Astaxanthin by *Phaffia rhodozyma*

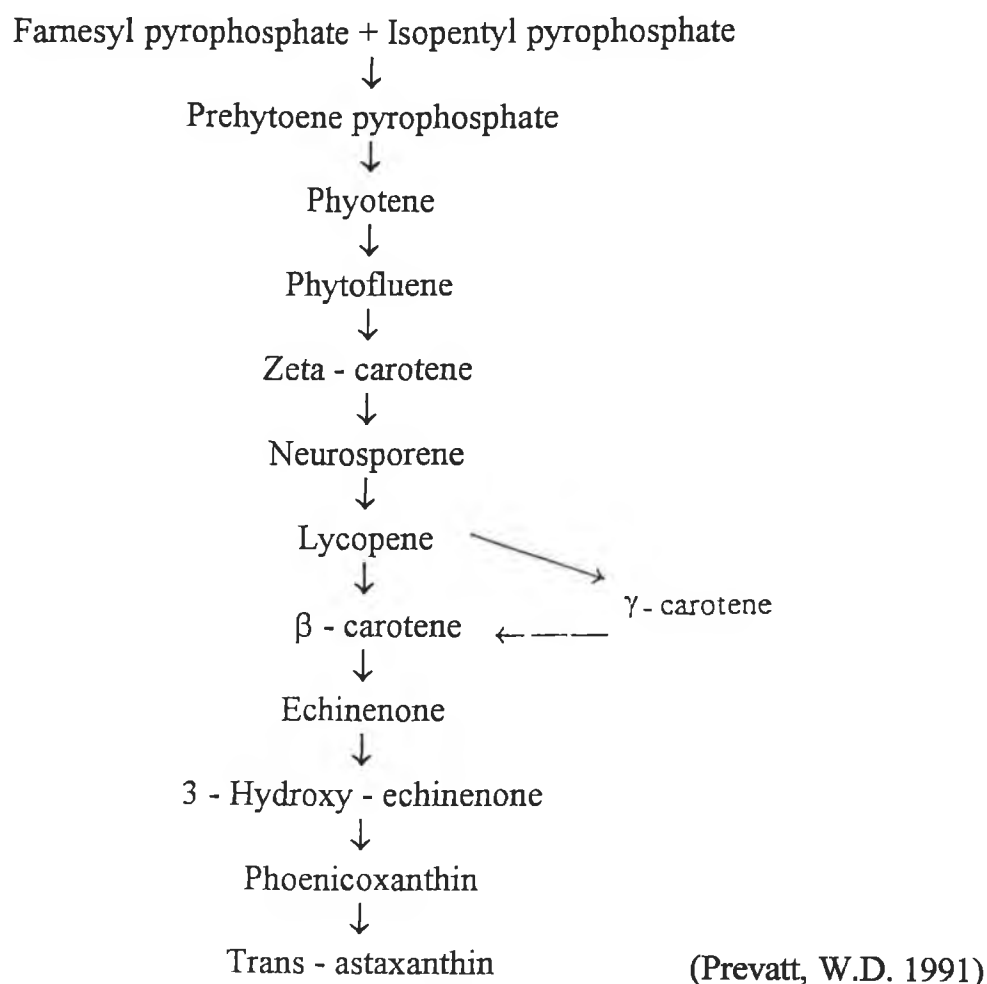

Recent work carried out in America, has shed further light on the biosynthesis of astaxanthin by *Phaffia rhodozyma*. A previously unreported carotenoid, which has been labelled "half-astaxanthin" (3-hydroxy-3', 4'-didehydro- β , ψ -caroten-4-one), was found in *Phaffia rhodozyma*. It was postulated that this compound was formed as a side-product during astaxanthin synthesis, from γ -carotene (Prevatt, W.D. (1991)).

Figure 2.9.3 Postulated Pathway for Astaxanthin by a Mutant Strain of *Phaffia rhodozyma*

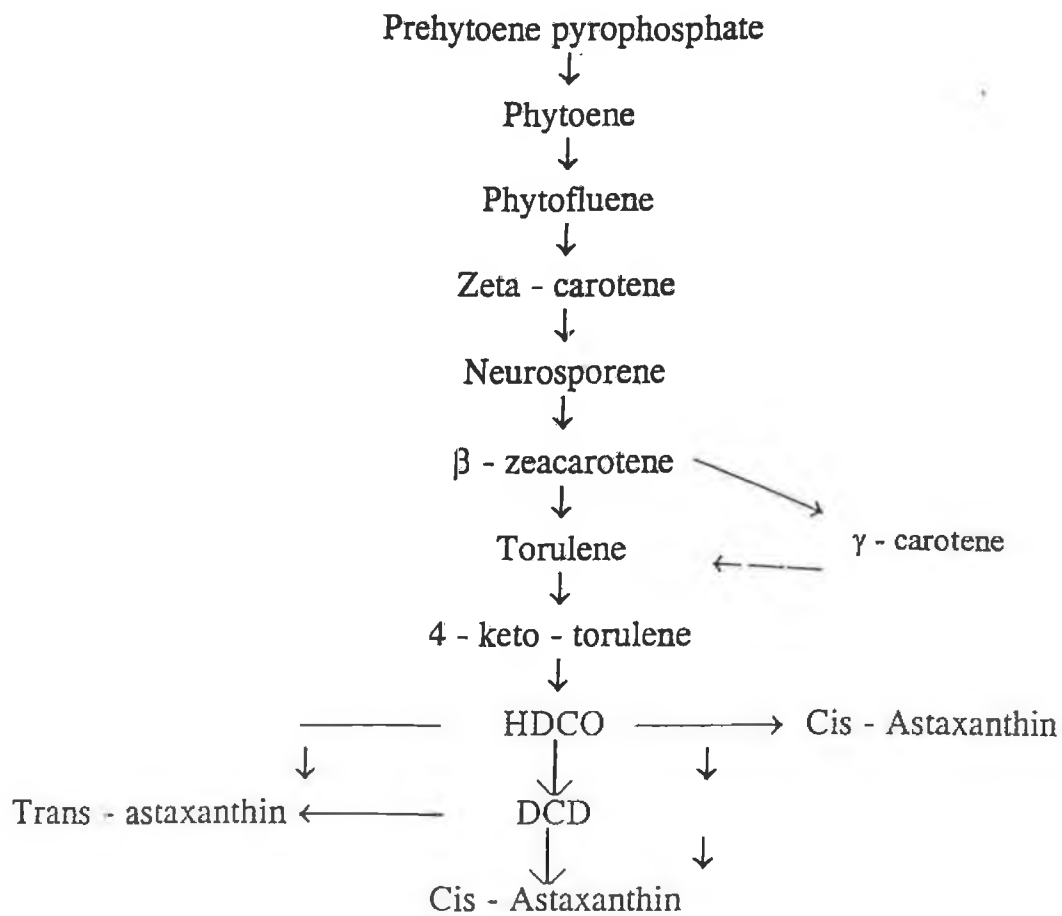

(Prevatt, W.D. 1991)

Figure 2.9.4 Biosynthetic Pathway for Astaxanthin in Crustaceans

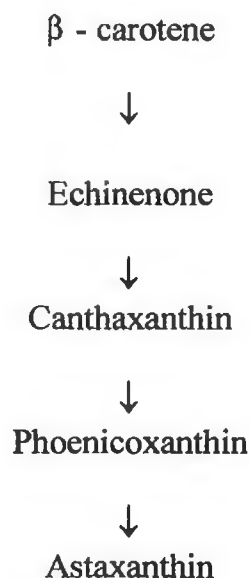

(Meyers, S.P. 1977)

The pathway by which crustaceans synthesise astaxanthin, is shown in Figure 2.9.4

Given the high astaxanthin content of *Phaffia rhodozyma*, investigations into its possible use as a pigment source, have been carried out in detail (Johnson *et al.* 1991). The pigmentation efficiency of the yeast was found to be excellent. Although the cell wall and capsule appears to be indigestible (Okagbue, R.N., and Lewis, M.J. 1983), the astaxanthin is biologically available if the cell walls are ruptured. Mechanical breakage of the cells, and enzymatic digestion of the yeast cell walls, are the two most commonly employed methods used to release the pigment (Johnson *et al.* 1991). Both methods have been used successfully to liberate the astaxanthin from the cells, although major drawbacks to the use of mechanical methods are; the length of time that the process takes, and the cost involved in providing cooling for the procedure.

Wild strains of astaxanthin contain up to 800 µg of astaxanthin per gram of yeast, depending on the strain used and method of culture. Recent advances in mutating the yeast, means that there is an immense potential for *Phaffia rhodozyma*, as a feed supplement for cultured salmonids, with the possible production of the pigment from the yeast on a large scale.

Phaffia rhodozyma is also known to be a good source of glucan (Rorstadt *et al.* 1992), which stimulates the immune system of salmonids, to protect them against disease. For these reasons, much effort has been put into the development of *Phaffia rhodozyma*, as a salmonid feed additive, and this will now be discussed in detail.

2.10 Development of *Phaffia rhodozyma* as a Source of Astaxanthin

There have been many studies carried out investigating the use of *Phaffia rhodozyma* as an astaxanthin source (Johnson *et al.* 1977), (Johnson *et al.* 1978), and (Johnson *et al.* 1979), the effect of a culture conditions on the formation of astaxanthin (Johnson *et al.* 1991), (Okagbue, R.N., and Lewis, M.J. 1984), (An, G.H., Schumann, D.B., and Johnson, E.A. 1989), (Acheampong, E.A., and Martin, A.M. 1995), and (Fang, T.J., and Chen, Y-Shin. 1993), the isolation and extraction of astaxanthin from the yeast cells (Prevatt, W.D. 1991), (Okagbue *et al.* 1985), (Johnson, E.A., Villa, T.G., Lewis, M.J., and Phaff, H.J. 1979), and (Ravinder *et al.* 1995), and the use of alternative carbon sources and substrates (Martin, A.M., Acheampong, E., and Patel, T.R. 1993), (Okagbue R.N., and Lewis, M.J. 1984), (Hayman, G.T., Mannarelli, B.M., and Leathers, T.D. 1995).

Some of the alternative substrates that have been used to support growth, include alfalfa residual juice (ARJ), molasses, grape juice, peat hydrolysates, and corn wet-milling products. More sophisticated work has been carried out in the fields of mutagenesis, cloning, and protoplast fusion, aimed at developing higher astaxanthin - producing strains of *Phaffia rhodozyma*. Initial studies carried out on the use of *Phaffia rhodozyma* as an astaxanthin source, reported a rate of incorporation into salmonid flesh that was faster than that reported previously for dried crustacean waste (Saito, A., and Regier, L.W. 1971). Johnson *et al.* 1980), reported that no astaxanthin appeared to be nutritionally available to the fish from intact yeast, since the fish could not digest the tough cell walls. Rupturing the cells prior to addition to the feed, affects both the fish growth and pigmentation, suggesting that the nutrient availability is increased.

2.10.1 Culture Conditions

There have been many studies investigating the effect of culture conditions on growth and pigment production by *Phaffia rhodozyma*, which found that there were differing results obtained for shake flasks and fermenters. The duration of astaxanthin synthesis, growth of *Phaffia rhodozyma*, and glucose utilisation were studied by sampling identically prepared shake flasks over a 61 hour time period (Johnson *et al.* 1979). The growth of *Phaffia rhodozyma* was found to have a lag phase of 6 hours, followed by a period of rapid growth, with a constant value being obtained after approximately 40 hours. Growth and astaxanthin synthesis ceased when the glucose was exhausted from the medium, as the production of pigment took place mainly during the exponential phase of growth. On closer examination, the formation of carotenoids in a batch culture showed that carotenes are sufficiently oxygenated during the exponential phase of growth, with the formation of xanthophylls proceeding virtually to completion during the stationary growth phase.

In both fermenter and batch cultures, it has been shown that the growth of *Phaffia rhodozyma*, and rate of astaxanthin production, were affected by the pH of the growth medium (Johnson E.A. 1978), (Johnson *et al.* 1979) , and (Johnson *et al.* 1980). In shake flask cultures, the maximum yield of astaxanthin was found to occur at a pH of 5.0, with the optimum pH for the growth rate of the organism occurring at a pH of 5.8. Overall however, within a pH range of between 4 to 7, the buffer chosen had a greater effect on growth and pigment yield than the pH did (Johnson *et al.* 1979). In fermenter cultures, the pH is controlled by automatic titration (of either an acid or an alkali), and this led to a slightly different result. Johnson *et al.* (1979) found that the maximum yield of cells, the maximum production of astaxanthin and the highest growth rate, all occurred at a pH of 4.5. In a later study carried out by Meyers P.S., and du Preez, J.C. (1994), it was claimed that the pH only affected the cell growth of *Phaffia rhodozyma*, which was a contradiction of the earlier work carried out by Johnson *et al.* (1979). However, in a study conducted in 1995 using a fermenter, it was stated that the pH did in fact have a major influence on both cell growth and pigment production, with the optimum pH for maximum pigment yield and cell growth found to be 4.0 (Harvey, D., and Larsen, V.F. 1995). A pH of 4.0 is a low optimum compared with those reported by other workers, but this study served to confirm the importance of pH on growth and pigment production by *Phaffia rhodozyma*.

Phaffia rhodozyma is known to grow in the temperature range from 0 to 27°C (Johnson *et al.* 1991). Johnson *et al.* (1979), found that optimum growth and pigment production was obtained at a temperature of 22.5°C. Above this temperature there is a substantial decrease in the growth of the organism. In tests carried out where the incubation temperature was raised from 20°C to 30°C, the chief carotenoids produced were torulene, and torularhodin, with very little astaxanthin being produced at this temperature (Polulyakh, O.V., Podoprigova, O.I., Eliseev, S.A., Ershov, Yu.V., Bykhovskii, V.Ya., and Dmitrovskii, A.A. 1992). Johnson and Lewis (1979) found that the yield of astaxanthin was relatively constant at all the temperatures, at around 480 µg astaxanthin / g dry weight of yeast. The fact that *Phaffia rhodozyma* cannot grow at a high temperature, is a distinct disadvantage to the industrial development of the organism. Attempts to produce mutants of the yeast that can grow at higher temperatures, have not been successful (Johnson *et al.* 1979).

The effect of light on the production of astaxanthin by *Phaffia rhodozyma* has also been studied. According to Johnson and Lewis (1979), light has no substantial effect on the production of astaxanthin by the yeast. In a later study carried out (An, G.H., and Johnson, E.A. 1990), it was found that light affected growth and pigment production, with high light intensities inhibiting growth and pigmentation. At the lower light intensities used, carotenoid formation was induced. It has also been proven that astaxanthin production in *Phaffia rhodozyma* mutants is photo inducible (Meyer, P.S., and du Preez, J.C. 1994). The final astaxanthin concentration obtained was determined by the total time of illumination, the growth phase subjected to illumination, and the light intensity. Maximum astaxanthin production was obtained when cultures were continuously illuminated during the exponential growth phase, using a light of moderate light intensity (5 to 100 µE.m⁻².S⁻¹). Interestingly, blue light was found to be primarily responsible for photo-induced astaxanthin production in *Phaffia rhodozyma*. Previous research has also found that the light response of *Phaffia rhodozyma* increased, when it was exposed to antimycin, with pigment production and the rate of growth both increasing in the presence of antimycin and light.

Antimycin is a respiratory chain inhibitor which it is thought increases the formation of oxygen radicals. The carotenoid pigments are known to act as biological antioxidants (Prevatt, W.D., Dickson, T.D., Vineyard, K.M., Harris,

R.L., and Just, D.K. 1991). It has been suggested that carotenoids may be formed in response to intracellular oxygen radical formation, as a type of defence mechanism (An, G.H., Schumann, D.B., and Johnson, E.A. 1989). Oxygen is vital to the formation of carotenoids in *Phaffia rhodozyma* (de Haan, A., Burke, R.M., and de Bont, J.A.M. 1991). The maximum astaxanthin level is found to occur shortly after the cessation of growth with an adequate oxygen supply, and even a tiny restriction can lead to a delay in astaxanthin synthesis. Stronger restriction leads to very slow astaxanthin synthesis, with β -carotene accumulating rather than astaxanthin. Johnson *et al.* (1979) found that low aeration led to low amounts of astaxanthin formation. With very low oxygenation (ca. 20 mmoles/l/h), the yield of cell mass also decreased. It can therefore be accepted that cell respiration is independent of the dissolved oxygen concentration, providing it is above a critical level, and the glucose concentration is low (Winzler, R. 1941).

The levels of glucose in the growth medium, also have an effect on biomass and astaxanthin production by *Phaffia rhodozyma*. It is thought that increasing the levels of glucose leads to a repression of respiration in yeasts, leading to a switch to fermentative respiration. In studies carried out by Johnson *et al.* (1979), and Johnson *et al.* (1980), it was discovered that the yield of yeast per gram of glucose utilised decreased significantly, with an increasing glucose concentration. This seemed to confirm the classical explanation of repressed respiratory activity. However, a more recent study used a low level of glucose (3 g/l, or 0.3%), in comparison with a low level of glucose (60 g/l, or 0.6%), to determine if *Phaffia rhodozyma* did indeed switch to a fermentative metabolism, due to high levels of glucose causing respiratory repression (de Haan *et al.* (1991)). Analysis for fermentative products such as glucose, acetate, and ethanol was carried out, as well the measurement of respiratory activity. Glycerol and ethanol were detected, but the amounts were so low in comparison with the amount of glucose consumed, that it was concluded that there was no repression of respiration occurring. Recent research has been carried out using mutants of *Phaffia rhodozyma*, where the yeast cells were exposed to slow feeding with a rapidly metabolised energy source, followed by feeding with a slowly metabolised energy source, such as glycerol (Jacobson, G.K., Jolly, S.O., Sedmak, J., Skatrad, T., and Wasileski, J. 1995). The yeast was grown initially using glucose as a carbon source, which was fed very rapidly to the cells. The feeding was controlled to prevent an accumulation of glucose in the nutrient medium. At the end of the growth phase, the cells were

slowly fed with an energy source that is metabolised much slower than glucose. This method was not previously employed, and allowed the stimulation of carotenoid synthesis during the non-growth phase; after the primary carbon source (glucose) had been utilised. This study found that using two different carbon sources, together with a manipulation of the growth curve of the yeast, allowed astaxanthin to be produced for much longer in the non-growth phase, than had been achieved previously. The study also showed that using the correct carbon source (or sources) to maximum effect, based on the knowledge available on the carotenoid production cycle of *Phaffia rhodozyma*, could be a very important tool in increasing astaxanthin productivity, thereby making the yeast a more economic and valuable industrial source of the pigment.

2.10.2 Nutrient Sources

Different carbon and nitrogen sources have been tested, to determine which supported the best growth, and pigment production by *Phaffia rhodozyma*. Johnson *et al.* (1979), found that cellobiose supported higher pigment levels than the other sources tested. Glucose, and maltose were shown to promote high levels of astaxanthin production, and rapid cell growth. Of the nitrogen sources tested, ammonium sulphate, peptone, and ammonium hydrogen phosphate used in various concentrations did not affect the rate of growth, the astaxanthin yield, or the final biomass yield obtained.

Studies have also been carried out with various carbon and nitrogen sources, using mutants of *Phaffia rhodozyma*. One particular study used a mutant that was created from the parent strain using NTG (N-methyl-N'-nitro-N-nitrosoguanidine) as a mutagenic agent. A wide range of carbon sources were tested, including glucose and a range of disaccharides. Various nitrogen sources were also used including peptone, urea, tryptone, beef extract, caesin hydrolysate, potassium nitrate and ammonium nitrate (Fang, T.J., and Cheng, Yi-Shin. 1993). It was found that glucose supported the highest total astaxanthin production (7809.3 µg/l). Yeast extract was the best nitrogen source in supporting the highest total astaxanthin formation (8637.5 µg/l). When a mixture of nitrogen sources was used, ie. a mixture of yeast extract, beef extract, and potassium nitrate (1:1:1), more growth and pigmentation was supported than with any of the other mixtures tested (8052.6 µg/l). This study demonstrated that although the astaxanthin concentration was lower in the culture using the yeast extract medium, the lower cost of the mixed nitrogen

medium makes it more attractive when large scale production is being considered.

2.10.3 Alternative Substrates and Carbon Sources

Several investigations have been carried out, into the use of alternative carbon sources and substrates for the cultivation of *Phaffia rhodozyma*. These include brewers malt wort (Okagbue, R.N., and Lewis, M.J. 1984), molasses (Haard, N.F. 1988), alfalfa residual juice (Okagbue, R.N., and Lewis, M.J. 1984), grape juice (Meyer, P.S., and duPreez, J.C. 1994), whey permeate (Fang *et al.* 1993), vegetable and citrus wastes (Johnson *et al.* 1979), peat hydrolysates (Martin, A.M., Acheampong, E., and Patel, T.R. 1993), and corn wet-milling by-products (Hayman, G.T., Mannarelli, B.M., and Leathers, T.D. 1995).

A complex medium was prepared by adding colourless tomato pressings to a standard growth medium in a 1:2 ratio. An increased yield in astaxanthin production by *Phaffia rhodozyma*, suggested that the tomato pressings could contain carotenoid precursors, which enhance carotenoid production (Johnson *et al.* 1979).

Alfalfa residual juice (ARJ), is a waste product derived from the commercial process which extracts protein from the leaves of the alfalfa plant. The alfalfa juice initially contained a high level of sugar (22%), and was extremely viscous, therefore it was diluted and clarified before use. This study also used brewers malt wort for comparison with the alfalfa juice (Okagbue, R.N., and Lewis, M.J. 1984). It was found that the ARJ supported good growth of the yeast, but that the formation of astaxanthin was inhibited. Concentrations of ARJ of above 1.25% (w/v) were inhibitory to pigmentation of the yeast, leading to the conclusion that ARJ contained an inhibitor of astaxanthin biosynthesis, most likely saponin.

This hypothesis led to a further study which determined the effects of commercial grade saponin on astaxanthin production (Okagbue, R.N., and Lewis, M.J. 1984). It was found that commercial grade saponin had a more toxic effect on the yeast, than the ARJ. Various concentrations of saponin in the range 0.02% to 0.5%, inhibited growth of the yeast, but even at a higher concentration of 0.5% saponin, total growth was not inhibited. It is thought that the inhibitory effect saponin has on *Phaffia rhodozyma*, could be due to

some disturbance in the integrity of the lipid-rich plasma membrane of the yeast. In testing this theory, it was found that certain unsaturated fatty acids (sterols, linoleic acid, and oleic acid), were effective in combating the inhibition caused by the saponin. This confirmed that the saponin adversely affected the permeability of the yeast cell wall membrane. This led to the inhibition of astaxanthin formation, since carotenoids in some fungi are associated with lipid globules and membranes (Mitzka - Schnabel, U., and Rau, W. 1980).

Molasses is also a substrate that has been investigated as an alternative growth medium (Haard, N.F. 1988). When *Phaffia rhodozyma* was grown on 7 to 10% grade B and C molasses, 2 to 3 times more astaxanthin than had been previously reported for the yeast was obtained. With 10% molasses as a substrate, a yield of 15.3 µg astaxanthin per ml was reported, which was twice as much as the yield of pigment obtained using a sugar blend representative of molasses, and three times higher than the yield obtained using glucose. Molasses is an inexpensive fermentation substrate, which is a promising material for the production of highly pigmented *Phaffia rhodozyma*, and as such, deserves further investigation.

Grape juice is a low cost raw material, due to the surplus available in certain wine regions (Meyer, P.S., and du Preez, J.C. 1994). *Phaffia rhodozyma* was successfully cultivated in grape juice, assimilating both glucose and fructose as carbon sources. Grape juice was deemed to be a suitable culture medium for *Phaffia rhodozyma*, with 9.8 µg/ml of astaxanthin being obtained. The growth conditions for maximum biomass production using this source as a culture medium were optimised (Longo, E., Sierio, C., Valasquez, J.B., Calo, P., Cansado, J., and Villa, T.G. 1992).

The use of whey permeate as a substrate, when mixed with a yeast extract, gave a superior performance to that of *Phaffia rhodozyma* cultured on a similar glucose or lactose containing media, with regard to the specific growth rate, astaxanthin, and biomass yields (Fang *et al.* 1993).

Another complex medium used as a substrate for culturing *Phaffia rhodozyma*, are peat hydrolysates, which have been used for a number of microorganisms, in a variety of fermentation processes. The hydrolysis of peat produces a variety of sugars in the liquid phase, one of which is cellobiose, and the peat

bitumen fraction contains potential astaxanthin precursors such as carotenes and xanthophylls (Martin *et al.* 1993). The peat hydrolysate produced with acid, at a temperature of 185°C, was found to be a good substrate for yeast growth and pigment production. Using an initial total carbohydrate concentration in the substrate of 15g dm⁻³, the optimum growth conditions determined were; an initial pH of 7.0, an incubation temperature of 18°C, a fermentation time of 120 hours, and an agitation speed of 200 rpm, a maximum astaxanthin yield of 1567 µg g⁻¹ dry yeast was recorded.

More recent work investigating alternative substrates for the cultivation of *Phaffia rhodozyma*, has looked at the possible use of media composed of corn wet-milling by-products. The processing of corn by wet milling for fuel ethanol, generates several co-products that are of proven and potential interest as low cost growth medium components, for the production of value added products by microorganisms (Leathers, T.D., Gupta, S.C., Hayman, G.T., Rothfus, J.A., Ahlgren, J.A., Imam, S.H., Wu, Y.V., and Greene, R.V. 1992). Milling kernels yields primarily starch (and separates the germ, which is sold for oil extraction and is the most valuable product of the process), and corn fibre (CF), (which is mainly composed of the seed pericarp), or corn bran. Bran contains 70% xylan, 23% cellulose, and 1% lignin. Gluten (G), the second most valuable product, is separated from the starch by centrifugation, which forms a gluten wet cake (GWC), which is dried into gluten, and sold as a chicken feed additive. The starch is saccharified to glucose, combined with the steep water as a diluent, and a nutritional additive, and is fermented by yeast to ethanol. After fermentation, the remaining thin stillage (TS), a major product of the process, containing ~ 2.2% carbohydrate (after clarification), is evaporated to form corn condensed distiller's solubles (CCDS). This co-product, which contains ~ 18% protein, and ~ 20% carbohydrate, is sprayed onto the CF and fermented to generate corn gluten feed (CGF), which is sold as cattle fodder.

These six wet milling products (G, GWC, TC, CCDS, CF, and CGF), were tested as substrates for biomass production and carotenoid yield by *Phaffia rhodozyma*. All of the six co-products tested cost between \$0.02 per kg, to \$0.11 per kg, all less expensive than the conventional or agricultural growth substrates previously tested (Hayman, G.T., Mannarelli, B.M., and Leathers, T.D. 1995).

The three co-products that allowed the greatest accumulation of biomass and carotenoids by *Phaffia rhodozyma*, were thin stillage (TS), with 4 µg/ml total carotenoids, corn condensed distiller's solubles (CCDS), with 3 µg/ml total carotenoids, and the corn gluten feed (CGF), with 2.9 µg/ml being achieved. Of the three co-products that supported the most pigment production (mainly astaxanthin and β-carotene), TS and CCDS were found to be of the greatest interest, since they supported optimal pigment yields, and are the predominant, low cost co-products of fuel ethanol production by corn wet milling. The use of these co-products as a simple and inexpensive growth medium, would reduce the cost of yeast-produced carotenoids, and increase the commercial viability of *Phaffia rhodozyma* as a source of astaxanthin.

2.10.4 Cell Disruption

The structure of the yeast cell wall needs to be altered in some way, in order to make the pigment more accessible, both nutritionally to the fish, and to allow laboratory analysis of pigment levels. The thick cell wall of *Phaffia rhodozyma* may be ruptured by using chemical, biological or physical means, to release the intracellular products from the cells (Schutte, M., and Kula, M. 1990). It is important to select a method that will not damage the product that is being sought, namely astaxanthin. There are many methods of cell disruption that are used for a wide selection of organisms. These methods are listed in Table 2.10.1 .

In order to process *Phaffia rhodozyma* before using it as a nutrient and pigment source for salmonids, a cell disruption method will have to be employed which will not cause denaturing of the pigment, and which can be applied on a large scale. Many methods have been used to extract astaxanthin from *Phaffia rhodozyma*, and these will now be discussed in detail (see Table 2.10.2)

Mechanical methods can be applied on a large scale, and many different techniques have been tested on *Phaffia rhodozyma*, to allow rupturing of the thick cell wall to release the pigment. Wet milling in a high speed bead (or ball) mill, high pressure homogenisation, and high pressure extrusion have been used successfully with *Phaffia rhodozyma*. The French Press (Gaulin Press), and the homogeniser (Braun), are two of the most commonly used machines to mechanically break the cells, while leaving the astaxanthin extractable.

Table 2.10.1 Methods of Cell-Disruption

Physical Methods		Chemical Methods	Biological Methods
Non Mechanical	Mechanical		
Drying Freezing Thawing Osmotic shock Gas decompression	Sonication Wet milling Pressure extrusion High Pressure Homogenisation Impingement	Alkali Acids Solvents Detergents	Viruses Enzymatic lysis Phages Inhibition of cell wall synthesis

Table 2.10.2 Methods of Cell-Disruption used for *Phaffia rhodozyma*

Physical Methods		Chemical Methods	Biological Methods
Non Mechanical	Mechanical		
Spray -Drying Freezing Thawing	High pressure extrusion <u>Rupturing using:</u> Bead mill French Press Homogeniser eg.Braun	Acid slurry Chemical lysis using acids and alkalis Solvent Extraction	Autolysis <u>Enzymatic lysis using:</u> Funcelase SP 299 Mutanese Novozym 234

The French press (Gaulin) uses a very high pressure (8 to 10,000 psi), to rupture the cells, with ~90% breakage of 1kg of dry yeast possible in about two hours. However, this is a slow process, and small volumes of cells must be used. This is not a very practical option to use in a large scale situation (Schutte *et al.* 1990), and (Fleno, B., Christensen, I., and Larsen, R. 1988), therefore, the use of an homogeniser was also investigated very recently with Ravinder *et al.* (1995) comparing the amount of astaxanthin extracted from *Phaffia rhodozyma* and *Rhodotorula rubra*. It was found that the homogeniser had an efficiency of up to 90%, in releasing pigment from both of the

organisms. However, the efficiency rate depended on the pressure used, and the shape of the homogenisation valve. A cooling period during treatment was required, to prevent over-heating of the homogeniser. This increased the length of time that the apparatus was in use, and was considered to be a problem in terms of practicability.

Another apparatus commonly used to rupture yeast cells, is a bead (or ball) mill. A mixture of cells, suspended in the organic solvent that has been chosen for the extraction process, are ground in the bead mill (eg. Coball mill), to rupture the cells and release the astaxanthin. This process is carried out at a temperature of between 20 - 30°C. The mill contains about 15 g of glass balls, having a diameter of 0.4 mm. The bead mill is kept cooled throughout the procedure. The resulting mixture can be added directly to salmonid feeds. However, this process is very time-consuming and is not suitable for usage on a large scale (Fleno *et al.* 1988).

Since dry feed is itself extruded at high pressure, tests were carried out to determine whether this process alone would allow sufficient treatment of the yeast cells, for release of astaxanthin from the cells to take place (Fleno *et al.* 1988). A suspension of intact *Phaffia rhodozyma* cells was mixed with the feed, and extruded at high pressure. 40% of the astaxanthin was released, at conditions that were applicable commercially. High pressure gas has also been used to disrupt the yeast cells, while preserving the qualities of the proteins present. CO₂ is used for this application, as it removes any off-flavours that arise from the ruptured yeasts (Lin, H.M., Chan, E.C., Chen, C., and Chen, L.F. 1991).

Various non-mechanical methods have been used to rupture the yeast cells, including freezing and thawing, which was found to be ineffective. Grinding the yeast cells in a mortar using a pestle, did not allow the pigment to be more easily extracted. Boiling the cells in water simply caused them to clump together in a sticky paste. Treatment of these cells with 6N HCL for three minutes, rendered the astaxanthin completely extractable. However, the acid involved destroyed the astaxanthin, since carotenoids are degraded by either oxidation, rearrangement or isomerisation in acidic solution (Torregrossa, R.E., and Prevatt, W.D. 1991).

Other methods of chemical treatment have been used to treat *Phaffia rhodozyma* cells, to render the astaxanthin extractable. These include the usage of acids, alkali and solvent mixtures, yeast wall lytic enzymes and commercially available enzymes. The treatment of *Phaffia rhodozyma* cells with various acidic and alkaline solutions has been carried out, to see if this would allow the cell walls to become weaker, and facilitate easier extraction of the pigment. The treatment of yeast cells with acids, is preferred to the usage of alkali solutions.

A methylene chloride technique that was carried out on *Pichia lysis* was also tested on *Phaffia rhodozyma*. A cell suspension of ~ 80 g/l was adjusted to pH 7 with ammonium hydroxide, made up to 1% (v/v) in methylene chloride, and cultivated for 24 hours at 37°C in a sealed vessel. No breakage was induced by this treatment, or by using 3% (v/v) ethyl ether, at a pH in the range 5 to 9, and at concentrations in the range of 0.25 to 1.5 N sodium hydroxide. All attempts produced less than 5% breakage (Prevatt, W.D. 1991).

Treatment with hot acid is a standard method for hydrolysis of carbohydrate chains. While carotenoids containing epoxide groups are known to be acid labile, those lacking structures (like astaxanthin) are apparently much more resistant ; strong acidic mobile phases have been employed in chromatographic separations of astaxanthin from other pigments. Several acids were tested to see if lysis of the cell wall would occur, with the release of the pigments. Acetic, formic, sulphuric, phosphoric and hydrochloric acids were chosen to be tested (Prevatt, W. 1991). Both hydrochloric and sulphuric acid were shown to support significant breakage. Using an elevated temperature of 60°C increased the percentage breakage from 40 to 91% for sulphuric acid, and from 30 to 90% for hydrochloric acid. A total lysis time of 7 to 12 hours allowed maximum breakage of the cell wall. This study also compared the spectra of carotenoid acetone extracts from the acid lysed cells, and the bead broken cells, and found that both were similar in the region of carotenoid absorption (490 nm).

Another technique tested, was the the usage of acid lysis in combination with homogenisation, to rupture the cell walls, and allow the extraction of the pigment. The cells were first contacted with dilute sulphuric acid (0.6 to 1N) to soften the them. Using 1N sulphuric acid, followed by homogenisation (one run), almost 96% breakage of the cells occurred. The use of SP-299 Mutanese™

to "presoften" the cells, followed by homogenisation, proved ineffective with only 40% breakage being achieved (Prevatt, W.D. 1991).

In contrast to most conventional extraction procedures, which are always performed on ruptured cell material, glacial acetic acid was used to extract astaxanthin from whole, unruptured cells (Fleno *et al.* 1988). Dried whole yeast cells were used, and the extraction was carried out in the temperature range 20 to 60 °C (a temperature above the freezing point of the solvent). The extraction with glacial acetic acid allowed 70 - 90% of the pigment to be extracted from the cells. The extract also contains ~ 30 to 35% of yeast dry matter. A large volume of acid is needed for this procedure, and it would therefore not be practical to use this process on a large scale.

Johnson, E.A. (1978), used various solvent mixtures to extract astaxanthin from *Phaffia rhodozyma* cells, but found them to be ineffective. Various combinations of solvents including ether, methanol, benzene, chloroform, ethanol, toluene, ethyl ether and petroleum ether were used.

Autolysis of the yeast has been carried out using a 0.02 molar citrate buffer (at a pH of 7), and distilled water (Okagbue, R.N., and Lewis, M.J. 1984). Astaxanthin was extractable from the cells using this system. The pink colour of the cells was also preserved. This study showed that this system could be employed to render the astaxanthin available, and possibly nutritionally available for absorption, although no feeding trials were carried out. It should be pointed out however, that the pigment analysis in this study, was restricted to visual examination.

Another method employed to aid astaxanthin extraction has been patented, and involves forming an aqueous slurry of the yeast, in an aqueous solution of either hydrochloric or sulphuric acid. The slurry is heated to ~ 80 °C for between 3-6 hours, after which time it is neutralised to ~ pH 7 by using an alkaline solution, and then dried (Nelles, L.P., and Wegner, E.H. 1993). This process greatly enhances the effect of rupturing the cells mechanically, or even enzymatically, but the degradation of astaxanthin by the acid must be taken into account.

Enzymatic digestion of the cell wall using a lytic enzyme produced by *Bacillus circulans* (WL-12) has also been used as a method of cell digestion. This

method was first tested to determine if the extractibility of astaxanthin would be increased, if the lysed cells could be fed directly to salmonids as a pigment source (Johnson, E.A., Villa, T.G., Lewis, M.J., and Phaff, H.J. 1979). *Phaffia rhodozyma* was cultivated under normal conditions, the yeast cells were inactivated by heat-treatment, the pH was adjusted to 6.0, and the culture was then inoculated with the *Bacillus circulans*. The heat-treatment caused partial degradation of the astaxanthin, which is not desirable, and the adjustment of the medium pH is a little laborious. This study also discovered that the β -(1 \rightarrow 6)- and β -(1 \rightarrow 3)- glucanases were the most important in cell wall lysis.

After the initial work with *Bacillus circulans* (W1-12) had proved relatively successful, a later study looked at an alternative method to grow *Phaffia* and *Bacillus* in a mixed culture, and overcame the disadvantages that occurred with the earlier system. The *Bacillus circulans* (W1-12) cells were grown on the mature, heat-killed yeast cells, to stimulate the lytic enzymes. To avoid heat destruction of the yeast carotenoids, the two organisms in a mixed culture with glucose as the carbon source (Okagbue, R.N., and Lewis, M.J. 1983). Extractibility of astaxanthin was achieved by direct treatment of the yeast-bacterium biomass with acetone. The supernatant from the mixed culture retained yeast cell wall lytic activity, and could be recycled. The supernatant was used to treat whole cells of *Phaffia rhodozyma*, and facilitated solvent extraction of the astaxanthin. This enhanced the commercial potential of the mixed culture system.

This study prompted further work with the mixed culture system, and this system was tested using a 5L fermenter (Okagbue, R.N., and Lewis, M.J. 1985). A high inoculum of *Bacillus circulans* was needed to accelerate lytic activity, and when the bacterial inoculum was four times that of the yeast, over 80% of the total astaxanthin was extractable in 48 hours. When a mixed culture filtrate was incubated with pure cultured *Phaffia rhodozyma* cells, extractibility of astaxanthin was also achieved. A scheme incorporating a mixed culture with *Bacillus circulans* WL-12 and re-use of the culture filtrate, was proposed for the enzymatic processing of *Phaffia rhodozyma* for inclusion in animal diets, and is shown in Figure 2.10.1.

Figure 2.10.1 Proposed Scheme of Enzymatic Processing of *Phaffia rhodozyma*

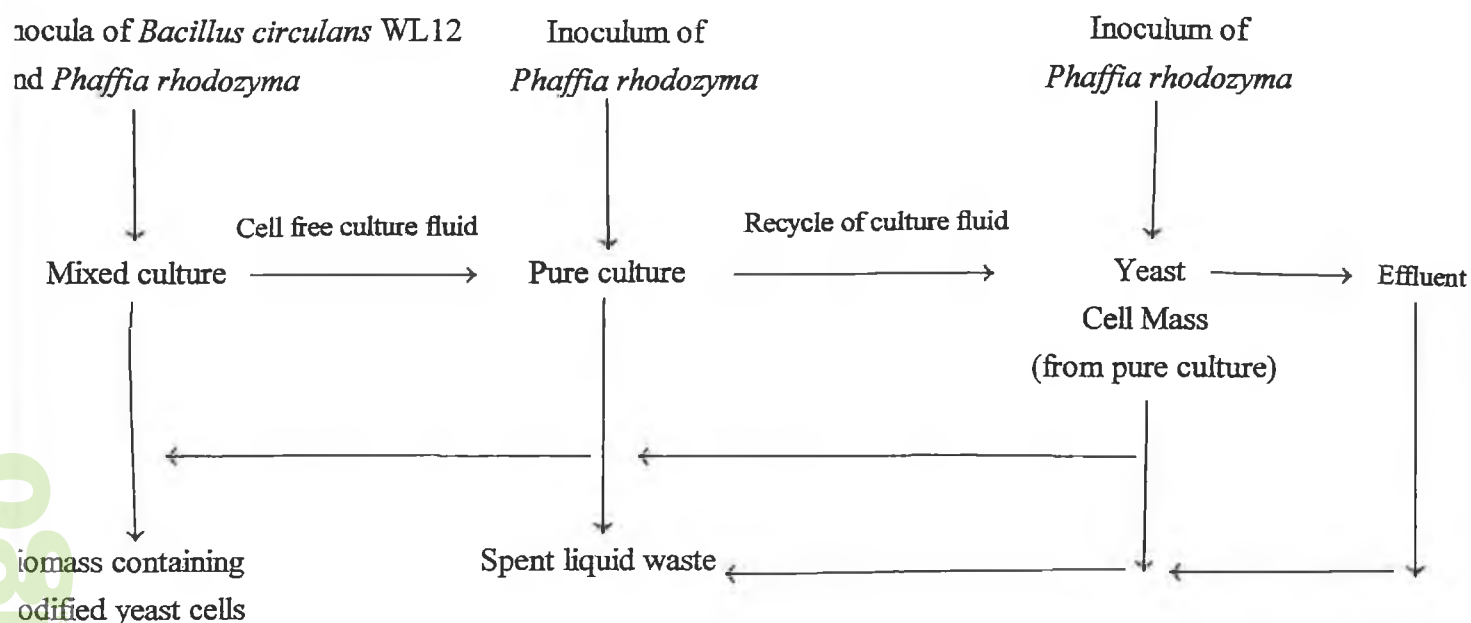

(Okagbue, R.N., and Lewis, M.J. 1985)

Carbon sources which are less expensive than glucose such as molasses, can be used in the mixed culture system (Johnson *et al.* 1979) and (Okagbue *et al.* 1983) but pH control is critical to the maintenance of good lytic activity

Other, more recent enzymatic for the extraction of astaxanthin from *Phaffia rhodozyma* cells, involves the use of several commercially available enzymes, of which the most commonly used are ; Fungelase, Novozyme 234, and SP-299 Mutanase.

Fungelase is a lytic enzyme produced by the Yakult Honsha Co. Ltd., which is water-soluble. Using this enzyme, the pigment can be extracted very

successfully from the yeast. The yeast capsule, and not the cell wall, is removed by using this enzyme (Gentles, A.S., and Haard, N.F. 1991).

Novozyme 234 is another multi-component enzyme product isolated from *Trichoderma harzianum*. This enzyme modifies the cell wall so that astaxanthin extraction is possible. SP-299 Mutanase is another enzyme product isolated from *Trichoderma* that modifies the cell wall to release the astaxanthin. Both of these enzymes are sensitive to temperature, and pH, and work best in a specific range, for example, Novozyme 234 works in a pH range of 4.5 to 5.0 and a temperature range of between 21-24°C, using 0.2 to 10 units of the enzyme per 100g/l. SP-299 Mutanase and Novozyme 234 are both produced by the Nova Bioindustrial Group, Denmark. Both of these enzymes work best when contacted with *Phaffia rhodozyma* cells that have been in a log phase of growth. The incubation time for both of these enzymes varies, however, a contact time of about 24 hours usually provides maximum digestion (Torregrossa, R.E., and Prevatt, W.D. 1991).

Other lytic enzymes (also produced by Nova Bioindustries), have also been tested on *Phaffia rhodozyma* cells. These include;

- Novo Viscozyme,
- Novo Gamanase,
- Novo Ceremix,
- and -Novo Cytoclase.

These enzymes have proven to be less than successful, at digesting the yeast cell wall (Torregrossa *et al.* 1991).

Feeding trials have been carried out with fish, using *Phaffia rhodozyma* cells that were treated four different ways prior to inclusion in the rations. The four methods tested were ; mechanical milling, enzyme treatment, spray-drying, and chemical extraction of the pigments (Gentles *at al.* 1991). All of the methods used, resulted in excellent colouration and pigmentation of the muscle tissues, and skin of the fish. The spray-dried cells pigmented the fish which was surprising, since they had not undergone any specific disruption method. However, fish fed the diet containing these cells showed a higher rate of pigmentation, than the fish fed the diet containing the extracted carotenoid. It

would appear therefore, that yeast digestibility is improved by the spray-drying process. All four diets used, gave excellent pigmentation within four weeks.

2.10.5 Development of Novel Strains of *Phaffia rhodozyma*

The availability of *Phaffia rhodozyma* as an astaxanthin source in the aquaculture industry, is limited by the carotenoid content of the natural isolate. One way to increase astaxanthin production, is to genetically manipulate the astaxanthin biosynthetic pathway, and this has been accomplished using various techniques. It is thought that the rate of astaxanthin biosynthesis is genetically controlled by the yeast in such a way that astaxanthin synthesis proceeds at a limited rate, and that this genetic limitation can be relieved through the elimination of the negative regulators the activation of the positive regulators, and duplication of structural genes using chemical and irradiative mutagenesis, as well as genetic recombination. Screening methods have also been developed to detect the astaxanthin overproducers that occur as a result of the genetic manipulation (An *et al.* 1989).

Mutagenesis is one of the most common methods used to produce astaxanthin over-producers. Mutagenesis can be accomplished by using physical means, such as Ultra Violet (UV) light or X-rays, or by the use of chemical agents. Many chemical agents have been used with *Phaffia rhodozyma*, including; N-methyl-N'-Nitro-N-Nitrosoguanidine (NTG), Ethyl methanesulfonate (EMS), 5-Bromouracil (5BU), Ethidium Bromide (EtBr), 2-Aminopurine (2AP), and Acridine Orange (AO).

The two most commonly used agents are NTG (Prevatt, W.D., Dickson, T.D., Vineyard, K.M., Harris, R.L., and Just, D.K 1991), (Fang, T.J., and Cheng, Y.S. 1993), An, G.H., Schumann, D.B., and Johnson, E.A. 1989), (Evans, C.T., Adams, D., and Wisdom, R.A. 1990), and (Meyer, P.S., Wingfield, B.D., and du Preez, J.C. 1994), and EMS (Adrio, J.L., Viegas, M., Casqueiro, J., Lopez, M., and Fernandez, C. 1993), (Calo, P., Valasquez, J.B., Sierio, C., Blanco, P., Longo, E., and Villa, T. 1995), and (Lyons, T.P., and Jaques, K. 1990).

Astaxanthin levels of over 9,000 $\mu\text{g/g}$ yeast have been reported using several rounds of mutagenesis (Prevatt, W.D. 1991). However, high producing mutants have been shown to be unstable, reverting back to the parent whenever

possible (Johnson *et al.* 1991). Stabilisation has been attempted by streaking the high producers onto agar, up to six times (Villadsen, I.S. 1992).

A non-reverting strain was produced by chance, by Johnson *et al.* 1993). While treating *Phaffia rhodozyma* with several inhibitors of electron transport, including Antimycin A, and sodium cyanide, strange colonies were seen on plates, with an unusual morphology characterised by a non-pigmented lower smooth surface, which developed into a highly pigmented vertical papillae. One of these papillae was found to be an astaxanthin over-producer, producing 3 to 6 times more astaxanthin than the natural isolate. Further study found that when a naturally occurring, or mutated strain was grown in a medium containing a cytochrome B inhibitor, an antibiotic, or a terpenoid pathway inhibitor, a non reverting strain was produced.

If *Phaffia rhodozyma* is also cultured in the presence of a metabolic pathway inhibitor (particularly a main respiratory pathway inhibitor), or in the presence of any influence that triggers a secondary pathway the same thing happens (Johnson *et al.* 1991).

Mutant strains have also been isolated from ultra-violet (UV) light mutagenesis. The mutants produced by this method usually have lower astaxanthin contents, and a paler colour than their parents. When NTG mutagenesis is used with UV mutagenesis, up to 8025 µg/g of astxanthin was obtained from the resulting mutants (Prevatt *et al.* 1991). The researchers in this study suggested that combining mutagenesis with cell fusion, was more productive than using either cell fusion or mutagenesis on it's own. They suggested the combination of mutagenesis and cell fusion in the following cycle (figure 2.10.5), was the most productive method to produce high-producing strains of *Phaffia rhodozyma* (Prevatt, W.D., Dickson, T.D., Vineyard, K.M., Harris, R.L., and Just, P.K. 1991).

Figure 2.10.5 Mutagenesis and Cell Fusion Cycle

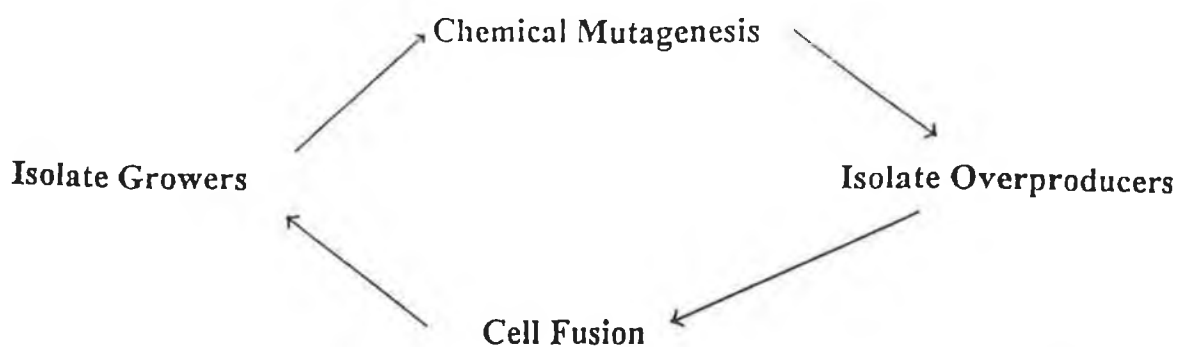

Prevatt *et al.* 1991)

A new mutation strategy was recently developed, to produce mutants of *Phaffia rhodozyma*. This involved the γ -irradiation of the yeast cells, followed by a selective enzymatic enrichment step (Palagyi, Z., Nagy, A., Vagvolgyi, C., and Ferenczy, L. 1995). The selective enrichment procedure needed to be carried out to isolate the mutants, as they could not be demonstrated directly after the mutagen treatment. γ -irradiation resulted in mutants being produced that were drug-resistant, unlike the mutants that are produced using EMS and NTG mutagenesis, where 40% of the mutants produced are adenine requiring (Adrio, J.L., Veiga, M., Casqueiro, L., Lopez, M., and Fernandez, C. 1993).

The carotenoid, 3-hydroxy-3,4'-didehydro- β , ψ -carotene-4-one, or HDCO, was first identified in *Phaffia rhodozyma* in 1976. After mutagenesis, some strains contain much higher quantities of HDCO compared with their astaxanthin content (Lewis *et al.* 1990). Lewis *et al.* (1990), found that the amount of HDCO as compared to astaxanthin increased due to mutagenesis. HDCO levels were seen to increase from 4% to 8%. High amounts of HDCO are unacceptable as additions to animal feed. Strains of *Phaffia rhodozyma* were obtained with high astaxanthin and a low percentage of HDCO, using a patented system (DeBoer *et al.* 1993). These strains were obtained by NTG and EMS mutagenesis, as well as UV irradiation and other nucleotide base analogues. Other strains that maintain high astaxanthin and biomass levels, have also been isolated (Evans, C.T., Adams, D., and Wisdom, R.A. 1991).

The potential for further progress in the improvement of astaxanthin content in *Phaffia rhodozyma* by conventional mutagenic techniques, appears to be

limited (Johnson *et al.* (1991)). This is because microorganisms possess tight regulatory controls over the biosynthesis of their cellular components, so that they tend not to overproduce unnecessary cellular constituents. Since the biosynthesis of a pigment such as astaxanthin appears to be tightly regulated in any given strain of yeast cells, the chances of producing a viable inheritable genetic alteration, to produce colonies capable of increased astaxanthin production, by using undirect mutagenesis, is very low.

The success of mutagenesis depends on the use of proper screening techniques. Fortunately, the colour of astaxanthin is orange/red, and mutants can be screened visually. The basis of most screening techniques, is to find conditions where the mutated cells grow at a much faster rate than the unmutated cells (Johnson *et al.* 1991).

Carotenoids are known to quench radicals (Krinsky, N.I. 1989), so one approach that has been tested, involves mixing the *Phaffia rhodozyma* cells with albino mutant cells, followed by exposure to light. The culture gradually becomes enriched with astaxanthin synthesising cells (Johnson *et al.* 1991).

A variation of this technique, is the use of β -Ionone to select for over-producing mutants. β -Ionone is an end ring analog of β -carotene. Although β -Ionone stimulates carotenogenesis in *Phycomyces blakesleeanus* (Mackinney, G., Nakayama, T., Chichester, C.O., and Biss, C.D. 1953), and *Blakeslea trispora* (Ninet, L., Renaut, J., and Tissier, R. 1969), there is little stimulation of β -carotene production in *Phaffia rhodozyma*. β -Ionone inhibits xanthophyll formation, by blocking the astaxanthin at the β -carotene level. Astaxanthin over-producing mutants are easily spotted on β -Ionone containing yeast malt agar plates. As the concentration of β -Ionone is increased, the colour of the mutants changes from pink/red, to yellow/yellow-white. Because of the low oxygen level, production of oxygenated carotenoids is inhibited when *Phaffia rhodozyma* grows on plates, and the ability of higher producers to yield astaxanthin is not fully expressed. This technique was very useful in combatting this problem, since the over-producing mutants were easily spotted on the plates.

An alternative cell screening method that has been used is Flow Cytometry Cell Sorting, or FCCS (Johnson *et al.* 1991). This technique was first developed in 1934, to count microscopic cells, and Coulter developed the Coulter Counter,

that counted and analysed cell size. Contemporary flow cytometers simultaneously analyse cells for forward scatter (related to size), side scatter (related to cell granularity), and for fluorescence admissions at three to four different wavelengths. Most modern instruments can analyse and sort cells at the speed of 4,000 to 10,000 cells per second. To be used for practical screening in strain development, the flow cytometer must be able to detect specific wavelengths of fluorescence, to avoid quenching by autofluorescent metabolites in the cells (Johnson *et al.* 1991). This method was successfully used by Johnson *et al.* (1991), to isolate hyper-producing mutants of *Phaffia rhodozyma*. Autofluorescence of *Phaffia rhodozyma* carotenoids is low, but conditions were developed which allowed the detection of single cells, with enhanced carotenoid autofluorescence.

This method was found to be effective for screening purposes, and has a potential for more general use. Future developments in FCCS, such as optimisation of sorting conditions, and single cell deposition, could further improve this method, and enlarge its range of application.

Another genetic technique that has been utilised to create astaxanthin over-producers, has been the spheroplast technique (Prevatt, W.D. 1992), (Chun, S.B., Chin, J.E., Bai, S., and An, G.H. 1992), and (Santopietro, L.M., Spencer, J.F.T., Spencer, D.M., and Sinenz, F. 1995). This technique is also called cell fusion, or protoplast fusion. It involves the gentle removal of the cell walls, by enzymatic means, followed by mixing of the delicate protoplasts. This mixing occurs in a high osmotic medium, with the cell membranes being fused using polyethylene glycol (PEG). Cellular contents can then mix, and the fusants are incubated in a high osmotic agar, to allow the cell walls to regenerate, and to prevent the spheroplasts from rupturing. The stable hybrids are then selected, with novel hybrids being identified by a combinations of various traits, characteristic of each parent. Only stable hybrids represent new strains.

Cell fusion of *Phaffia rhodozyma* strains by this technique, can provide a process for combining vigorous growth characteristics with high astaxanthin producing strains, many of whom have poor growth characteristics (Prevatt, W.D. 1992). Care must be taken when removing the cell walls, to retain the viability of at least a portion of the spheroplasts formed.

A protocol for the preparation and regeneration of spheroplasts from *Phaffia rhodozyma* has recently been developed, with 70% conversion being obtained after 25 minutes at 30°C, or 70% conversion being obtained after 50 minutes at 22°C (Santopietro *et al.* 1995). The normal fusion technique was carried out, with one exception. The cells were first "pre-treated" in various buffer solutions (0.1M tris-HCL, 1M KCL, and 0.01M EDTA). The pre-treatment of the cells in the KCL solution, greatly increased the stability of the spheroplasts formed. Stable hybrids have been formed using cell fusion, that can produce > 2000 µg carotenoid / g of yeast, and that are auxotrophic for leucine, tryptophan, methionine, or arginine (Chun *et al.* 1992). Strains have also been obtained, with astaxanthin contents of 8568 µg / l astaxanthin per litre of fermentation broth, or with an astaxanthin content in the range of 1430 µg / g to 1660 µg / g astaxanthin per g dry weight of cells. The cell hybrids produced are very stable (Prevatt, W.D. 1992). This cell fusion technique is preferable to the mutation selection previously used (Chun *et al.* 1992).

In the last three to four years there has been a great deal of genetic research carried out on *Phaffia rhodozyma* with regard to studying the DNA profile of the yeast, in order to determine the genes that are responsible for astaxanthin production. This information would be very useful in understanding the mechanisms by which genetic regulation of astaxanthin production in *Phaffia rhodozyma* is achieved.

Genetic analysis of astaxanthin over-producing mutants of *Phaffia rhodozyma* was carried out using a technique called "Randomly Amplified Polymorphic DNA's", or RAPDs, which was used as a quicker alternative to the RFLP technique (Meyer, P.S., Wingfield, B.P., and du Preez, S. 1994). Simple and reproducible fingerprints from a naturally occurring *Phaffia rhodozyma* strain, as well as from astaxanthin over-producing mutants were obtained, using a single arbitrary primer obtained with PCR. Between 3-5 major DNA fragments were produced. They ranged in size from 0.7 to 2.0 kilobase pairs (kb). Some bands were present in all of the strains tested, while others were only observed in individual mutants. It was therefore concluded that a single primer of arbitrary sequence could be used to amplify genomic DNA segments from *Phaffia rhodozyma*. It was also determined that RAPDs a powerful and easy to interpret technique, that could be useful in mapping the genome of *Phaffia rhodozyma*.

The growing interest in commercial astaxanthin production, has necessitated the DNA finger-printing of astaxanthin over-producing mutants for strain identification. DNA finger-printing could also assist in quality control, to ensure that the final culture has a pattern identical to the original strain used. As stated previously, RAPDs was used successfully to detect differences induced by mutagenesis, in astaxanthin over-producing mutants.

A recently described electrophoretic karyotype of *Phaffia rhodozyma* was obtained by embedding a bulk amount of protoplasts into agarose plugs (Nagy, A., Garamszegi, N., Vagvolgyi, C., and Ferenczy, L. 1995). A search for a more simplified procedure did not reveal conditions under which chromosomal DNA could be liberated from intact *Phaffia rhodozyma* cells.

More recently, a simple method to obtain chromosomal DNA has been developed, with Field Alternation Gel Electrophoresis Analysis being carried out on the obtained chromosomal DNA (Nagy, A., Vagvolgyi, C., and Ferenczy, L. 1995). A simple method for protoplast formation allowed efficient and simple sample preparation. The technique was similar to that discussed previously (Santopietro *et al.* 1995), except that in this case, after "pre-treatment" of the cells, which was then followed by enzymatic treatment, the cells were further treated by incubation at 50°C for 48 hours, in a 1% sodiumlauroylsarcosine and a 1mg / 1 proteinase K solution, before being suspended in an osmotic solution. The separation of chromosomal DNA molecules, resulted in clearly resolved electrophoretic karyotypes. The chromosomal patterns obtained were identical, irrespective of whether pre-formed or in-situ protoplasts were applied.

A major advantage of this technique, is that it can successfully be carried out, even if the amount of yeast cells available for analysis is limited. This technique also allows numerous samples to be handled simultaneously, to allow karyotyping of a large number of strains to take place.

Gist-Brocades published a patent in 1994, that disclosed a transformed *Phaffia rhodozyma* strain, and that also disclosed specific vectors for transforming the yeast. The use of marker genes in *Phaffia rhodozyma* was also disclosed (Van Ooyen, A.J. 1994). Specific strains of *Phaffia rhodozyma* were transformed, and over-expression of desired genes in the yeast was also achieved.

One of the methods used to transform the *Phaffia rhodozyma* strains, involved growing the cells to the exponential phase, preparing protoplasts from these cells, adding a vector (containing a desired gene cloned downstream from a promoter that is active in *Phaffia*), plating the protoplasts on a selective regeneration medium, and selecting the transformed *Phaffia rhodozyma* strains. Another method used for transforming the *Phaffia rhodozyma* strains, is the LiAc (lithium acetate) method. This method involves growing the yeast cells to the desired density, harvesting the cells, incubating the cells with transforming DNA in the presence of lithium acetate, and spreading the resulting mixture on selective plates (Van Ooyen, A.J. 1994). An isolated DNA fragment, encoding the acting promoter, was also obtained from *Phaffia rhodozyma*.

One of the most exciting developments in the area of genetic engineering, with relation to *Phaffia rhodozyma*, has been the recent plasmidic transformation of the organism (Adrio, J.L., and Viega, M. 1995). The genetic transformation of *Phaffia rhodozyma* was carried out using the cloning vector pGH-1. This plasmid can replicate autonomously in the yeast. This breakthrough has opened the door to the possible cloning of genes involved in the astaxanthin biosynthetic pathway, which could result in improved pigment production by the yeast. However, further studies would need to be carried out to improve the transformation efficiency of the yeast.

The recent genetic studies that have been carried out, have brought us closer to understanding the genetic regulatory mechanisms employed in astaxanthin production by *Phaffia rhodozyma*. The genetic transformation of *Phaffia rhodozyma* strains is the first step in a possible production of strains of the yeast, that could be genetically programmed to produce very high levels of astaxanthin, and other carotenoids. This could lead to the yeast being successfully cultivated in an industrial situation, with *Phaffia rhodozyma* possibly becoming the main industrially produced "natural source" of astaxanthin.

2.10.6 Commercialisation of Astaxanthin Production by *Phaffia rhodozyma*

The commercial availability of *Phaffia rhodozyma* as an astaxanthin source, is dependant on the development of a commercially viable processing technique.

Continuous fermentation, where some of the spent medium is replaced with new medium, has often been employed in yeast production facilities to keep costs low. However, this method is not thought to be suitable for the production of astaxanthin by *Phaffia rhodozyma*, since continuous growth of the cells is needed, and astaxanthin continues to be produced by the organism after growth has ceased. Since a longer fermentation time is needed than is usual with most commercial yeast production, stricter sterile conditions are needed, than for fed-batch or batch systems. The temperature of growth for *Phaffia rhodozyma* must be maintained in the region of 20-22°C, and cooling of the culture equipment must therefore be provided.

A recent study assessed the potential for the use of continuous culture, the low specific growth rate of the yeast, and the low astaxanthin levels achieved (Meyer, P.S., and du Preez, J.C. 1994). It was suggested that the use of continuous culture to grow the organism, was not appropriate. Another disadvantage to this system was the accumulation of glucose that occurred when dilution rates above 0.07 hr⁻¹ were used, and this had a detrimental effect on the levels of astaxanthin produced. It was therefore concluded that a fed-batch system of culture for the production of astaxanthin from *Phaffia rhodozyma*, would be most effective.

Astaxanthin has been made commercially available only recently, by Gist-Brocades, in The Netherlands (Prevatt, W.D. 1994). *Phaffia rhodozyma* is cultured, with astaxanthin being produced by the yeast. At the end of fermentation the production strain is inactivated by heat-treatment, and the resulting "mash" is conserved by cooling, then reducing the pH. This mixture is centrifuged to concentrate it, the concentrate is collected and spray-dried to yield an agglomerated powder; the final product. This is then stored under cool conditions.

One of the most important aspects of the commercial production of astaxanthin from *Phaffia rhodozyma*, is the need for a stabilisation method. *Phaffia rhodozyma* suspensions have low astaxanthin stability, and are impractical to transport. Before packaging can take place, a drying step, followed by stabilisation is needed. The use of the spray-drying method to stabilise the yeast is the best available method since the yeast is only exposed to high temperatures for a short period of time. Before or after the drying process, an antioxidant must be added.

This commercial product is called "Natupink", but it is currently not for sale in the U.S., or Europe, but as registration is pending, it should be available in the near future.

Chapter Three

Materials and Methods

3.0 Materials and Methods.

3.1 Introduction

The majority of the fermentations carried out in this study, were batch fermentations performed using the shake flask system of culture. For the purposes of the glucose supplementation experiments, fed-batch fermentations were carried out also using the shake flask system.

The experiments carried out to compare biomass and pigment production by *Phaffia rhodozyma* using the parent strain, and a mutant strain of the yeast, were carried out as batch fermentations using a two litre laboratory fermenter.

The shake flask system of culture was utilised extensively in this project mainly for the following reasons:

- To obtain a better understanding of the optimum conditions under which *Phaffia rhodozyma* produces astaxanthin;
- To facilitate the scale - up process to a larger volume fermentation system;
- and to use the knowledge previously gained, to allow the scaled up fermentation system to operate under optimum conditions.

To consider the data generated by experimental means, it is necessary to fully know and understand the methodology and specific equipment utilised. The equipment and analytical techniques used in the preparation of this thesis will now be fully described. The laboratory equipment, and how it was used in maintaining and culturing the yeast *Phaffia rhodozyma* will be fully explained. All of the analytical techniques employed in the determination of the growth and pigmentation of this organism, will also be fully described.

3.2 Shake Flask Culture System

Using this system, the yeast cultures were grown in 250 ml erlenmeyer flasks, containing 100 mls of growth medium (unless otherwise stated). The cultures were incubated at 20°C using an orbital shaker (New Brunswick Scientific Co.)

at a speed of 220 rpm. All shake flask experiments were performed in triplicate, over a ten day period.

3.2.1 Inoculum Preparation for Shake Flask Cultures

All of the shake flask cultures were inoculated with a 10% (vol/vol) inoculum from a starter culture. The starter culture used for any given experiment was grown for 72 hours under the same conditions and in the same growth medium as was being used in that experiment. All of the starter cultures were inoculated using a loopful of *Phaffia rhodozyma* from either a plate or slant culture. The starter cultures were removed from the shaker table at 72 hours, when the yeast cells were in the exponential phase of growth.

3.2.2 pH Control

All the growth media used were buffered at pH 5.0 with 0.1 M Potassium Hydrogen Phthalate buffer (30 g of Potassium hydrogen phthalate crystals dissolved in 1l distilled water). Every 24 hours samples were taken from the flask cultures, and the pH measured using a portable pH meter. If required, the pH of the cultures was re-adjusted to fall within the required pH range of 4.0 to 4.5, using sterile potassium hydrogen phthalate buffer.

3.2.3 Sterilisation Procedure

Shake flasks containing the growth media were autoclaved at a temperature of 121°C at 15 psi for 15 minutes. Before sterilisation the components of the growth medium were checked to ensure that neither depreciation nor precipitation of any heat labile ingredients would occur.

3.2.4 Sampling Procedure

As stated previously all of the shake flask experiments were carried out over a ten day period. A total of thirty flasks were used in each experiment, as one flask (in triplicate) was used per each 24 hour time period. Every 24 hours, three flasks were removed from the shaker table. Samples were taken from various flasks at random times during the experiment. The pH and turbidity of these samples was measured, to allow the culture conditions to be checked during the course of the experiments.

3.3 Laboratory Fermenter

The fermentation equipment used was a bench sized system, designed by the manufacturer to offer controlled growth conditions for cells. The 2L fermenter used was a 500 Series III two litre fermenter (LH Fermentation Ltd., Bucks., England), with temperature, aeration, pH and agitation control. The layout of these modules is shown in Figure 3.3.1 . For power supply, the modules are all interconnected. The actual laboratory equipment used is shown in Figure 3.3.2

Figure 3.3.1 General Layout of Fermentation equipment Showing the Module Power Connections

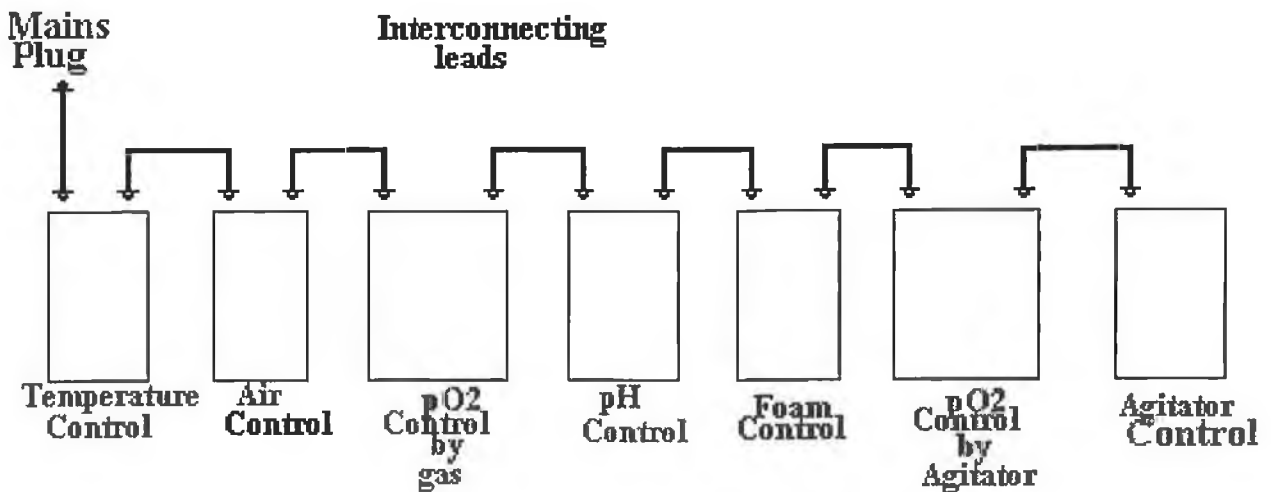
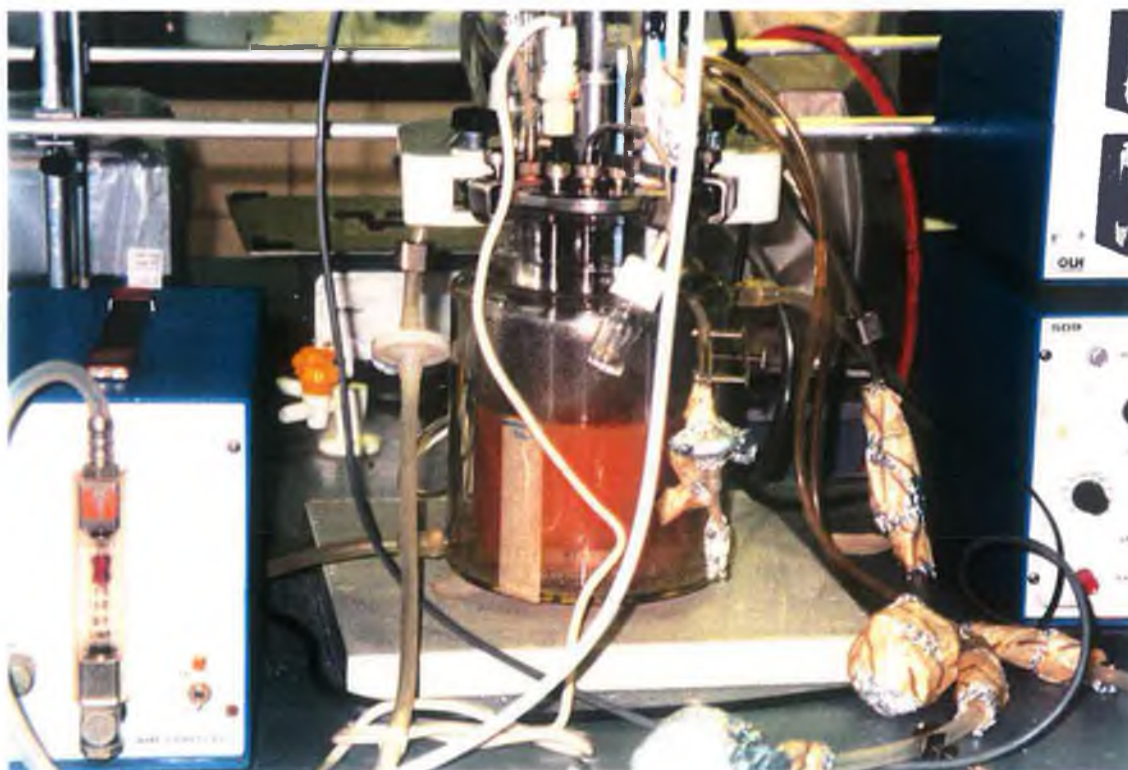
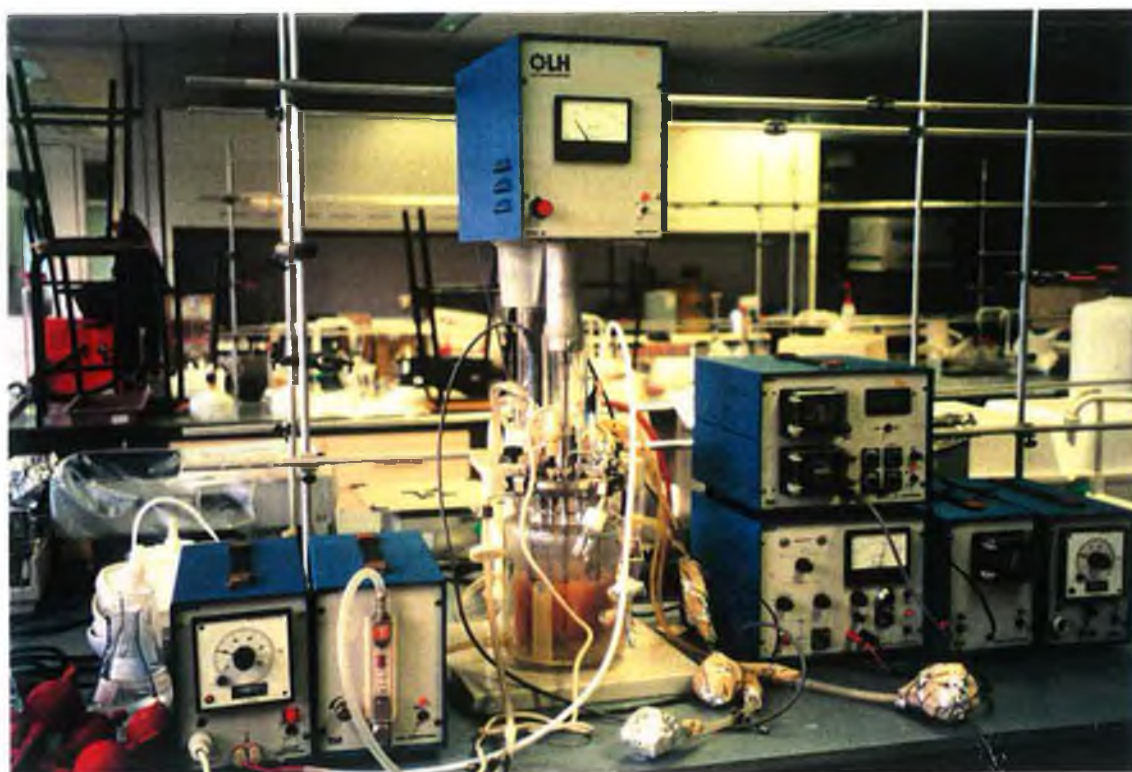

Figure 3.3.2 Fermentation Equipment Used



3.3.1 Culture Vessel

Connections from each of the modules to the culture vessel, are made via fittings in the vessel top plate as shown in Figure 3.3.3

Figure 3.3.3 Fittings to the Top Plate of Culture Vessel

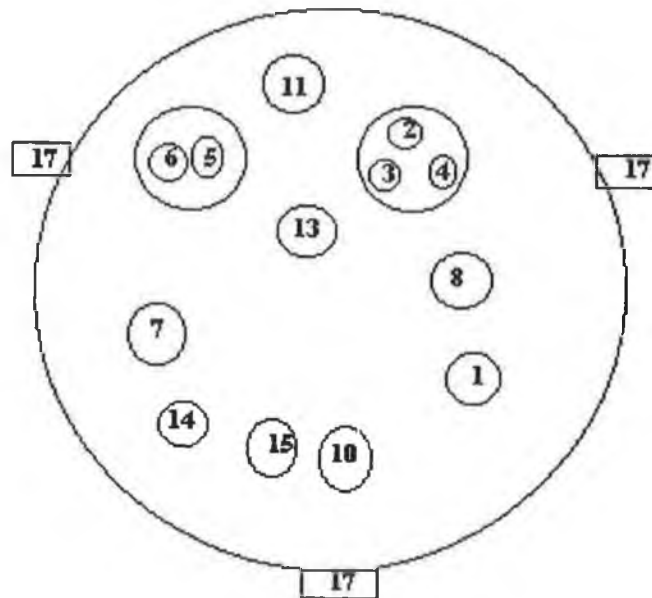

Ports Used:

1. Air out
2. Acid Addition Port
3. Alkali Addition Port
4. Antifoam Addition Port
5. Water Inlet
6. Water Outlet
7. pH Electrode Port
8. O₂ Electrode Port
10. Heater Port
11. Sample Port
13. Inoculation Port
14. Temperature Sensor Port
15. Bearing House and Air In
17. Top Plate Clamp and Screws

3.3.2 pH Control

The control of pH in the culture vessel is critical. The pH of the culture should be kept between 4.0 to 5.0 . pH control is achieved using a pH electrode which is connected to the pH control module. Two peristaltic pumps, a lower peristaltic pump (the alkali addition line) and an upper peristaltic pump (the acid addition line) adjust the pH to the required value.

The pH electrode used with this equipment is a Pye Ingold combined pH electrode type 465, which is inserted into the culture vessel. On completion of a culture run, the electrode should be checked for signs of mechanical damage. The electrode should then be rinsed with distilled water to remove any excess broth. When not in use the electrode is stored with its measuring tip immersed in a 3M KCL solution.

The reagents chosen for pH control were 1M HCL and 1M NaOH. The length of tubing (108 mm) used for the peristaltic pump is critical to the maintenance of the correct tension. If the length is too short the tubing will split, and if it is too long the liquid in the tubing will tend to creep past the pump head. The acid and alkali reservoirs are placed as near as possible to the heights of the peristaltic pumps, to avoid draining the reservoirs if a leak occurs in the system.

3.3.3 Aeration Control

Aeration in the culture fluid is kept controlled using a galvanic oxygen electrode that is connected to the aeration control module. This module works in tandem with an air flow module, so that when the oxygen tension falls below a set value the air pump will switch on, and pump air into the culture fluid. When the oxygen tension rises above a set value, the air pump will then switch off.

The oxygen electrodes used with this fermenter, and other kinds of bioculture equipment, have been developed specifically for measuring the pO_2 (dissolved oxygen). The type of oxygen electrode used with this fermenter is a type G2 sterilisable electrode, which is inserted into the culture vessel. The electrode is unaffected by the presence of microorganisms, and can be repeatedly sterilised by autoclaving up to a temperature of 130°C.

3.3.4 Temperature Control

The temperature of the culture can be controlled in two ways by using a temperature sensor and heater, that are inserted into the culture vessel and connected to the control module. A cold water finger is used with the above, to maintain the temperature as close to the ambient as possible. The temperature control module must not be operated unless the end of the heater is immersed in at least 40 mm of either media or distilled water.

If the temperature used throughout the experimental work is close to the ambient, the cold finger is used with the gas outlet condenser to maintain the set temperature, with cold water being run through the condenser. If the set temperature needed is below the ambient the cooling finger can be bypassed, as was the case with this experimental work. The required temperature was achieved by using a fast flow rate of water through the condenser. A thermometer was inserted into the culture vessel, to allow quick checks to be made on the temperature of the culture fluid.

3.3.5 Agitation and Stirrer Control

Agitation is carried out using a magnetic drive stirrer. Stirring should only be carried out with fluid in the culture vessel, which acts as a lubricant. The bearing should also be wet before stirring commences.

3.3.6 Foam Control

To control the foam that is generated by the aerobic growth of *Phaffia rhodozyma*, antifoam is used to ensure that the foam can be controlled - thus preventing any inhibition of growth. Dow Corning FG-10 was found to be very effective in suppressing foam. The antifoam was sterilised by autoclaving, and was injected through the antifoam addition port as required.

3.3.7 Sterilisation Procedure

The most convenient method of sterilisation is by moist heat at pressure i.e. autoclaving. The fermenter vessel, all of the tubing and fittings and reservoirs are made to specification for heating to, and maintaining a temperature of 121°C. The glucose in the growth medium cannot be autoclaved as it is not

heat stable. The glucose was prepared separately to the rest of the nutrient medium, filter sterilised then added to the culture vessel, which had been autoclaved with the other heat stable fraction of the medium inside. The acid and alkali are also not autoclaved. A volume (200 mls) of distilled water is autoclaved and the chosen concentrated acid or alkali is added. The length of time the culture vessel is sterilised in the autoclave is decided upon according to the volume of medium present in the vessel, at the beginning of the culture run. In this case, the apparatus was autoclaved for 30 minutes at 121°C, as 1L of growth medium was used in the culture vessel.

3.3.8 Sampling Procedure

Samples are taken from the culture vessel at regular intervals to allow growth and pigment production to be measured. Regular sampling is also advised to check for contamination. Sampling was carried out in the sample head, according to the procedure detailed in the instruction manual. The sample bottles were autoclaved at the start of each run, to last throughout the duration of the culture run. Two samples were taken at regular sampling points throughout the run, to provide ample sample for analysis.

3.3.9 Inoculum Preparation for Fermenter

It is not feasible to inoculate the fermenter directly using a loop from a starter plate/slant culture, given the volume of the vessel. A shake flask culture is therefore grown to provide an inoculum for the fermenter. A 250 ml conical flask containing 100 mls of sterile medium was used for this purpose. The glucose was separately filter sterilised, then added aseptically to the sterile medium which had been autoclaved. The flasks were then inoculated with a loopful of *Phaffia rhodozyma* from either a plate or slant culture, and incubated on an orbital shaker for 72 hours at 20°C, at a speed of 200 rpm. The temperature of incubation and the pH of the medium were the same as those chosen for the fermenter.

3.4 Culture Conditions and Techniques

The correct maintenance of any pure cultures used in experimental work is vital to ensure that a viable source of the organism is available at all times

throughout the project, and to ensure that the purity of the strain is maintained at all times.

3.4.1 Maintenance of *Phaffia rhodozyma*

Two strains of *Phaffia rhodozyma* were used throughout this project. The parent strain of the yeast was obtained from the National Collection of Yeast Cultures NCYC 874 (UCD 67-210, CBS 5905, ATCC 24202). A mutant strain of the yeast was obtained from a collection at Phillips Petroleum Company, Oklahoma, U.S.A., which have been deposited at the Northern Regional Research Laboratory at the U.S. Department of Agriculture, in Peoria, Illinois. The strain type used (NRRL-Y-18734) was constructed from a parent strain type (UCD 67-210, ATCC 24202) using a combination of nitrosoguanidine, ethylmethane sulphonate and 2-aminopurine mutagenesis, with spheroplast fusion to stabilise growth characteristics.

The cultures were freeze-dried in ampoules in liquid nitrogen at -180°C . The freeze-dried cultures were reconstituted with sterile Difco Yeast Malt Broth (0.3% yeast extract, 0.3% malt extract, 0.5% peptone and 1% glucose), with the pH adjusted to 5.0 using potassium hydrogen phthalate buffer, and then streaked onto sterile plates and slants of a Yeast Malt Broth (Difco Laboratories, Michigan, U.S.A.) and bacteriological agar mix (Bacto Bacteriological Agar, No.3, clear), with the pH adjusted to 5.0. All the plate and slant cultures were incubated at 21°C for 72 hours, then stored at 4°C . After slants and plates had been prepared six times from the original, a new ampoule was opened and streaked onto new plates and slants. Every six to eight weeks, new slants and plates were prepared from the 'original' plate and slant cultures.

3.4.2 Preparation of Media

Initial research carried out using shake flask cultures, involved the investigation of astaxanthin and biomass production by *Phaffia rhodozyma* in various media, to determine which supported the best growth and pigmentation. The effect of two concentrations of glucose on growth and pigment production by the yeast was investigated. Glucose was added to the growth medium after 120 hours, to determine if the addition of fresh substrate would have an effect on biomass or pigment production by the yeast.

3.4.2.1 Comparison of Various Growth Media

Biomass and pigment production by *Phaffia rhodozyma* in four different growth media was investigated. The four media chosen were:

- Difco Yeast Malt Broth (YMB);
- Johnson Lewis Mineral Salts Medium (MSM);
- Rich Assay Growth Medium (RAGM);
- Yeast Malt Broth Substitute (YS).

Yeast Malt Broth is the commercial medium available for culturing *Phaffia rhodozyma*. This growth medium contains the ingredients shown in Table 3.4.2.1.1 .

Table 3.4.2.1.1 Composition of Yeast Malt Broth Medium

Concentration (g/l)	
10 g/l	Glucose
5 g/l	Peptone
3 g/l	Yeast Extract
3 g/l	Malt Extract

The Johnson Lewis Mineral Salts Medium contains the ingredients shown in Table 3.4.2.1.2 .

Table 3.4.2.1.2 Composition of Mineral Salts Medium

Concentration (g/l)	
10 g/l	Glucose
2 g/l	Yeast Extract
1 g/l	KH_2PO_4
1 g/l	$(\text{NH}_4)_2(\text{SO}_4)$
0.5 g/l	MgSO_4
0.1 g/l	$\text{CaCl}_2 \cdot 7\text{H}_2\text{O}$

A Rich Assay Growth Medium was the third medium chosen for culturing the yeast. This complex medium contained many different ingredients, which are listed in Table 3.4.2.1.3 .

Table 3.4.2.1.3 Composition of Rich Assay Growth Medium

Concentration (g/l)	
15 g/l	Glucose
3 g/l	Malt Extract
3 g/l	Peptone
3 g/l	Yeast Extract

The final medium chosen for culturing the yeast was a modified or substitute Yeast Malt Broth. This was prepared using the ingredients listed in Table 3.4.2.1.4

Table 3.4.2.1.4 Composition of Substitute Yeast Malt Broth Medium

Concentration (g/l)	
15 g/l	Glucose
3 g/l	Malt Extract
3 g/l	Peptone
3 g/l	Yeast Extract

All of the various media used were prepared in the same way. The heat stable fraction of the medium was first prepared and the pH was then adjusted to 5.0 using the Potassium Hydrogen Phthalate buffer, followed by autoclaving at 121°C for 15 minutes. The glucose was filter sterilised and then aseptically added to the autoclaved, heat stable fraction of the medium. The various media were all prepared per litre of distilled water.

3.4.2.2 Comparison of Carbon Concentrations

In later experiments that looked at the effect of two different concentrations of glucose on biomass and astaxanthin production by *Phaffia rhodozyma*, the Mineral Salts Medium was used. For these experiments, the shake flask system of culture was used. The same ingredients as shown in Table 3.4.2.1.2 were

used, but glucose was added to the medium at two concentrations, 1% (10 g/l) and 1.5% (15g/l).

3.4.2.3 Addition of Fresh Substrate

Supplementation tests were also carried using the shake flask system. The parent strain (NCYC 874) and a mutant strain (NRRL-Y-18734) of *Phaffia rhodozyma* was cultured in the mineral salts medium, the ingredients of which are shown in Table 3.4.2.1.2 . 1% and 1.5% glucose was used as the carbon source. Two ‘control’ cultivations were carried out at each glucose concentration used. No additional glucose was added to these cultures. Two ‘supplemented’ cultivations were carried out at each glucose concentration used. Additional glucose at the appropriate concentration was added to these cultures after 120 hours. Additional substrate in the form of sterile glucose solutions, at both concentrations used, was aseptically added to the supplemented cultures at the appropriate time.

Growth of the cultures was assessed using optical density measurements (Section 3.5.2). Astaxanthin production was assessed using the spectrophotometric method of analysis (Section 3.7.1.1). For overall assessment of growth, the dry weight of the yeast per 25 mls of culture fluid was determined for each 24 hour period (Section 3.5.1).

Each cultivation had four individual sets of results for each test parameter. The mean of the four results was calculated, and statistical analysis carried out to determine the range of error of the mean (Section 3.10.1). Analysis of the data was also carried out to determine the extent of correlation between the test parameters, and was carried out using as described in Section 3.10.2 of this chapter.

3.4.2.4 Consumption of carbon and nitrogen sources

Consumption of glucose and nitrogen by the parent strain (NCYC 874) and a mutant strain (NRRL-Y-18734) of *Phaffia rhodozyma* was investigated, when both strains were cultivated in both shake flask and fermenter culture. The mineral salts medium was the growth medium used. The basic ingredients as shown in Table 3.4.2.1.2. were used. Glucose concentration was measured using the Dinitrosalicylic method described in Section 3.9.1 of this chapter.

Nitrogen concentration was determined using the Phenol Nitroprusside method described in Section 3.9.2 .

3.4.2.5 Cultivation of the parent strain (NCYC 874) and a mutant strain (NRRL-Y-18734) of *Phaffia rhodozyma* in shake flask culture

The parent strain (NCYC 874) and a mutant strain (NRRL-Y-18734) of *Phaffia rhodozyma* were cultivated in shake flask culture, under conditions described in Section 3.2 of this chapter. Ten shake flask cultivations were carried out using the parent strain (NCYC 874) of the yeast. Five of these cultivations were carried out using a yeast malt broth to culture the yeast, and five cultivations were carried out using a mineral salts medium to culture the organism. Another ten cultivations were carried out, using the mutant strain (NRRL-Y-18734) of the yeast. Five cultivations were carried out using a yeast malt broth as the growth medium, and five were carried out using the mineral salts medium to culture the organism. Each cultivation was given a number. Cultivations were divided into four groups (Table 3.4.2.5.1) on the basis of the growth medium used to culture the yeast.

Table 3.4.2.5.1 Division of cultivations of the parent strain (NCYC 874) and a mutant strain (NRRL-Y-18734) of *Phaffia rhodozyma* cultured in a yeast malt broth and mineral salts medium

Strain of <i>Phaffia rhodozyma</i>	Cultivation Number
Parent strain (NCYC 874) grown in a yeast malt broth	1 to 5
Parent strain (NCYC 874) grown in a mineral salts medium	6 to 10
Mutant strain (NRRL-Y-18734) grown in a yeast malt broth	11 to 15
Mutant strain (NRRL-Y-18734) grown in a mineral salts medium	16 to 20

Pigment levels were assessed using the spectrophotometric method described in Section 3.7.1, after homogenisation of the samples. Growth of the culture was assessed using optical density measurements (Section 3.5.2). Biomass levels were determined using the technique described in Section 3.5.1 . Glucose concentration was determined using the method described in Section 3.9.1, and

nitrogen concentration was determined using the technique described in Section 3.9.2 .

Each cultivation had five sets of results for each test parameter. Each replication of an analysis produced ten results, for Time zero to Time 240. This gives a total of 50 results for each parameter tested. The statistical process was simplified by using the average result of the five replications, for each parameter. Data was sorted in this manner for cultivations 1 to 5, 6 to 10, 11 to 15, and 16 to 20, and analysed statistically as described in Section 3.10.1 of this chapter. Analysis of the data was also carried out to determine the extent of correlation between the test parameters, and was carried out using as described in Section 3.10.2 of this chapter.

3.4.2.6 Cultivation of the parent strain (NCYC 874) and a mutant strain (NRRL-Y-18734) of *Phaffia rhodozyma* in a laboratory fermenter

The parent strain (NCYC 874) and a mutant strain (NRRL-Y-18734) of *Phaffia rhodozyma* were cultivated in a laboratory fermenter. One cultivation was carried out using the parent strain (NCYC 874) of the yeast, and one cultivation was carried out using a mutant strain (NRRL-Y-18734) of the yeast. A mineral salts medium was used as the growth medium, the basic ingredients of which are given in Table 3.4.2.1.2 . Cultivations lasted for 180 hours. Culture conditions were kept controlled. The pH was maintained between 4 and 5, the temperature was maintained between 20 to 22°C and air was pumped into the fermenter at a rate of 1.5 l per minute.

Pigment levels were assessed using the spectrophotometric method described in Section 3.7.1, after samples underwent enzyme treatment (3.7.2). Growth of the culture was assessed using optical density measurements (Section 3.5.2). Biomass levels were determined using the technique described in Section 3.5.1. Glucose concentration was determined using the method described in Section 3.9.1, and nitrogen concentration was determined using the technique described in Section 3.9.2 . Qualitative analysis of *Phaffia rhodozyma* extracts was carried out using Thin Layer Chromatography (Section 3.8.1) and High Performance Liquid Chromatography (Section 3.8.2).

Each run had three individual results for each test parameter. The mean of the three results was calculated, and statistical analysis of the data generated was

carried out as described in Section 3.10.1 of this chapter. The extent of the correlation between the test parameters was determined as described in Section 3.10.2 of this chapter.

3.4.2.7 Preparation of Medium for Fermenter

Two media were used in the fermenter. The Mineral Salts Medium, prepared as previously described using ingredients shown in Table 3.4.2.1.2, and a yeast malt broth, prepared using the ingredients shown in Table 3.4.2.1.1, were used to culture the yeast. A 1L volume of medium was used in the culture vessel.

3.5 Analytical Methods for Growth Analysis

The analytical techniques used to determine biomass and pigment production by *Phaffia rhodozyma* during the growth cycle are of paramount importance. The techniques used for determination of growth are standard microbiological techniques. Two analytical techniques used in this project to determine yeast growth were turbidity and biomass measurements. Two additional techniques were used in the earlier section of this research, in the experiments looking at the growth of *Phaffia rhodozyma* in different growth media. These methods were used to determine the total and viable numbers of cells in a given sample of medium. The two techniques used were; direct microscopic counting of yeast cells using the Haemocytometer, and counting of viable yeast cells using the Pour Plate Method. The various techniques mentioned will now be described in full.

3.5.1 Biomass Determination

Biomass determination is used to measure yeast growth. 25 ml samples were taken from the shake flask cultures, and centrifuged at 4400 rpm for 15 minutes to separate the cells from the broth. After centrifuging, the supernatant was collected, to be used in the glucose and ammonia determinations. The pellet of cells was washed in distilled water to remove any remaining broth. Re-centrifuging at 4400 rpm for 8 minutes was then carried out. The cells were mixed with enough distilled water to provide a cell suspension with a final volume of 25 mls. This mixture was poured into a weighing dish, which has been previously dried in an oven at 102°C for 24 hours. The dish containing the cell suspension was then placed in an oven for 24 hours at a temperature of

102°C. After this time the dish was weighed, and the tare weight subtracted to give the dry cell weight per 25 mls of sample.

With samples taken from the fermenter, the procedure used was different. A 5 ml sample volume was used. The sample was centrifuged as stated previously. The pellet of cells was washed twice with distilled water. The cells were re-centrifuged as stated previously, and the excess broth retained for the glucose and ammonia determinations. 5 mls of distilled water was added to the cell pellet which was poured into a dry weighing dish, which had been dried in an oven at 102°C for 24 hours. The dish containing the cell suspension was then placed in an oven for 24 hours at 102°C. The dry cell weight (DCW) was calculated as:

$$\text{DCW (g/l)} = Y \text{ g} / 5.0 \times 1,000$$

Where: 5.0 = sample volume used
 1,000 = converts mls to g
 Y = weight of cells

3.5.2 Turbidity Measurements

An increase in turbidity can be used as a measure of an increase in microbial numbers or cell mass. The amount of light that is transmitted decreases as the number of cells increases. This method can only be used where the turbidity of the broth is due to the cells alone. Yeasts fall into this category. However, in the case of *Phaffia rhodozyma*, the presence of pigment in the cells can cause misleading absorbance readings. Up to five replicate samples were analysed using this method, to obtain reliable results.

The use of this method involves measuring the absorbance of a suspension of cells at a particular wavelength, using a UV Spectrophotometer. The absorbance at the chosen wavelength is referred to as the Optical Density, or O.D. This is usually measured at a wavelength of between 500 and 700 nm. The wavelength chosen to measure O.D. in this research was 600 nm. This was determined by scanning several samples taken from yeast cultures on the spectrophotometer, which determined the wavelength that gave the most reliable absorbance results for the samples tested. Scanning of samples was

carried out to keep the interference caused by cellular pigment to a minimum, as the maximum wavelength (λ max) for carotenoid pigments lies between 450 and 500 nm. The absorption of light was measured in a Hitachi U-1100 UV-VIS Spectrophotometer, with sterile medium being used as a reference cell.

3.5.3 Total Cell Count

The use of a counting chamber called the Haemocytometer, is common practice when a count of the total number of microorganisms in a suspension is needed. Counts of the total number of yeast cells in samples collected from the shake flask cultures were obtained using this method. Figure 3.5.3.1 shows the basic dimensions of the counting chamber.

The haemocytometer is a special glass slide and cover slip, which holds a volume of 0.1 mm^3 ($1 \text{ mm}^2 \times 0.1 \text{ mm}$ deep). The surface of the slide is etched into 400 small squares so that when the cover slip is in place, the volume over one of these small squares is $0.1 / 400 \text{ mm}^3$.

Using a pasteur pipette, a small amount of the cell suspension is withdrawn. A small drop is deposited on the polished surface of the counting chamber. The suspension enters the chamber by capillary action. Cells should only fill the space between the cover glass and the counting chamber. For counting yeast cells, the middle square is used. In Figure 3.5.3.1 the middle square is circled, and contains 25 squares, each bounded by three grid lines indicated in the diagram by heavy black lines. All the cells in the middle square (indicated in the diagram by an X) are counted. At least 200 cells should be counted to obtain an accurate cell count.

The number of cells per 1 ml of culture, may be determined in the following way. The middle square has a volume of 0.1 mm^3 . The number of cells in the middle square multiplied by 10 will yield the number of cells per 1 mm^3 in the culture. That number of cells multiplied by 1000 will give the number of cells per 1 cm^3 , of culture. Therefore, if the total middle square is counted, that number of cells is multiplied by 10^4 to yield the number of cells per ml. If only 5 squares within the middle square is counted, the cell number should be multiplied by 5×10^4 to yield the number of cells per 1 ml.

If the sample being analysed is very concentrated, dilutions are made. The dilution factor must be accounted for when calculating the number of cells per ml of original sample.

Figure 3.5.3.1 Basic Dimensions of the Haemocytometer

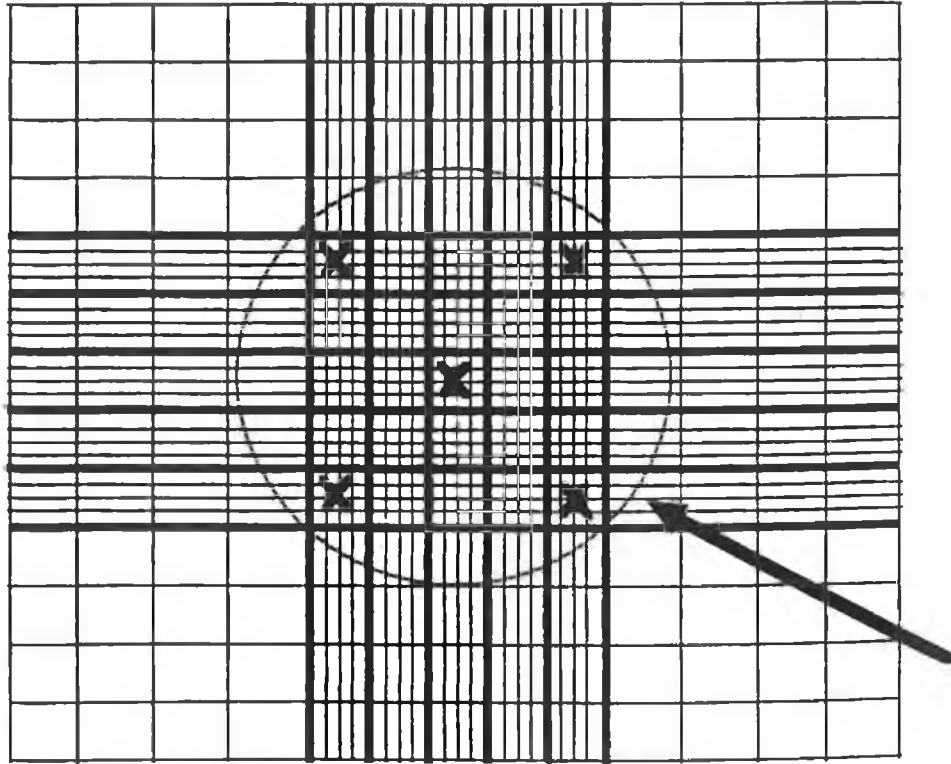

3.5.4 Viable Cell Count

The haemocytometer is used to give the total number of cells in a suspension. This method does not discern whether the cells are viable or not. Therefore, a method is needed to determine the number of viable cells in a sample.

The Pour Plate method is a technique routinely used to determine the number of viable cells in a sample of broth, and this was the method chosen for the purpose of this research.

The first stage in this method is the preparation of a number of dilutions of the sample, using serial dilution. Serial dilution is carried out by making ten fold dilutions of the sample, up to a 10^6 dilution. Half strength sterile Ringers solution is used as a diluent. The dilutions are made as follows according to standard procedure.

10⁻¹ -1 ml of sample is aseptically transferred to a sterile universal containing 9 mls of ringers solution. This is the 10⁻¹ dilution.

10⁻² -1 ml of the 10⁻¹ dilutions is aseptically added to a universal with 9 mls of diluent. This is the 10⁻² dilution.

10⁻³ -1 ml of the 10⁻² dilution is added to 9 mls of diluent. This is the 10⁻³ dilution.

The procedure is continued until a 10⁻⁶ dilution is obtained. The 10⁻⁶ dilution is effectively a one in a million dilution of the original sample.

In the Pour Plate method 1 ml of the diluted sample is aseptically transferred into an empty petri dish. Each sample being tested is done in triplicate. Cool molten agar is added to the petri plates, which are then swirled to mix the contents of the plate evenly. After the agar has cooled, the plates are incubated at 22°C for 24 hours. The resulting colonies are counted and the results are reported as colony forming units (c.f.u.) present per 1 ml of sample. This is obtained by using the following formula:

$$\text{No. of c.f.u./ ml of sample} = \text{No. of c.f.u. counted} \times \text{dilution factor}$$

When more than 300 colonies are present on a plate, over-crowding occurs. As the number of colonies decreases the sampling error increases. Therefore, only counts recorded in the range of 30 to 300 c.f.u. per plate were reported, as this is deemed statistically acceptable.

3.6 Growth Kinetics

Microbes grow in such a way that the rate of growth is proportional to the cell concentration already present. Cells grown in a batch culture generally experience four distinct growth phases: a lag phase, an exponential phase, a stationary phase and a death phase. Once the cells adjust to a new medium growth begins rapidly. Cells in the exponential phase are growing rapidly and most are in the same physiological state.

3.6.1 Specific Growth Rate

During exponential growth, the cell number (or dry cell weight) increases in the manner:

$$X_0 \rightarrow 2X_0 \rightarrow 4X_0 \rightarrow 8X_0 \text{ etc.}$$

Here, X is the cell concentration, and the interval between each doubling is constant, and is called the Doubling Time (g). The number of doublings (n) after time (t), is given by:

$$n = t / g$$

The cell density at time (t) is related to the original cell density (X_0) in the following manner:

$$X_t / X_0 = 2^{t/g}$$

Taking logarithmic yields:

$$\ln X_t / X_0 = \ln 2 t / g$$

Therefore,

$$\frac{\ln X_t - \ln X_0}{t} = \frac{\ln 2}{g}$$

A plot of $\log_e X$ versus time yields a straight line with a slope of $\ln 2 / g$. This is called the Specific Growth Rate, or μ , and is usually determined by finding the slope of the exponential phase of the growth curve.

In the experiments which looked at the growth of *Phaffia rhodozyma* in various growth media, the specific growth rate was used to determine which medium supported the best growth. The specific growth rates were calculated using the viable cell count results obtained.

3.7 Analytical Methods for the Extraction and Analysis of Astaxanthin from *Phaffia rhodozyma*

The extraction of the carotenoid pigments contained in the cells of the yeast *Phaffia rhodozyma* must be achieved in order to allow the pigments to be quantitatively analysed. Many methods have been used for the extraction of astaxanthin from the cells of *Phaffia rhodozyma*, and these have been discussed

in detail in the previous chapter. These methods include both mechanical and enzymatic techniques, some of which have been successful. The use of a Braun Homogeniser as a mechanical method of pigment extraction was utilised throughout this project, and was found to be very successful. Three commercially available enzymes :- Novozyme 234, SP299 Mutanase (Novo Bioindustries, Denmark) and Lyticase (Sigma Chemical Company, U.K.) were used to rupture the cell walls to release the pigment.

3.7.1 Mechanical Cell Breakage

Initial work concerning the release of pigment from the yeast cells by rupturing the cell wall, was carried out using a Braun rotary cell homogeniser (Braun AG., Melsungen, Germany). Mechanical rupturing of the yeast cells was carried out using the parent strain (NCYC 874) of the organism.

3.7.1.1 Optimisation of Cell Breakage Procedure

The optimum conditions for the extraction of astaxanthin from the yeast cells were determined by varying the conditions under which homogenisation took place i.e. volume of acetone used, weight of beads used and the duration of the homogenisation process. The weight of yeast cells used in the experiment was 1 g. Agar plates were streaked using slant cultures of *Phaffia rhodozyma* (strain NCYC 874). The plates were incubated at 20°C for five days. Cells were scraped off the plates using a microscopic slide, and collected in a glass beaker. The beakers were covered in tinfoil, and stored in the refrigerator at - 4°C until the cells were used.

Duplicate homogenisation runs were carried out using 5 mls of acetone, and a cell to bead ratio ranging from 1:1 to 1:9. Homogenisation took place for six minutes, at intervals of two minutes each, to allow sufficient cooling of the homogeniser. A control sample was used, which underwent no homogenisation. Another set of duplicate homogenisations was carried out, this time using 10 mls of acetone and a cell to bead ratio ranging from 1:1 to 1:9. Again, homogenisation took place for six minutes. As before, the control sample underwent no homogenisation. Percentage extraction of astaxanthin determined the effectiveness of homogenisation, and was calculated using the following formula:

$$\% \text{ Extraction of Astaxanthin} = \frac{\text{Abs 480 (Sample - Control)}}{\text{Abs 480 of Sample}} \times 100$$

As a result of this experiment, 5 mls of acetone, 4.5 g of glass beads followed by six minutes homogenisation, was determined to be the optimum conditions for cell breakage using the Braun homogeniser.

3.7.1.2 Cell Breakage Procedure

The material to be homogenised is poured into a Duran glass bottle which has a ground glass stopper with a special rubber lip that holds the stopper in place during the procedure. A 25 ml sample volume is used. The sample together with 4.5 g of glass beads (0.5 mm in diameter) and 5 mls of acetone, are all poured into the bottle. The bottle is placed in the homogeniser and homogenisation is carried out for six minutes.

The body of the homogeniser consists of a heavy steel tube. The axis of this steel tube is capable of carrying out a circular motion at a speed of 2000 or 4000 rpm. The tube itself runs in heavy roller bearings, and is prevented from rotating through tension springs. A second steel tube surrounds the eccentric tube carrying the glass bottle, and provides external protection. The entire equipment is carefully balanced and is supported on flexible mounts. The homogeniser bottle containing the cell material, acetone and glass beads is cooled using liquid carbon dioxide which is provided by a cylinder. A flexible steel capillary is attached to the machine and allows cooling to take place. The temperature of the material can be kept at or around 5°C.

The homogenisation process should result in the breakage of of substantially all the cells present in the sample, which is verified microscopically using a phase contrast microscope. Once the homogenisation process was complete, the mixture containing the broken cells and beads was poured into a centrifuge tube, and centrifuged for 15 minutes at a speed of 4400 rpm. The supernatant containing the pigment was collected carefully. The pigment content of the sample was determined by spectrophotometric analysis. The absorbance of the sample was measured at 480 nm. All samples taken from the shake flask cultures were analysed in this way. Acetone was used as a reference cell. The

concentration of astaxanthin in the sample was calculated using the following formula:

$$\text{mg astaxanthin / 25 mls of sample} = \frac{A_{480} \times \text{volume}}{E_{1\text{cm} / 1\%} \times 100} \times 1000$$

Where:

- A = Absorbance measured at 480 nm
Volume = Volume of acetone used in the procedure
 $E_{1\text{cm} / 1\%}$ = Extinction Coefficient of astaxanthin in acetone (which is 1600)

3.7.2 Enzymatic Cell Breakage

While cell breakage using the Braun Homogeniser proved to be successful, the process itself was very time consuming. Consequently, an alternative method of cell breakage which would be quicker but as effective as homogenisation, was investigated.

3.7.2.1 Introduction

Enzyme preparations are available, which digest the cell wall of *Phaffia rhodozyma*, allowing the release of pigment from the cells. Three enzymes were chosen for investigation: Lyticase (Sigma Chemical Co., U.K), Novozyme 234 and SP 299 Mutanase (Novo Bioindustries, Denmark). This last enzyme is not yet commercially available, however, several samples of the product were available from the manufacturer. Enzymatic cell breakage was carried out using the parent strain (NCYC 874) and the mutant strain (NRRL-Y-18734) of the yeast.

Lyticase and SP 299 Mutanase are two enzyme preparations that contain a digestive enzyme obtained from the fungus *Trichoderma harzimum*. An effective amount of these digestive enzyme preparations has been shown to be capable of digesting the cell wall of *Phaffia rhodozyma* (Torregrossa, R., and

Prevatt, W.D. 1991). Both Lyticase and SP 2999 Mutanase allow the release of pigment from the yeast cells by digesting the cell wall. Another multi component enzyme preparation Novozyme 234, also contains a digestive enzyme isolated from *Trichoderma harzimum*. This enzyme works by modifying the yeast cell wall, so that astaxanthin extraction is possible.

All of the above enzyme preparations work under specific conditions. All three require a temperature in the range 21 to 24°C, at a pH between 4 and 5, allowing a contact time of at least six hours. The amount of enzyme preparation used on a cell suspension containing 20-100 mg of cells, is approximately 50 to 500 mg per ml. SP 299 Mutanase was found to be the most effective enzyme preparation tested, allowing the release of astaxanthin from the yeast cells.

3.7.2.2 Optimisation of Cell Breakage Procedure

The optimum conditions for the extraction of astaxanthin from the cells using SP 299 Mutanase were determined by varying the conditions under which digestion of the cell walls took place. These included:

- varying the concentration of the enzyme;
- varying the contact time between the enzyme and cells;
- and 'pre-softening' the cells with different concentrations of acid, prior to contacting the cells with the enzyme.

A 4 mls sample of culture was found to contain approximately 50 mg of cells, therefore a sample volume of 4 mls was used for this procedure. This ensured that the weight of cells in the sample was within the range recommended by the enzyme manufacturer (Novo Bioindustries, Denmark). Three enzymes were tested to determine which was most effective at releasing pigment from the yeast cells. Lyticase, Novozyme 234 and SP 299 Mutanase were the three enzyme preparations tested. Enzyme concentrations ranging from 50 mg/ml to 500 mg/ml were used. The enzyme standards were prepared using either water or phosphate buffer, depending on the enzyme used. Where water was used to make up the enzyme standard, the pH of the solution was adjusted to 4.5 using the phosphate buffer.

Samples were centrifuged and the enzyme preparations were contacted directly with the cells. Samples were incubated at 20°C for 24 hours. A control sample was used which underwent no enzyme treatment. After incubation, samples were centrifuged and acetone was added to the samples which were left to stand for an hour. Samples were then re-centrifuged and the supernatant containing the pigment was collected. The absorbance of the samples was measured at 480 nm. Percentage extraction of astaxanthin was calculated using the formula given in Section 3.7.1.1 . Percentage extraction of astaxanthin determined the effectiveness of a specific enzyme at releasing pigment from the cells.

As a result of this experiment, SP 299 Mutanase was determined to be the most effective enzyme preparation tested. To optimise the release of astaxanthin from the cells using Mutanase, pre-treatment of the cells was carried out using hydrochloric and sulphuric acid. Concentrations of acid in the range 0.5 M to 2.0 M were used. As before, a 4 mls sample volume was used. A control sample was used which underwent no enzyme or acid treatment. Samples were centrifuged at 4400 rpm for 15 minutes. The supernatant was poured off, and the acids at the various concentrations were contacted directly with the cells. Samples were incubated at 20°C, 40°C, 60°C and 80°C for 24 hours in shaking water baths set at the appropriate temperature. After incubation samples were re-centrifuged, and 250 mg/ml SP 299 Mutanase contacted directly with the cells. Samples were incubated at 20°C for 24 hours. After this time samples were centrifuged, and the supernatant poured off. Acetone was added to the samples which were centrifuged at 4400 rpm for 10 minutes. The absorbance of the samples was read at 480 nm, and the percentage extraction of astaxanthin calculated using the formula given in Section 3.7.1.1 .

As a result of this experiment, pre-treatment of samples using 2M hydrochloric acid, at an incubation temperature of 60°C, for 24 hours, followed by enzyme treatment using 250 mg/ml SP 299 Mutanase, was determined to be the optimum conditions for enzyme treatment, allowing effective release of pigment from *Phaffia rhodozyma* cells.

3.7.2.3 Cell Breakage Procedure

Enzymatic digestion of the yeast cells was carried out in the following manner. The sample was centrifuged at 4400 rpm for 15 minutes. The supernatant was

poured off and retained for glucose and ammonia analysis. The cells were 'pre-softened' by adding 2 mls of 2M HCL to the pellet of cells. The sample was incubated for 24 hours, at a temperature of 60°C in a water bath. The use of acid to pre-soften the cells followed by enzyme digestion, was found to be more effective than the use of enzyme on its own, in digesting the cell wall leading to the release of the pigment from the cells.

After treatment of the cells, the acid was poured off. The cells were washed with distilled water, and the suspension was centrifuged at 4400 rpm for 10 minutes. A concentration of 250 mg/ml SP 299 Mutanase was added to the cells and the sample was incubated at 20°C for 24 hours in a shaking water bath. After the cells had been contacted with the enzyme for 24 hours, the sample was centrifuged at 4400 rpm for 15 minutes. The supernatant was discarded. A known volume of acetone was added to the cells, and the mixture was left to stand for an hour. The cell suspension was centrifuged at 4400 rpm for 10 minutes, and the supernatant containing the pigment, was collected. The absorbance of the sample was measured at 480 nm. Acetone was used as a reference cell. Astaxanthin concentration obtained using this method of cell digestion was recorded as mg astaxanthin per g of cells using the following formula:

$$\text{Astaxanthin (mg / g cells)} = \frac{\text{A}_{480} \times \text{Volume}}{\text{E}_{1\text{cm} / 1\%} \times 100} \times 1000 / \text{CF}$$

Where;

- A = Absorbance measured at 480 nm
- Volume = Volume of acetone used in the procedure
- E_{1cm / 1%} = Extinction Coefficient of astaxanthin in acetone (which is 1600)
- CF = Calculation Factor which converts from mg astaxanthin per 50 mg cells to mg pigment per g of cells

All samples taken from the fermenter were analysed in this way.

3.8 Analytical Techniques for the Analysis of Astaxanthin from *Phaffia rhodozyma*

The analysis of carotenoid pigments synthesised by *Phaffia rhodozyma* during the growth of the yeast can be achieved using various sophisticated techniques. Both quantitative and qualitative analysis of the carotenoids was carried out. Qualitative analysis of the pigments was carried out using Thin Layer Chromatography (TLC), and quantitative analysis was carried out using a spectrophotometric technique, and High Performance Liquid Chromatography (HPLC).

3.8.1 Analysis of Astaxanthin Using Thin Layer Chromatography

Thin Layer Chromatography (TLC) is a relatively simple method to use in order to resolve the component carotenoids present in *Phaffia rhodozyma* extracts. The use of TLC is invaluable in allowing the visualisation of the various components by observing the colour unique to each carotenoid. In recent years, the choice for the rapid analysis of complex samples has been the use of High Performance Liquid Chromatography (HPLC). However, the use of TLC as an analysis tool has the following advantages;

- Simultaneous analysis of multiple standards and samples can be carried out under identical conditions, in a time comparable to HPLC;
- TLC is a relatively inexpensive method to use;
- and all components can be located, unlike in HPLC, where highly polar materials may be overlooked.

TLC is an invaluable tool, allowing the fast, reproducible, qualitative separation of the individual components of a sample to be carried out.

Pre-coated glass plates of silica gel (Whatman, 5 x 20 cm, 25 μ m layer) with an added fluorescent agent, were used straight from the box. The mobile phase used was a hexane : butanone : methanol mix, in the ratio 90 : 5 : 5 . Pure crystalline samples of astaxanthin and β -carotene (obtained from Roche

Vitamins and Chemicals, Welwyn Garden City, Herts., U.K.) were used to prepare standards.

A 20 ml volume of the developing solvent was used for the separation of the pigments. The solvent mix was left in a covered beaker for 2 hours to equilibrate. A small line was drawn 15 mm from the end of the plate, and this was known as the baseline of the chromatogram. A scalpel was used to etch a line 15 mm from the top of the plate. This ensured that the solvent did not travel further than this line. All standards prepared were of a 1 mg / ml concentration, and were prepared in methanol. Two samples used in this analysis were chosen at random. Enzymatic digestion of the samples was carried out, and the pigments extracted into methanol. A sample volume of 2 mls was used. The two samples containing the extracted pigment and methanol, were poured into two separate weighing dishes, and left into the fume cupboard for 15 minutes, until the sample volume was reduced, therefore allowing the samples to become more concentrated. This allowed better separation of the individual components of the sample.

TLC was carried out according to normal procedure. The intensity of the sample spots should be strong, to ensure that enough of the sample has been applied. All spots applied to a plate should be at least 15 mm apart, to prevent one sample spot merging with another. Two standards and one sample were applied to each plate. Four TLC plates were used for each analysis, as two samples (in duplicate) were analysed each time.

As the individual carotenoids in the test sample began to travel up the plate, the colour and size of each carotenoid was noted. The R_f values for the standards and samples were calculated using the following formula:

$$R_f = \frac{\text{Distance travelled by spot}}{\text{Distance travelled by the solvent front}}$$

All measurements were taken from the baseline. The only accurate way that the R_f value can be used for identification is by comparison TLC, therefore the sample and two standards were run on the same plate.

3.8.2 Analysis of Astaxanthin Using High Performance Liquid Chromatography

Prior to the analysis of samples using HPLC, extraction of the pigment from the cells was achieved exclusively by enzymatic means according to the procedure described previously.

3.8.2.1 Preparation of Standards

Synthetic astaxanthin and β -carotene were used to prepare standards. 1 mg of each synthetic carotenoid was weighed out accurately and dissolved in 1 ml of the HPLC solvent, which was methanol. The standards were injected directly into the HPLC equipment prior to any sample analysis being carried out.

3.8.3.2 Sample Preparation

Replicate samples of 1 ml were taken from fermenter and shake flask cultures. The samples were spun down, and the wet weight of the samples was determined. 1 ml of sample was found to contain approximately 25 mg of cells. It is recommended that samples being analysed using HPLC, should have a cell concentration of between 10 to 50 mg ml, to obtain reproducible results (Torregrossa *et al.* 1991). Prior to samples being analysed using HPLC, the pigment was extracted from the yeast cells by enzymatic means.

All samples were first spun down after enzyme treatment, and the supernatant containing the enzyme solution is discarded. The cells were washed with 2 mls of distilled water to clean excess enzyme from the cells. The samples were then centrifuged for 10 minutes at 4400 rpm. The distilled water was poured off, and 1.5 mls of methanol was added to the cells. The samples were left to stand for 15 minutes, after which time it was centrifuged at 4400 rpm for 10 minutes. The supernatant was carefully poured into a clean eppendorf tube and capped. All samples and standards were kept sealed to prevent organic solvents evaporating, which would affect the concentration of pigment present. All vessels containing samples and standards were covered in foil as carotenoid pigments are sensitive to light.

3.8.2.3 HPLC Conditions

As can be seen from the literature, many combinations of columns and solvents have been used by various researchers. In this project, reverse phase HPLC was carried out using an Alltech C¹⁸ (Econosphere), 5 μ , 250 mm x 4.6 stainless steel column; with methanol as an eluting solvent at a flow rate of 0.5 ml per minute; with the eluant monitored at a wavelength of 471 nm. A summary of the HPLC conditions used in this project is given in Table 3.8.3.3.1 .

The solvent used was of HPLC grade, degassed and filtered through a 0.5 μ m filter. Columns were flushed with the solvent between runs. The pump pressure was increased to allow a flow rate of 1 ml per minute, and solvent was run through the column at this faster flow rate for 2 hours, to flush unwanted materials from the column.

Table 3.8.2.3.1 Summary of HPLC Conditions Used in the Quantitative Analysis of *Phaffia rhodozyma* Carotenoids

Column Used	C18, 5 micrometer, 250 mm (length) x 4.6 mm (internal diameter)
Mobile Phase	Methanol
Flow Rate	0.5 ml per minute
Detection Wavelength	Visible Wavelength HPLC Detector set at 417 nm
Injection Volume	20 microlitres
Temperature	Ambient
Sample Solvent	Methanol
Lamp Used	Tungsten Lamp

Calibration of the chart recorder was achieved using the carotenoid standards. Replicates of the standards were run through the system, with the peak heights and retention times being noted. A summary of the chart conditions used in this project is given in Table 3.8.2.3.2 .

Table 3.8.2.3.2 Summary of Chart Recorder Conditions Used in HPLC Analysis of *Phaffia rhodozyma* Carotenoids

Slope	10 (uV / min)
Minimum Peak Width (Half Height)	10 seconds
Baseline Drift Value	0 (uV / min) or Auto
Minimum Peak Height	100 Counts
Time	0 or Auto
Analysis Stop Time	500 minutes
Attenuation	0 or Auto
Chart Speed	10 mm / min

To achieve reproducible results the injection of a sample into a HPLC system must be carried out in the correct manner. The loop capacity available with the HPLC apparatus used in this project was 20 μ l. Therefore, a syringe with a capacity of 20 μ l was used to inject the samples into the loop. It is important to follow the manufacturers instructions for filling the loop.

3.9 Analysis of Culture Fluids

3.9.1 Introduction

Analysis of the culture fluids was carried out for two reasons - to measure the disappearance of the carbon source and the nitrogen source during the period of growth of the organism.

Glucose was the carbon source used in the various growth media utilised in this project. To monitor the disappearance of the carbon source, the amount of glucose remaining in the growth medium was measured in order to determine how much of the carbon source was consumed by the yeast during growth.

Ammonium sulphate was the nitrogen source used in the various growth media utilised during this project. In order to investigate the disappearance of the nitrogen source, the amount of ammonia present in the medium was measured. This allowed the disappearance of the nitrogen source to be measured - in order to measure how much was being consumed by the organism during growth.

3.9.2 Glucose Determination

Glucose concentration was measured using the Dinitro Salicylic (DNS) Method for reducing sugars (Sumner, J.B., and Somers, F. 1949). Samples from either a shake flask or fermenter culture were centrifuged at 4400 rpm for 15 minutes. The cells were washed with distilled water, the re-centrifuged at 4400 rpm for 10 minutes. The clear supernatant, containing the spent medium, was collected. The supernatant was then analysed using the DNS method, to determine the concentration of glucose in the sample.

A sample was taken from an uninoculated flask of the same medium, as was being used in to culture the organism. This was used as the control, to measure the amount of glucose present in the fresh medium. The concentration of glucose in the control is measured using this method, to confirm the amount of glucose added to the medium at the start of the experiment. Analysis of the control also allows the accuracy of the method to be tested.

A stock solution of 10 mg per ml glucose was prepared. A series of standards was prepared from this stock solution, in the range 0.1 mg / ml, 0.25 mg / ml, 0.5 mg ml, 1.0 mg /ml, 2.5 mg / ml and 5.0 mg / ml glucose. A standard curve was prepared using these standards. Dilution of the sample is carried out if the absorbance of the sample does not fall within the range measured by this assay.

A sample volume of 1 ml was used. A blank of distilled water was used as the control. 1 ml of each of the glucose solutions (samples and standards) are added to clean test tubes. 1 ml of water is added to all of the tubes. 2 mls of the DNS reagent, prepared according to the standard procedure, is added to all the test tubes. The reagent blank is treated in exactly the same way as the standards and samples, except that 1 ml of water is used instead of glucose. The tubes are placed into boiling water for ten minutes, after which they are left to cool, and 10 mls of water is added to each sample. The absorbance of the standards and samples are measured using a UV Spectrophotometer, at a wavelength of 540 nm. A calibration curve is prepared using the standard results. This curve is used to determine the concentration of glucose in the test samples.

3.9.3 Nitrogen Determination

Nitrogen concentration was measured using the Phenol Nitroprusside Method (Scheimer, D. 1976). This is a colourimetric method which is based on the Berthelot reaction, and allows the concentration of ammonia in the spent medium to be measured. The Berthelot reaction is based on the development of a deep blue colour which occurs when ammonia reacts with phenol and alkaline hypochlorite. The nitrogen source used in the mineral salts medium was ammonium sulphate. The biochemical breakdown of this compound into ammonia is measured using this method. This method allows the consumption of the nitrogen source by *Phaffia rhodozyma* to be measured. Results are reported as mg / l N. This method gives highly reproducible results in the range of 0.2 - 10 mg / L N. This method is also quick and relatively simple to use.

Samples from either a shake flask or fermenter culture were centrifuged for 15 minutes at 4400 rpm. The cells were washed twice with distilled water, and re-centrifuged at 4400 rpm for 10 minutes. The clear supernatant was collected. This clear supernatant, or spent medium, was then analysed using the phenol nitroprusside method. A sample was also taken from an uninoculated flask of the same medium, as was being used to culture the organism. This was used as a control sample, and allowed the concentration of ammonia in the fresh medium to be measured.

A stock solution of 1000 mg / L ammonia was prepared. A working standard of 50 mg / L was prepared from the stock solution. A range of standards was prepared from this working standard, in the range; 0.1 mg / L, 0.2 mg / L, 0.4 mg / L, 0.6 mg / L, 0.8 mg / L, 1.0 mg / L, 5.0 mg / L and 10.0 mg / L. A standard curve was prepared from the absorbance readings obtained using these standards. Dilution of samples was carried out if the absorbance reading obtained for the sample was outside the range measured by this assay.

A sample volume of 5 mls was used. A blank was prepared using distilled water. The reagent blank is treated in the same way as the samples and standards. 2 mls of a phenol nitroprusside buffer was added to all of the samples and standards, followed by the addition of 3 mls of an alkaline hypochlorite solution. All of the samples and standards were left for 45 minutes to allow the colour to develop. The absorbance of the standards and

samples were obtained using a UV Spectrophotometer, set at a wavelength of 635 nm. A calibration curve was prepared using the absorbances obtained for the standards. This curve was used to determine the concentration of nitrogen in the samples tested.

3.10 Statistical Analysis

Statistical analysis of the data generated in this research was carried out using two methods.

3.10.1 Range of error of the mean

The results for astaxanthin, biomass and optical density obtained when *Phaffia rhodozyma* was grown in batch culture using a shake flask system and fermenter, were statistically analysed using the student's t-test. This test allows a comparison to be made between the mean values for several sets of samples. This test also allows an estimation to be made regarding the range of error of a population mean. The use of the 95% or 99% confidence levels allows this estimation to be made with 95% or 99% confidence (Spiegel, R.M. 1988).

The results obtained in this research were tested at the 95% confidence level, using the student t-test (one tailed) function available in the Microsoft Excel package on the computer. This package allowed the calculation of the range of error of the mean, for the results obtained for biomass and astaxanthin production, optical density and glucose and nitrogen concentrations, with 95% confidence. To calculate the range of error of the mean at the 95% confidence level, the following formula is used:

$$\mu (\pm) t_{0.025}^{n-1} \frac{[s]}{\sqrt{n}}$$

Where:

$t_{0.025}^{n-1}$ = obtained from the t-tables

n = No. of replications

μ = Mean value

s = Standard deviation

(n-1) = Degrees of freedom (read from the t-table)

This formula allows the assumption to be made with 95% confidence, that the mean(μ) of the population is:

$$\mu (\pm) 2.776 \times \frac{(s)}{\sqrt{n}}$$

This formula allows an estimate to be made of the range within which a given mean (μ) will lie (the range of error of the mean), with 95% confidence.

For example, if the mean result obtained for astaxanthin production by the parent strain of *Phaffia rhodozyma* after 24 hours of growth was 80 mg per 25 mls culture fluid. The number of replications (n) is five. The t value obtained from the t-test table at the 95% confidence level, with 4 degrees of freedom, is 2.776. If the number of replications carried out is more or less than five, the t-value will change, and the new value must be read from the t-tables. If the standard deviation (s) for the five replications is calculated as 10, the formula giving the estimation of the range within which the mean value will lie is calculated as:

$$80 (\pm) 2.776 \frac{[10]}{\sqrt{4}}$$

With 95% confidence, it can be stated that the mean astaxanthin value after 24 hours, is within the range 80 (\pm)13.88. Therefore, the range of error of the mean is plus or minus 13.88.

The standard deviation (s) must be calculated before the t-test can be carried out. The formula for standard deviation is:

$$s = \sqrt{\frac{\sum x^2}{n} - \frac{(\sum x)^2}{n}}$$

Where:

Σ = Sum of

n = Number of replications

x = individual result

This calculation allows the standard deviation between a set of individual results (x) to be measured.

3.10.2 Correlation

Statistical analysis was carried out to determine if there was a correlation between:

- Glucose consumption and biomass production;
 - Glucose consumption and astaxanthin production;
 - Glucose consumption and growth;
 - Biomass and astaxanthin production;
 - Biomass production and growth;
 - Astaxanthin production and growth;
 - Consumption of the nitrogen source and growth;
 - Consumption of the nitrogen source and production of astaxanthin;
 - Consumption of the nitrogen source and production of biomass;
- and
- Consumption of the nitrogen source and consumption of glucose.

To determine the extent of the linear relationship between any of these parameters, the coefficient of correlation, or r, is calculated. The coefficient of correlation is based on a scale ranging between +1 and -1. If r is positive, there is a positive correlation between the two sets of data tested. If r is negative, there is negative correlation between the data. If r is zero, there is deemed to

be no correlation between the two data sets (Spiegel, R.M. 1988). The coefficient of correlation was calculated using the Pearsons Product Moment Correlation Coefficient function available in the Microsoft Excel package on the computer. This test gives the correlation coefficient, r , between two sets of data.

When two sets of data are analysed to determine if any correlation exists between them, a strong positive or negative correlation may sometimes be obtained purely by chance. When the correlation coefficient r , is calculated for two sets of data, a significance test must be carried out on the obtained value, r , to determine if the correlation is statistically significant. This is achieved by using a one tailed t-test, at either the 95% or 99% confidence levels. This test allows the assumption to be made that there is a null hypothesis of no correlation, or: $r = 0$. The alternative hypothesis is: $r \neq 0$. The null hypothesis of no correlation is rejected if:

$$r < - \frac{r_{n-2}}{t} \text{ or } r > + \frac{r_{n-2}}{t}$$

Where:

$\frac{r_{n-2}}{t}$ = is the value obtained from the t-test statistical table

n = Degrees of freedom (calculated as n minus two, where n refers to sample number)

For the one tailed t-test, at the 95% confidence level, with a sample number of ten the t-value at n minus two (n is equal to eight) is read off the t-test statistical table, and is found to be 1.86

Using the t-value obtained from the table, the t-test statistic is calculated as:

$$t = \frac{r\sqrt{n-2}}{\sqrt{1-r^2}}$$

The obtained r value is used to calculate the t -statistic as shown above. Where the t -statistic is greater than 1.86, the null hypothesis of no correlation can be rejected, and therefore it can be stated that the correlation coefficient is significant at the 95% confidence level. If the t -statistic value is less than 1.86, the null hypothesis cannot be rejected, therefore the correlation coefficient is not significant at the 95% confidence level.

Chapter Four

Results

4.0 Results

4.1 Mechanical Cell Breakage

A major problem associated with the study of the production of astaxanthin from the yeast *Phaffia rhodozyma*, is the analytical determination of the pigment. The yeast has an extremely tough cell wall which must first be ruptured to allow the release of the pigment from the cells. Many methods have been used to rupture the cell walls of yeast, and these have been discussed in detail in Chapter Two. Much of the initial work in this project was concerned with the breakage of the yeast cells by mechanical means, using the procedure described in Chapter Three.

Rupturing the yeast cells using the homogeniser proved to be effective, allowing the release of the pigment from the cells. However, a major drawback in using this method was the lack of a standard procedure for the process. The procedure used for cell breakage varied greatly, with different procedures being used by different researchers, for example Johnson *et al.* (1976) and Torregrossa *et al.* (1991) . Thus, a uniform method for mechanical cell breakage was needed which would allow standard conditions to be applied during the procedure, while still allowing the effective release of astaxanthin from the cells.

Two main factors that affect mechanical cell breakage were identified, and these were:- the volume of the extraction solvent (acetone) used in the process, and the ratio of cells to beads used (w/w) in the procedure.

These factors were investigated in order to determine the optimum conditions for cell breakage using the Braun Homogeniser.

4.1.1 Spectrophotometric Method for Determination of Cell Breakage

To determine how much pigment was being released from the cells at each ratio of cells to beads used the percentage extraction of astaxanthin was calculated. This was obtained using a control sample which underwent no treatment.

Percentage extraction was calculated using the following formula:

$$\% \text{ Extraction of Astaxanthin} = \frac{\text{Abs 480 (Sample - Control)}}{\text{Abs 480 of Sample}} \times 100$$

4.1.2 Analysis of Results

It was found that the conditions under which homogenisation took place had a marked effect on the percentage of pigment extracted from the yeast cells.

4.1.3 Cell to Bead Ratio Used in Cell Breakage Procedure

Table 4.1.3.1 Effect of cell to bead ratio and volume of extraction solvent on the release of pigment from whole cells of *Phaffia rhodozyma*

Cell to Bead Ratio (g g)	* Percentage of astaxanthin extracted from cells using 5 mls of acetone	* Percentage of astaxanthin extracted from cells using 10 mls of acetone
0	00.00	00.00
1:1	60.70	52.84
1:2	62.34	56.08
1:3	65.11	66.12
1:3.5	67.86	69.14
1:4	71.15	73.48
1:4.5	81.67	80.47
1:5	69.49	74.14
1:5.5	71.18	71.18
1:6	64.98	64.98
1:6.5	65.25	65.56
1:7	64.71	63.27
1:7.5	59.09	59.09
1:8	57.14	53.89
1:9	49.72	46.10

* Mean Value Obtained From Duplicate Homogeniser Runs

The cell to bead ratio used during the mechanical cell breakage procedure was shown to affect the percentage of pigment extracted from the cells. Percentage of pigment extracted from the cells increased as the cell to bead ratio was increased (Table 4.1.3.1).

Maximum percentage extraction of astaxanthin from the cells was recorded using a cell to bead ratio of 1:4.5, irrespective of the volume of acetone used. at this ratio. Maximum percentage of pigment extracted from the cells was 80.47 to 81.67%. This indicates a cell disintegration efficiency between 80.47 to 81.67%.

4.1.4 Volume of Solvent Used in Cell Breakage Procedure

The volume of acetone used during the homogenisation process did not effect percentage extraction of astaxanthin. Increasing the volume of solvent by 50% resulted in the percentage extraction of pigment increasing by just 1.2%. A percentage extraction of over 80% was obtained irrespective of solvent volume used.

4.2 Enzymatic Cell Breakage

Mechanical rupturing of the yeast cells using the homogeniser was found to be effective, allowing the release of pigment from over 80% of the cells. However, as stated previously, the process itself was found to be very time consuming allowing only a small number of samples to be processed.

Several enzymes have become commercially available which allow the cell wall of *Phaffia rhodozyma* to be enzymatically digested thereby allowing the release of pigment from the cells. Two commercially available enzymes tested were SP 299 Mutanase (Novo Bioindustries, Denmark) and Lyticase (Sigma Chemical Company, U.K.). A sample of another enzyme product called Novozyme 234, which is not yet commercially available, was obtained from the manufacturer of Mutanase.

The three enzymes tested all work under similar conditions. All three require a temperature between 21 to 24°C, at a pH of between 4 and 5, allowing a contact time of at least six hours. The amount of enzyme preparation recommended for use with a cell suspension containing between 20-100 mg of cells, is 10 to 100

mg per ml of enzyme (Prevatt *et al.* (1991)). After enzyme treatment of the cells, the pigment was extracted into acetone. Percentage extraction of astaxanthin was measured as previously described. The control sample did not undergo any enzyme treatment.

From the initial results, all three enzymes were found to be very ineffective at digesting the cell wall of the yeast (Table 4.2.1). The highest percentage extraction obtained was 35.35%, using SP 299 Mutanase at a concentration of 100 mg / ml. The concentrations of enzyme used was then increased from 50 mg / ml to 500 mg / ml, to determine if effective cell digestion would occur.

Table 4.2.1 Percentage astaxanthin extracted from *Phaffia rhodozyma* cells after enzymatic treatment using three enzyme preparations

Enzyme Concentration (mg / ml)	Percentage astaxanthin extracted from cells treated with Novozyme 234	Percentage astaxanthin extracted from cells treated with Lyticase	Percentage astaxanthin extracted from cells treated with SP 299 Mutanase
0	0.00	0.00	0.00
25	5.85	6.66	12.26
50	7.99	9.25	15.89
75	11.15	16.67	25.77
100	24.33	21.23	35.35

4.2.1 Analysis of Results

The first enzyme tested was Novozyme 234. As the enzyme concentration in the assay was increased, the percentage extraction of pigment released from the cells also increased. The length of contact time was shown to effect the percentage of astaxanthin extracted from the cells. Maximum extraction of pigment from the cells was obtained after 24 hours contact time irrespective of the enzyme concentration used.

Highest percentage extraction of astaxanthin using Novozyme 234 was 89.33% (Figure 4.2.1), obtained using an enzyme concentration of 250 mg / ml after 24 hours contact time. The lowest percentage extraction was recorded at the highest enzyme concentration used.

The second enzyme tested was Lyticase. The extraction percentages recorded using this enzyme were lower than obtained using Novozyme 234. Maximum extraction of astaxanthin using Lyticase was 80.44% after 24 hours contact time, using an enzyme concentration of 250 mg / ml (Figure 4.2.2). This was almost seven percent lower than the maximum percentage extraction obtained using Novozyme 234. Efficiency of pigment extraction declined when the enzyme concentration was increased above 250 mg per ml.

The third enzyme investigated was SP 299 Mutanase. This enzyme proved to be very effective at digesting the cell walls of *Phaffia rhodozyma*. Maximum extraction of astaxanthin using Mutanase was 93.94%, after 24 hours contact time, using an enzyme concentration of 250 mg / ml (Figure 4.2.3). This was the highest percentage extraction recorded using enzymatic digestion to release pigment. The lowest percentage extraction using Mutanase was 36.36% at an enzyme concentration of 50 mg per ml.

The length of contact time between the enzyme and yeast cells was shown to effect the percentage of astaxanthin extracted from the cells. Maximum percentage extraction of pigment was obtained from the cells after 24 hours contact time irrespective of the enzyme concentration used (Figure 4.2.4). Once the enzyme concentration was increased the percentage of astaxanthin extracted from the cells decreased.

Percentage extraction was used to determine the effectiveness of a specific enzyme at digesting the cell walls of the yeast. SP 299 Mutanase was judged to be the most effective enzyme preparation tested on the basis of percentage extraction of astaxanthin from the cells. SP 299 Mutanase allowed 93.94% of pigment to be released from the cells. Lyticase allowed 80.44% of the pigment to be released, while Novozyme allowed 89.33% of pigment to be released.

Although SP 299 Mutanase was determined to be the most effective enzyme tested in terms of percentage extraction of pigment from the cells, this enzyme is not a standard catalogue item for Novo Bioindustries (the sole source), giving rise to uncertainty about its availability in large quantities. Enzyme treatment also adds significantly to processing costs. Consequently, an alternative breakage method was explored.

Figure 4.2.1 Percentage extraction of astaxanthin from *Phaffia rhodozyma* cells after treatment with Novozyme 234

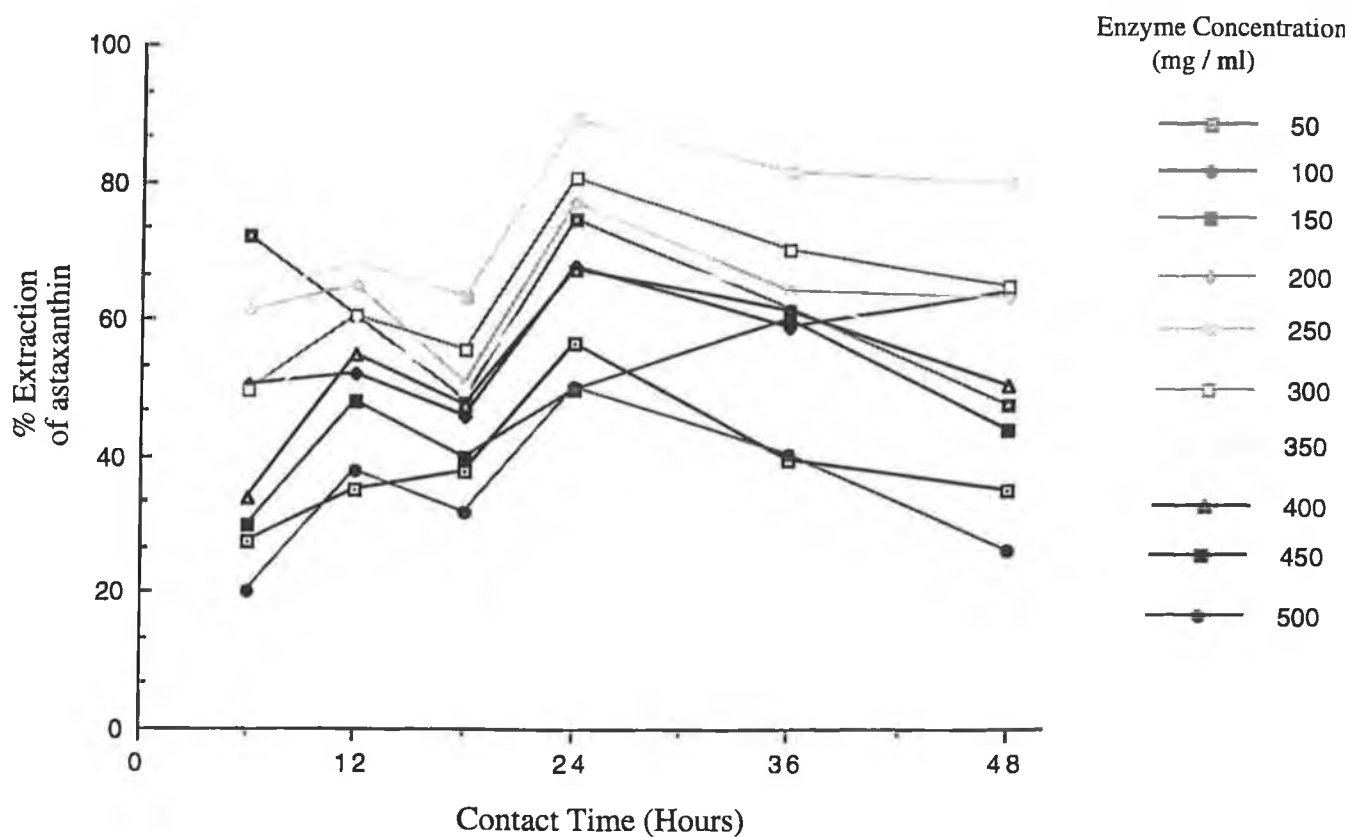

Figure 4.2.2 Percentage extraction of astaxanthin from *Phaffia rhodozyma* cells after treatment with Lyticase

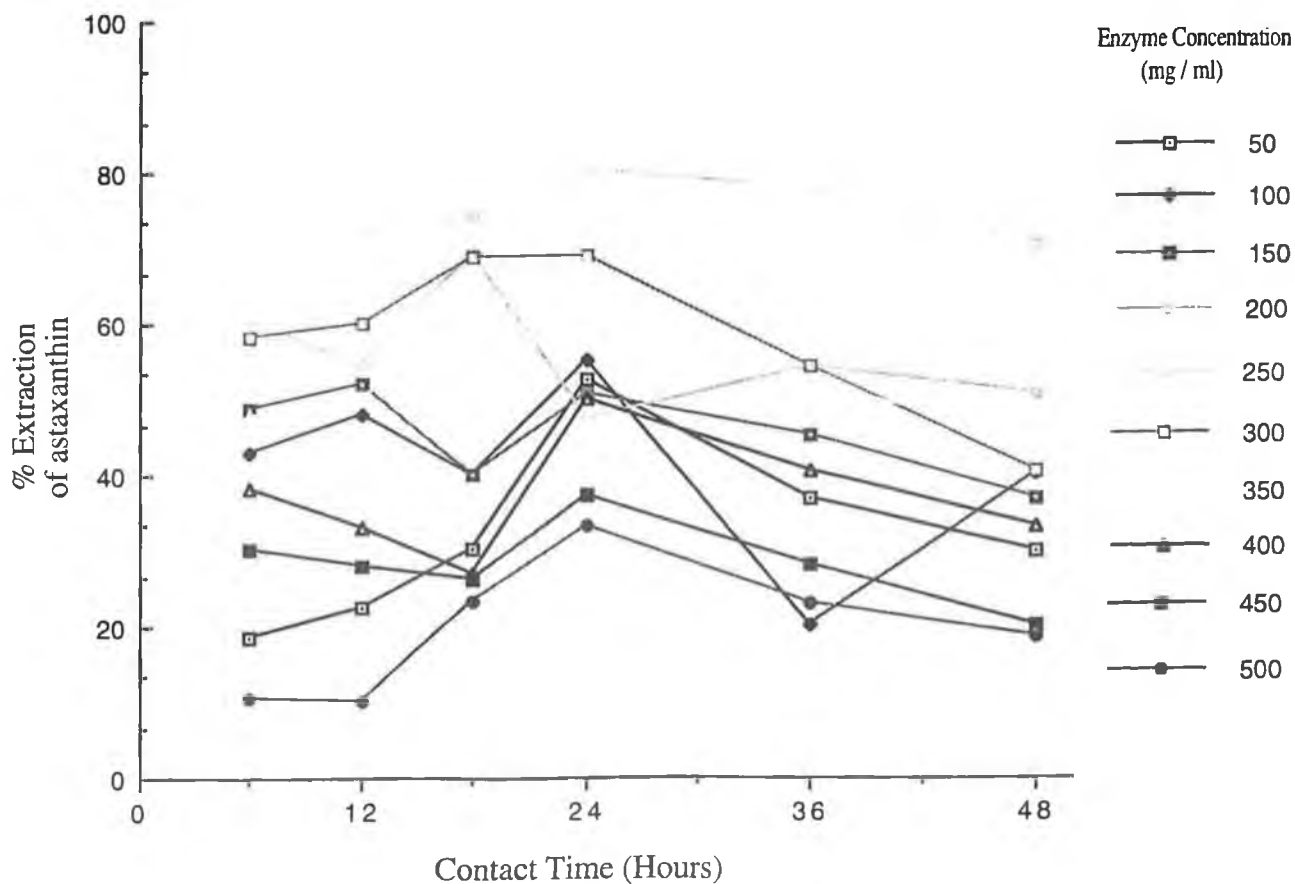

Figure 4.2.3 Percentage extraction of astaxanthin from *Phaffia rhodozyma* cells after treatment with SP 299 Mutanase

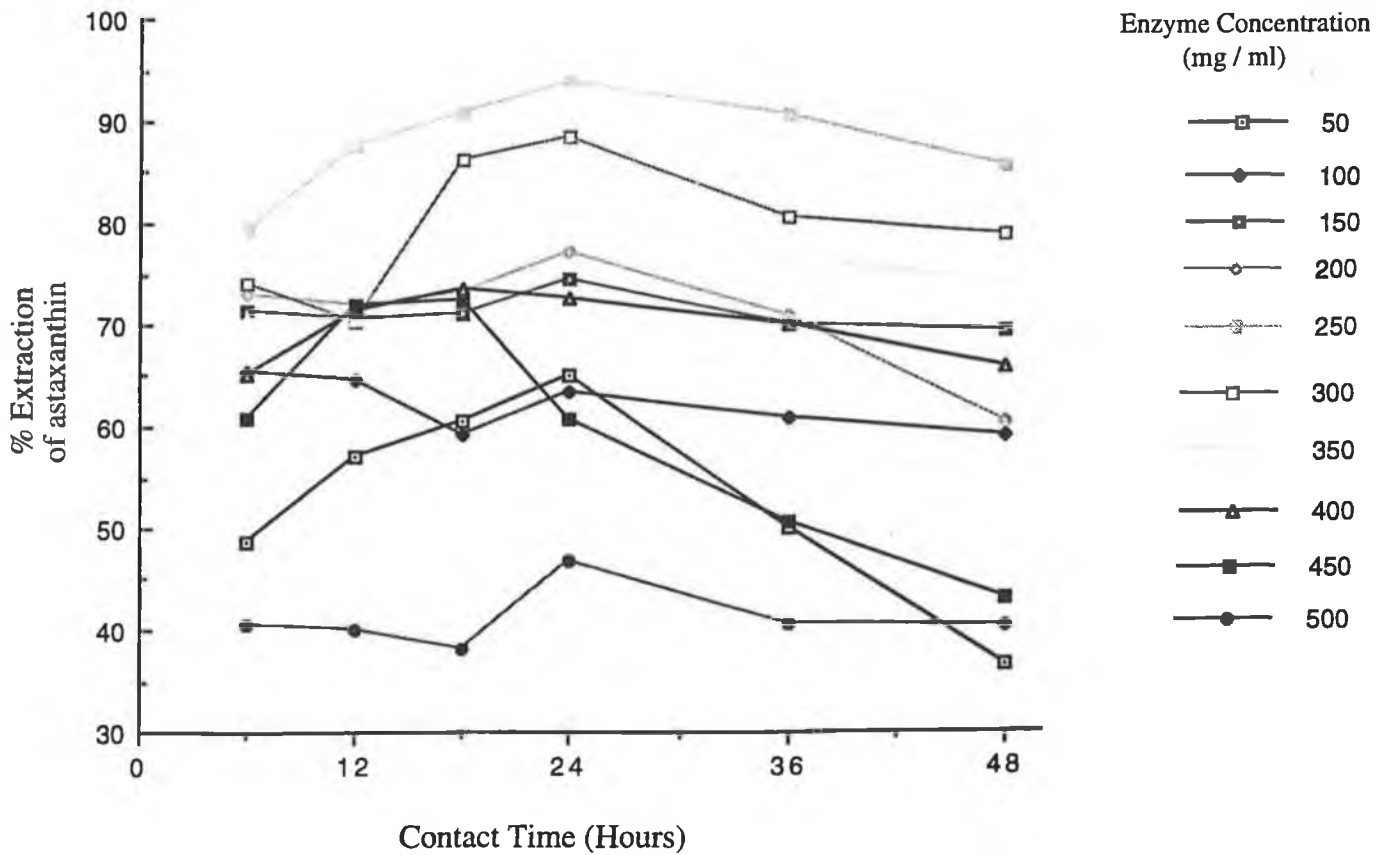
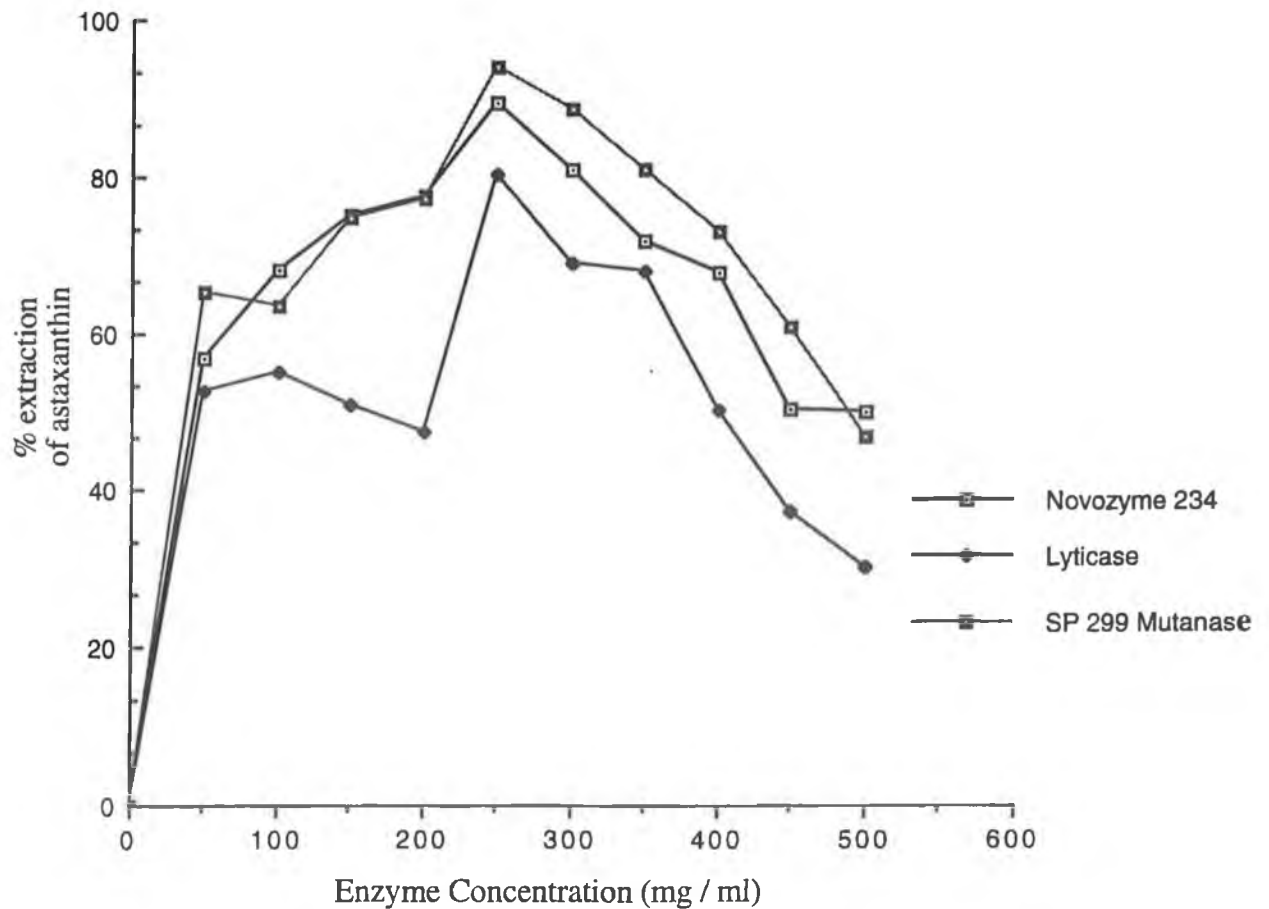

Figure 4.2.4 Percentage extraction of astaxanthin from *Phaffia rhodozyma* cells after enzyme treatment for 24 hours using three enzyme preparations



4.3 Treatment Of Yeast Cells Using Acid Lysis

Treatment with hot acid is a standard method for the hydrolysis of carbohydrate chains (Prevatt, W.D. 1991). While carotenoids containing epoxide groups are known to be heat labile, those lacking such structures (such as astaxanthin) are more resistant. A number of oxidative decompositions may result from the exposure of carotenoids to acids (Buchwald, M., and Jencks, W.P., 1968). The use of acids to pre-soften the cell wall of *Phaffia rhodozyma* has been carried out prior to mechanical breakage of the cells, and has been shown to render astaxanthin more extractable from the cells (Johnson *et al.* 1979) and Nelles *et al.* 1993). Pre-treatment of *Phaffia rhodozyma* cells with acids is acceptable practice, however, it is recommended that acids are contacted with the yeast cells for no less than 4 hours, and no longer than 48 hours, otherwise carotenoids may undergo oxidation (Nelles *et al.* 1993). It is also recommended that an acid concentrations above 2M are not used, as the carotenoids of *Phaffia rhodozyma* are degraded (Prevatt *et al.* 1991).

Several acids have been tested to determine if lysis of the cell wall of *Phaffia rhodozyma* would occur, allowing the release of pigment. Both sulphuric and hydrochloric acid have been shown to support significant breakage (Prevatt, W.D. 1991).

4.3.1 Analysis of Results

Acid treatment of *Phaffia rhodozyma* cells was investigated as a means of cell breakage. Sulphuric and hydrochloric acids were screened for their ability to degrade the cell walls of *Phaffia rhodozyma*. The maximum percentage extraction recorded was 31.33% obtained using 2M hydrochloric acid (Table 4.3.1). Maximum percentage breakage recorded using 2M sulphuric acid was 24.66%. Acid lysis was therefore determined to be an ineffective method of cell breakage.

Table 4.3.1 Percentage extraction of astaxanthin from *Phaffia rhodozyma* cells after acid lysis using hydrochloric and sulphuric acid

Temperature (°C)	Concentration of hydrochloric acid (M)	Percentage extraction of astaxanthin	Concentration of sulphuric acid (M)	Percentage extraction of astaxanthin
20	1M	5.68	1M	5.85
20	2M	10.94	2M	7.10
40	1M	15.91	1M	12.22
40	2M	20.66	2M	15.72
60	1M	18.75	1M	20.91
60	2M	31.33	2M	24.66
80	1M	14.62	1M	11.77
80	2M	10.19	2M	8.81

4.4 Acid Lysis and Enzyme Treatment of *Phaffia rhodozyma* Cells

Another approach used tested was to 'pre-soften' *Phaffia rhodozyma* cells with acid prior to enzyme treatment, to determine if cell breakage would occur. The cells were then treated with SP S99 Mutanase at a concentration of 250 mg / ml. Percentage extraction of pigment was determined as previously described in Chapter Three.

4.4.1 Analysis of Results

The success of the pre-treatment of *Phaffia rhodozyma* cells with hydrochloric acid prior to enzyme treatment with Mutanase proved to dependant on the length of contact time between the enzyme and yeast cells (Table 4.4.1.1). Maximum extraction of 98.24% was recorded using a 2M concentration of the acid, after 24 hours incubation at 60°C. At the lowest incubation temperature used, the highest percentage extraction recorded was 79.02%. This is 19.22% lower than the maximum percentage extraction obtained using this acid.

At an incubation temperature of 80°C, the highest percentage extraction recorded using hydrochloric acid and enzyme treatment was 65.41%, which is 32.83% lower than the maximum percentage extraction recorded using this acid. The high incubation temperature may have degraded the pigment,

resulting in low yields of astaxanthin and low extraction percentages. Maximum extraction using a combination of hydrochloric acid and enzyme treatment was 98.24%. This was 4.31% higher than the maximum percentage extraction recorded using enzyme treatment as the sole method of cell breakage (Table 4.4.1.1).

Table 4.4.1.1 Percentage extraction of pigment from *Phaffia rhodozyma* cells after hot acid lysis with hydrochloric and sulphuric acid followed by enzyme treatment with SP 299 Mutanase

Temperature (°C)	Concentration of HCL and H ₂ SO ₄ acid (M)	*Percentage of astaxanthin extracted from cells after HCL lysis and enzyme treatment	*Percentage of astxanthin extracted from cells after H ₂ SO ₄ lysis and enzyme treatment
20	0.5 M	73.33	32.63
20	1.0 M	74.90	46.67
20	2.0M	79.02	39.05
40	0.5 M	93.60	70.91
40	1.0 M	95.73	75.38
40	2.0 M	96.06	74.40
60	0.5 M	95.51	85.45
60	1.0 M	97.34	88.97
60	2.0 M	98.24	88.47
90	0.5 M	61.21	44.35
90	1.0 M	65.41	39.05
90	2.0 M	54.29	28.89

* Mean Value Of Triplicate Determinations

The percentage extraction values recorded using sulphuric acid to pre-treat the cells were lower than those obtained using hydrochloric acid (Table 4.4.1.1). At the lowest incubation temperature maximum extraction was 46.67%. At the highest incubation temperature the highest percentage extraction was 2.32% lower, at 44.35%. The high incubation temperature used may have caused the pigment to degrade, allowing only 44.35% of the pigment in the cells to be extracted.

Maximum extraction using a combination of sulphuric acid lysis and enzyme treatment was 88.97%, using a 2M concentration of acid at a temperature of 60°C. This is 9.27% lower than the maximum percentage extraction recorded using hydrochloric acid. Using sulphuric acid to pre-treat the cells followed by enzyme treatment with Mutanase is 88.97% effective, with a maximum extraction 4.97% lower than that obtained using enzyme treatment as the sole method of cell disintegration.

4.5 Comparison of Various Growth Media

Four different growth media were used to cultivate *Phaffia rhodozyma*, and these were: Rich Assay Growth Medium (RAGM), Johnson Lewis Mineral Salts Medium (MSM), Substitute Yeast Malt Broth (YS) and Yeast Malt Broth (YMB). The growth of the yeast in each medium was assessed by measuring the total cell count using the haemocytometer, and the viable cell count using the pour plate method. All viable and total cells counts given are the average results of triplicate determinations. The specific growth rate was calculated using these results and determined which medium supported the best growth of *Phaffia rhodozyma*.

4.5.1 Analysis of Results

The first medium used to culture *Phaffia rhodozyma* was a Rich Assay Growth Medium. When *Phaffia rhodozyma* was grown in a shake flask culture using this medium, the growth curve obtained using the viable cell counts shows exponential growth proceeding after a lag phase of 36 hours. Exponential growth lasted for 32 hours, with cells entering the stationary phase after 64 hours (Figure 4.5.1.1).

When *Phaffia rhodozyma* was grown in a shake flask culture using a Mineral Salts Medium, a lag phase of 24 hours can be observed (Figure 4.5.1.1). Exponential growth proceeded for the next 36 hours, with cells entering the stationary phase after 68 hours.

Using a substitute Yeast Malt Broth to culture *Phaffia rhodozyma*, a lag phase of 36 hours can be observed, after which time cells enter the exponential phase of growth (Figure 4.5.1.1). Cells remain in this phase of growth for 32 hours, entering the stationary phase after 68 hours.

When *Phaffia rhodozyma* was cultured in a Yeast Malt Broth, the growth curve obtained using the viable cell counts show a lag phase of 24 hours, with cells entering the exponential phase after this time. Cells remain in this growth phase for 48 hours, with stationary growth proceeding after 72 hours (Figure 4.5.1.1).

Figure 4.5.1.1 Growth curves for *Phaffia rhodozyma* grown in shake flask culture using various growth media (obtained using viable cell counts)

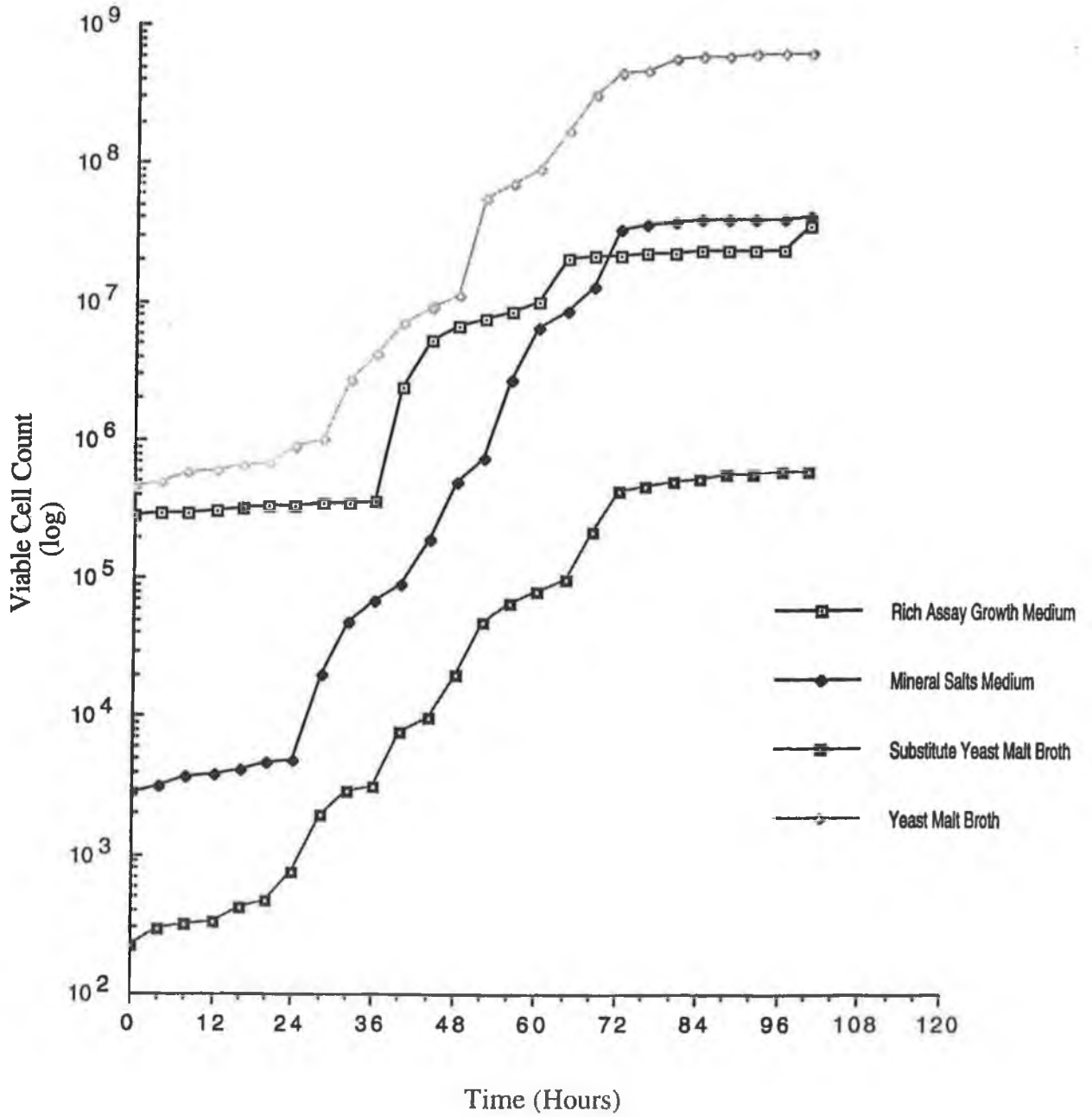
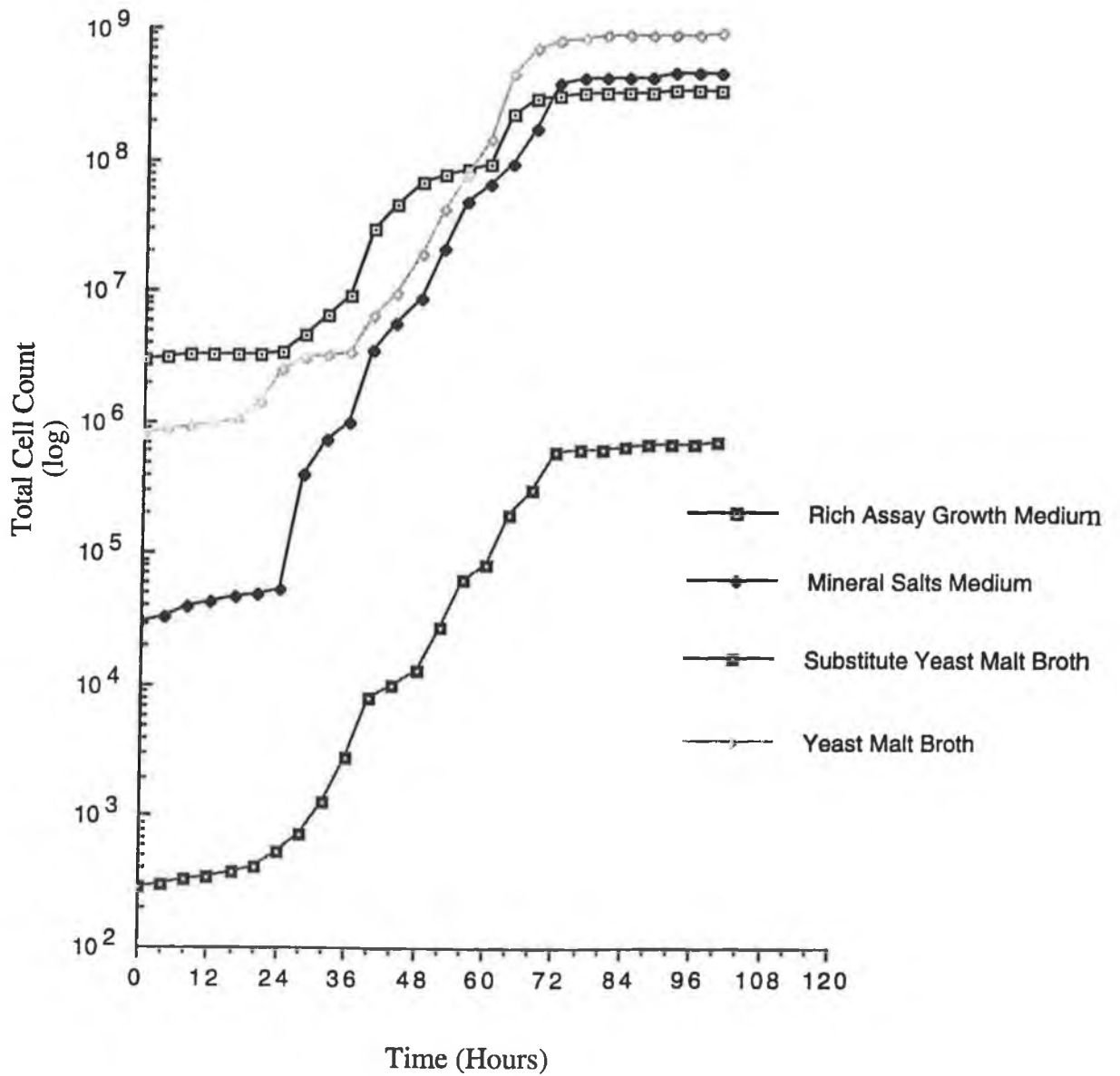

Figure 4.5.1.2 Growth curves for *Phaffia rhodozyma* grown in shake flask culture using various growth media (obtained using total cell counts)



The long lag phase and short exponential phase observed when *Phaffia rhodozyma* was cultured in the substitute Yeast Malt Broth and Rich Assay Growth Medium, could be due to the yeast cells taking longer to adapt to these growth media after transfer of the inoculating culture. Cells may have adapted more slowly, resulting in the shorter lag phase and longer exponential phase observed when *Phaffia rhodozyma* was grown in these two media.

The highest viable cell counts were recorded using the Yeast Malt Broth to culture the yeast, with a viable count of 6.06×10^8 cells per ml recorded after 100 hours of growth. The lowest viable cell counts were recorded using the substitute Yeast Malt Broth medium to culture the organism.

The growth curve obtained using the total cell counts show a lag phase of 24 hours (Figure 4.5.1.2). This is a shorter lag phase than that observed using the viable cell counts. After this time cells enter the exponential phase which lasts for 44 hours. This growth phase lasts 8 hours more than the exponential phase observed using the viable cell count results. Cells enter the stationary phase after 68 hours of growth.

Looking at the growth curve obtained when *Phaffia rhodozyma* was grown in a shake flask culture using the Mineral Salts Medium, a lag phase of 24 hours can be observed (Figure 4.5.1.2). Cells then enter the exponential phase which lasts for 44 hours. After 68 hours the cells enter the stationary phase.

When *Phaffia rhodozyma* was grown in a substitute Yeast Malt Broth a lag phase of 40 hours can be observed (Figure 4.5.1.2). This is the longest lag phase recorded using any of the media to culture the organism. Cells then entered the exponential growth phase which lasted for 32 hours. After 72 hours cells entered the stationary phase. The length of the lag phase observed using the total cell counts was 4 hours longer than the lag phase observed using the viable cell counts, when *Phaffia rhodozyma* was cultured in the substitute Yeast Malt Broth.

Looking at the growth curves obtained using the total cell counts when *Phaffia rhodozyma* was grown in a Yeast Malt Broth, a lag phase of 24 hours can be observed (Figure 4.5.1.2). After this time cells entered the exponential phase of growth which lasted for 48 hours. After 72 hours the cells enter the stationary phase. Comparing the two growth curves obtained using the viable

and total cell counts the same pattern can be observed, with the lag phase and exponential phase lasting for the same length of time. For example, when *Phaffia rhodozyma* was cultured in the Rich Assay Growth Medium and substitute Yeast Malt Broth, the growth curves obtained using the viable cell counts show a lag phase lasting 36 hours (Figure 4.5.1.1). The growth curves obtained using the total cell counts show a lag phase of only 24 hours (Figure 4.5.1.2).

Differences in the length of the exponential phase can also be seen, when comparing the growth curves obtained using the total and viable counts. For example, when *Phaffia rhodozyma* was cultured in a Mineral Salts Medium and a substitute Yeast Malt Broth, the growth curves obtained using the viable cell counts show an exponential phase lasting 36 hours (Figure 4.5.1.1). However, the growth curves obtained using the total cell counts show an exponential phase lasting 44 hours, when *Phaffia rhodozyma* was cultured in the Mineral Salts Medium, and an exponential phase lasting 36 hours, when *Phaffia rhodozyma* was cultured in the substitute Yeast Malt Broth (Figure 4.5.1.2).

Similarities between the growth curves obtained using both cell count results can also be seen. Looking at the growth curve obtained using the viable cell counts, a lag phase of 24 hours can be seen when *Phaffia rhodozyma* was cultured in the Mineral Salts Medium and Yeast Malt Broth (Figure 4.5.1.1). A lag phase of 24 hours can also be seen from the growth curves obtained using the total cell counts, when *Phaffia rhodozyma* was cultured in these two media (Figure 4.5.1.2). When *Phaffia rhodozyma* was grown in the Yeast Broth Medium, the growth curves obtained using both total and viable counts show exponential growth lasting for 44 hours.

The highest total cell counts were recorded using the Yeast Malt Broth to culture the organism, with a total cell count of 8.98×10^8 cells per ml recorded after 100 hours of growth. The lowest total cell counts were recorded using the substitute Yeast Malt Broth to culture the organism.

The specific growth rate (μ) was calculated using the total and viable cell counts recorded when *Phaffia rhodozyma* was grown in the various media. The media which supported the best growth of *Phaffia rhodozyma* were determined using these results. The highest mean specific growth rate recorded was $0.185 \mu / \text{hr}^{-1}$ using a Mineral Salts Medium to culture the organism (Table 4.5.1.1).

The second highest mean specific growth rate recorded was $0.170 \mu / \text{hr}^{-1}$ using a Yeast Malt Broth to culture the organism.

Table 4.5.1.1 Specific growth rates obtained for *Phaffia rhodozyma* cultured in various growth media

Medium Used	Specific Growth Rate (μ / Hour^{-1})		
	Calculated from Total Cell Counts	Calculated from Viable Cell Counts	Mean μ Value (μ / hr^{-1})
Rich Assay	0.11	0.13	0.120
Mineral Salts	0.19	0.18	0.185
Substitute Yeast Malt	0.15	0.14	0.145
Yeast Malt Broth	0.16	0.18	0.170

The two lowest mean specific growth rates were recorded using the substitute Yeast Malt Broth and the Rich Assay Growth Medium to culture the organism.

Subsequent research carried out in this project looked at biomass and pigment production by *Phaffia rhodozyma*. The Yeast Malt Broth and Mineral Salts Medium were the growth media chosen to culture the organism in these experiments, as the yeast grew best in these two media.

4.6 Cultivation of the parent strain (NCYC 874) and a mutant strain (NRRL-Y-18734) of *Phaffia rhodozyma* in shake flask culture

4.6.1 Introduction

The main area of interest in this research involves the optimisation of biomass and pigment production by *Phaffia rhodozyma*. A first step in this direction involved culturing the parent strain and a mutant strain of the yeast in a batch system using shake flasks and monitoring growth, pigment and biomass production, and consumption of the carbon and nitrogen sources by the yeast.

4.6.2 Analysis of Results

The results for biomass and astaxanthin production, utilisation of the carbon and nitrogen sources and growth of *Phaffia rhodozyma* for each run were collated and the results presented.

The average yields of biomass produced by the parent strain grown in a Yeast Malt Broth and a Mineral Salts Medium are presented in Figure 4.6.2.1 .

The biomass yields produced by the parent strain of *Phaffia rhodozyma* cultured in a yeast malt broth and mineral salts medium are shown together with the range of error for the mean calculated at the 95 % confidence level. Looking at the average yields produced by the parent strain cultured in the yeast malt broth, it can be observed that biomass production increases up to 120 hours with maximum biomass production occurring at this time. A maximum average yield of 234 mg per 25 mls culture fluid was recorded at this time. After 120 hours of growth, the yields of biomass produced by the yeast begins to decrease. Biomass production increases after a lag phase of 24 hours, and cells remain in the exponential phase of growth until 120 hours, after which time they enter the stationary phase and biomass yields begin to decrease. Biomass production by the parent strain cultured in a mineral salts medium follows the same pattern. Biomass yields produced by the cells increases up to 120 hours, and once cells enter the stationary phase of growth yields decrease.

Astaxanthin production by *Phaffia rhodozyma* follows a similar pattern to that observed with biomass production. Pigment yields produced by the parent

strain cultured in the yeast malt broth and mineral salts medium, are shown in Figure 4.6.2.2 . Pigment production by the parent strain can be observed to follow the same pattern irrespective of which growth medium was used. Yields of pigment produced increased up to 120 hours of growth when maximum pigment production was recorded. Between 96 and 120 hours of growth there is a two fold increase in pigment yield by the cells when the yeast malt broth was the growth medium used. After this time pigment production decreases. Research has shown that the production of biomass and pigment by *Phaffia rhodozyma* is linked (Johnson *et al.* 1979), it would therefore be expected that as pigment yields fall, there would be a corresponding decrease in biomass production.

From these results it appears that production of pigment and biomass by the parent strain of *Phaffia rhodozyma* follows a similar pattern. As the levels of biomass produced by the yeast increases, so does pigment production. After 120 hours of growth biomass and pigment production by the parent strain is at a maximum and after this time yields of pigment and biomass produced by the cells begins to decrease.

The average optical density results recorded during the cultivation of *Phaffia* in both of the growth media used, are shown in Figure 4.6.2.3 together with the range of error calculated at the 95% confidence level.

It can be observed that the optical density measurements recorded during the cultivation of the organism increase over 240 hours. Even though the levels of pigment and biomass produced by the yeast decrease after 120 hours the growth of the yeast (as measured by optical density) continues after this time. Looking at the result for growth obtained using the yeast malt broth to culture the yeast, it can be observed that after an initial lag phase of 24 hours cells begin to grow exponentially. Once cells enter the stationary phase after 120 hours growth remains constant. It would be expected that a decrease in biomass and pigment yields would occur with a corresponding decrease in cell numbers, however cell numbers do not decrease even though the biomass and pigment yields have fallen.

The growth of the parent strain when cultured in the mineral salts medium follows the same pattern observed previously. Cell numbers increase up to 120 hours with growth remaining constant after this time.

Figure 4.6.2.1 Yields of biomass produced by the parent strain (NCYC 874) of *Phaffia rhodozyma* grown in shake flask culture using a Yeast Malt Broth and a Mineral Salts Medium

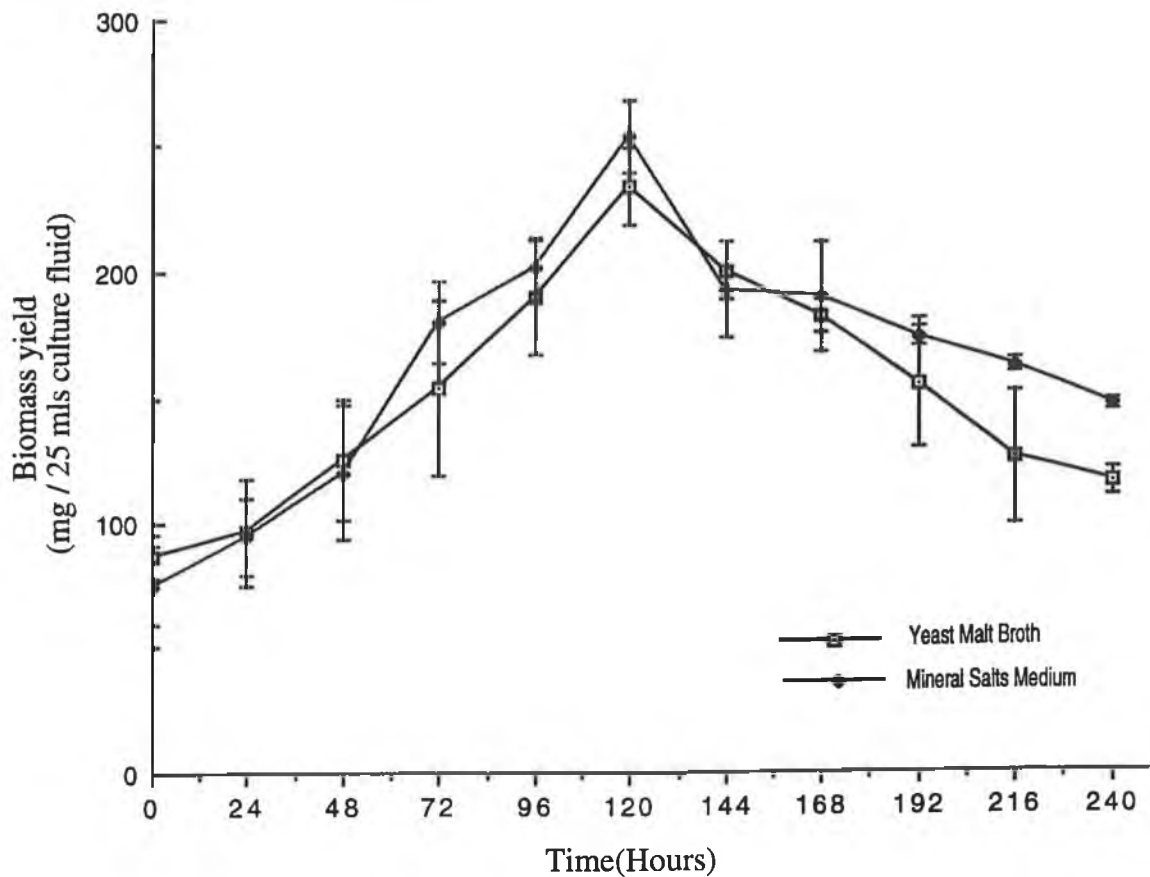

Figure 4.6.2.2 Pigment yields produced by the parent strain (NCYC 874) of *Phaffia rhodozyma* grown in shake flask culture using a Yeast Malt Broth and a Mineral Salts Medium

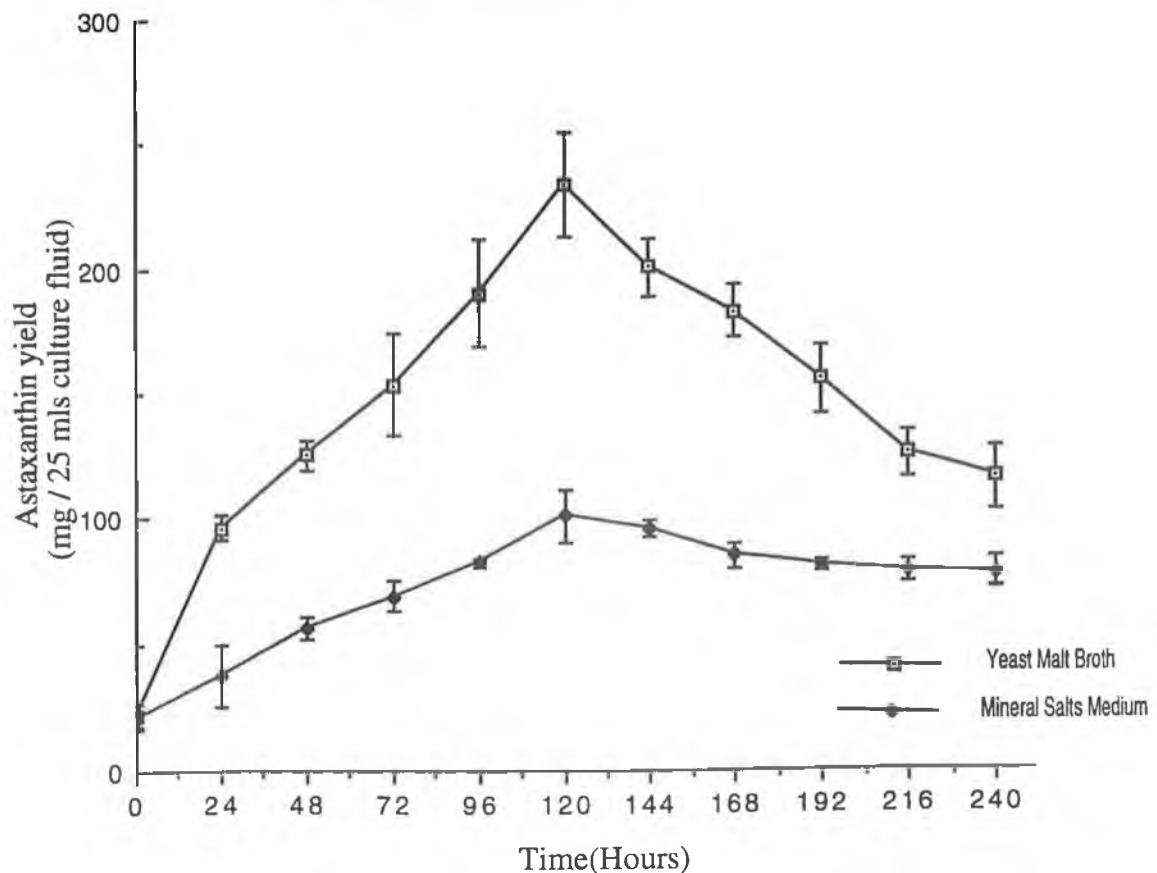
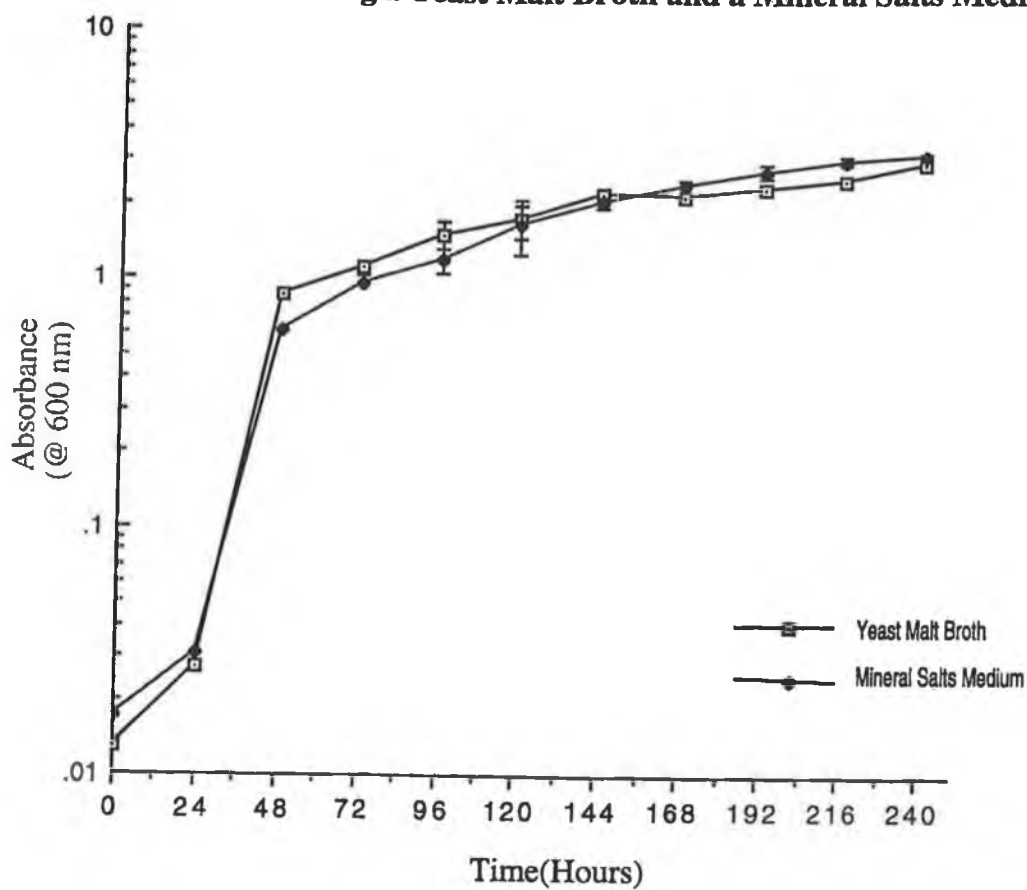

Figure 4.6.2.3 Growth of the parent strain (NCYC 874) of *Phaffia rhodozyma* grown in shake flask culture using a Yeast Malt Broth and a Mineral Salts Medium



The utilisation of the carbon source by the parent strain of the yeast was also investigated. Glucose usage by the parent strain when *Phaffia* was cultured in the yeast malt broth and mineral salts medium is shown in Figure 4.6.2.4. The range of error calculated at the 95% confidence level was too small to register on the computer, therefore error bars are not shown on the graph.

Utilisation of the carbon source by the parent strain cultured in the yeast malt broth proceeds at a rapid rate for the first 48 hours of growth after which time the rate of consumption slows. Maximum biomass and pigment yields are produced by the cells after 120 of growth, yet only 0.993 mg per ml glucose remains in the growth medium after 72 hours.

Looking at glucose consumption by the parent strain cultured in the mineral salts medium, the same pattern can be observed. As cells enter the exponential phase of growth, which occurs after 24 hours, glucose usage is very rapid. After 72 hours of growth, 0.986 mg / ml glucose remains in the growth medium. Even though pigment and biomass production increases for the next 48 hours, just 0.117 mg / ml of the carbon source is consumed. If the results for glucose consumption are shown in terms of the percentage glucose remaining in the growth medium, the pattern of glucose consumption by the parent strain becomes very clear (Figure 4.6.2.5).

After the first 24 hours of growth by the parent strain when cultured in the yeast malt broth, there is 52.69% of the carbon source remaining in the medium. This falls to just 9.81% over the next 24 hours. As the yields of biomass produced by the yeast increases the levels of glucose remaining in the growth medium decreases (Figure 4.6.2.6). This pattern is also observed with pigment production. As pigment production increases, glucose consumption also increases, and the levels of glucose remaining in the growth medium decreases (Figure 4.6.2.7). The increase in cell numbers (as measured by optical density) also increases in line with the consumption of the carbon source (Figure 4.6.2.8). After 144 hours of growth 5.09% of the carbon source remains. Over the next 90 hours this falls by just one percent.

Figure 4.6.2.4 Glucose consumption by the parent strain (NCYC 874) of *Phaffia rhodozyma* grown in shake flask culture using a Yeast Malt Broth and Mineral Salts Medium

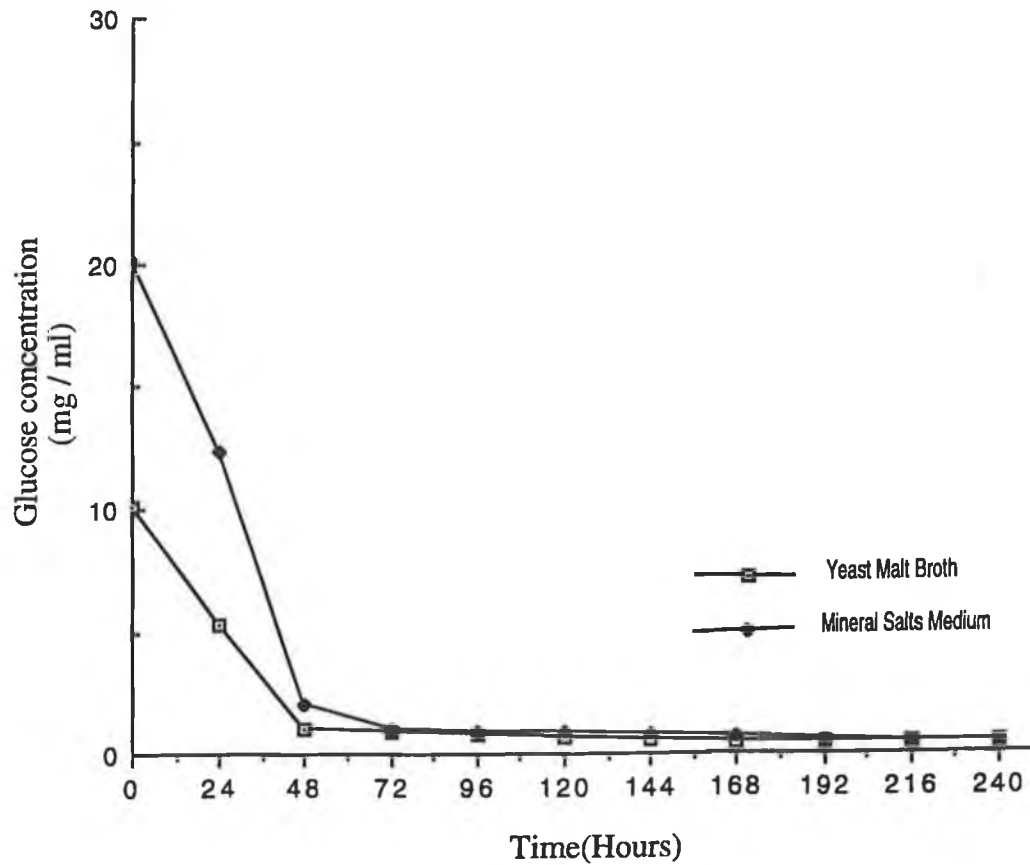

Figure 4.6.2.5 Percentage of the carbon source remaining in the growth medium after ten days growth of the parent strain (NCYC 874) of *Phaffia rhodozyma* in shake flask culture

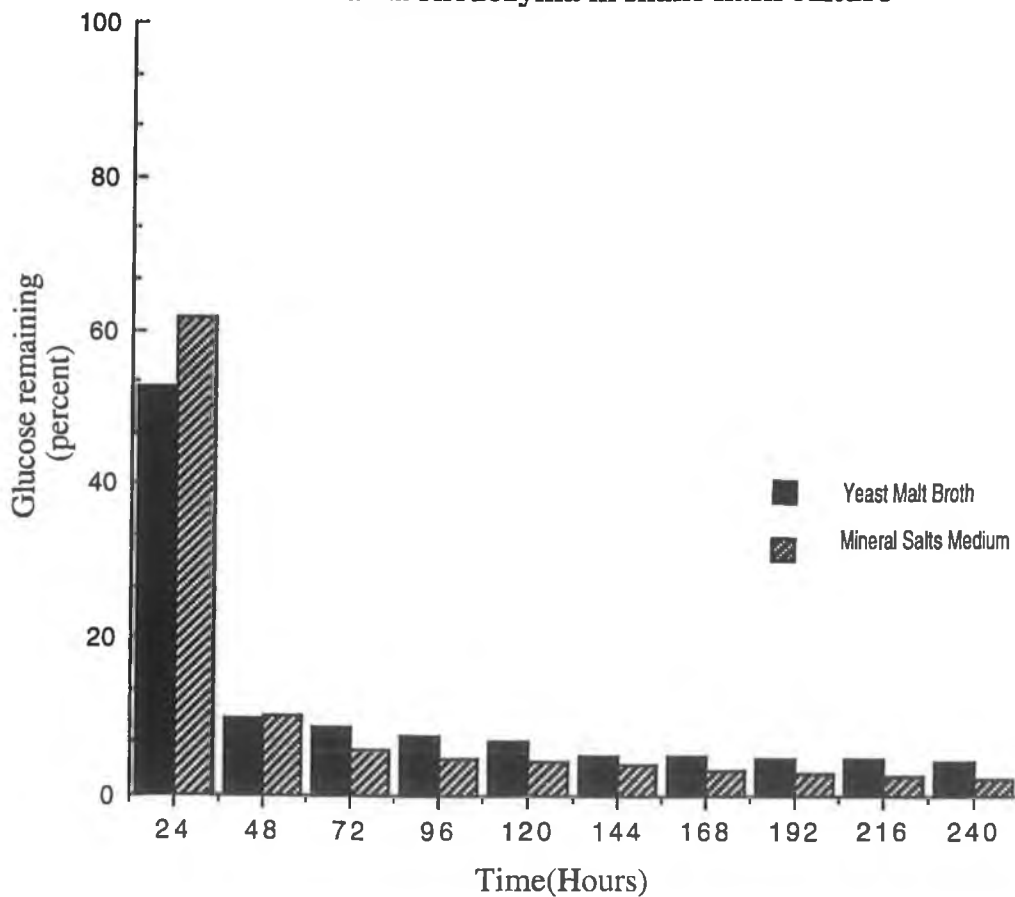

Figure 4.6.2.6 Biomass production and substrate consumption by the parent strain (NCYC 874) of *Phaffia rhodozyma* grown in shake flask culture using a Yeast Malt Broth

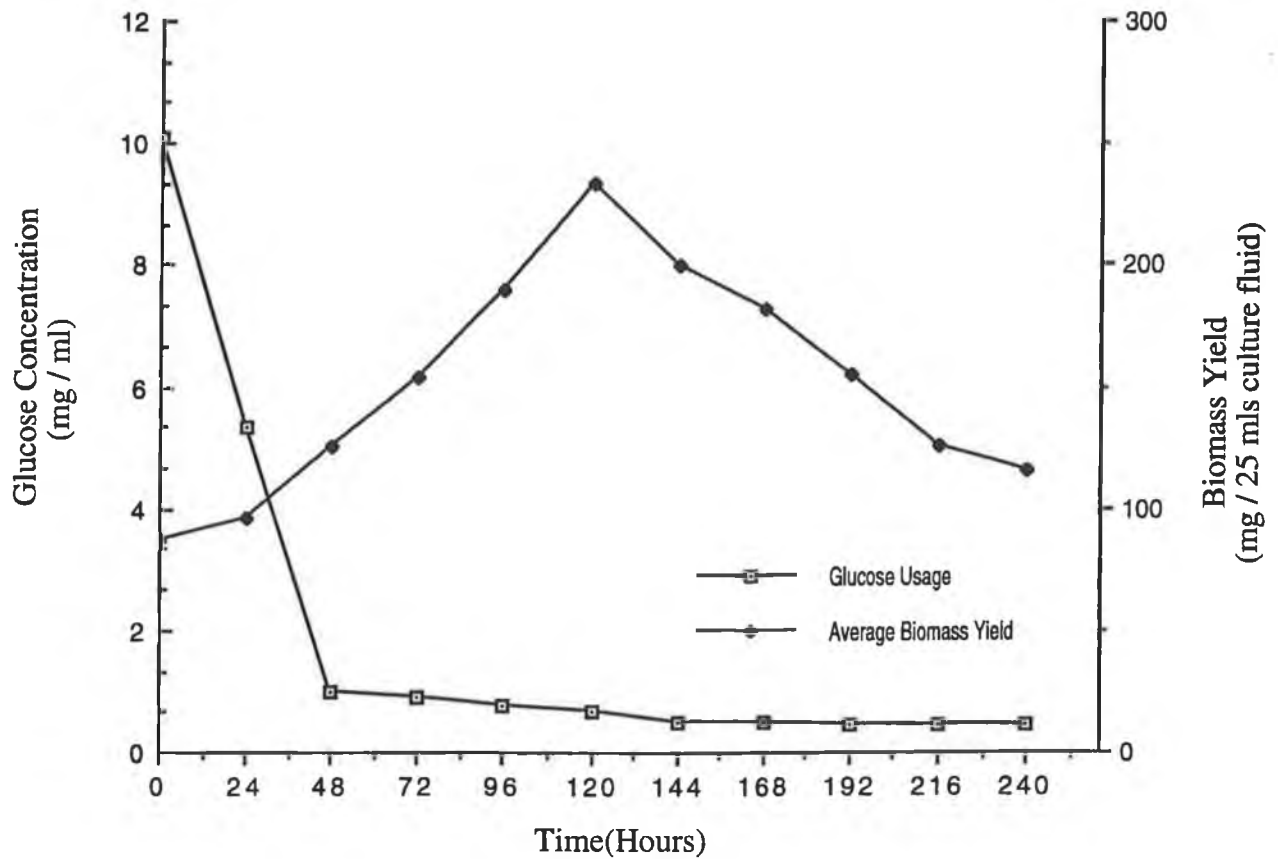

Figure 4.6.2.7 Pigment production and substrate consumption by the parent strain (NCYC 874) of *Phaffia rhodozyma* grown in shake flask culture using a Yeast Malt Broth

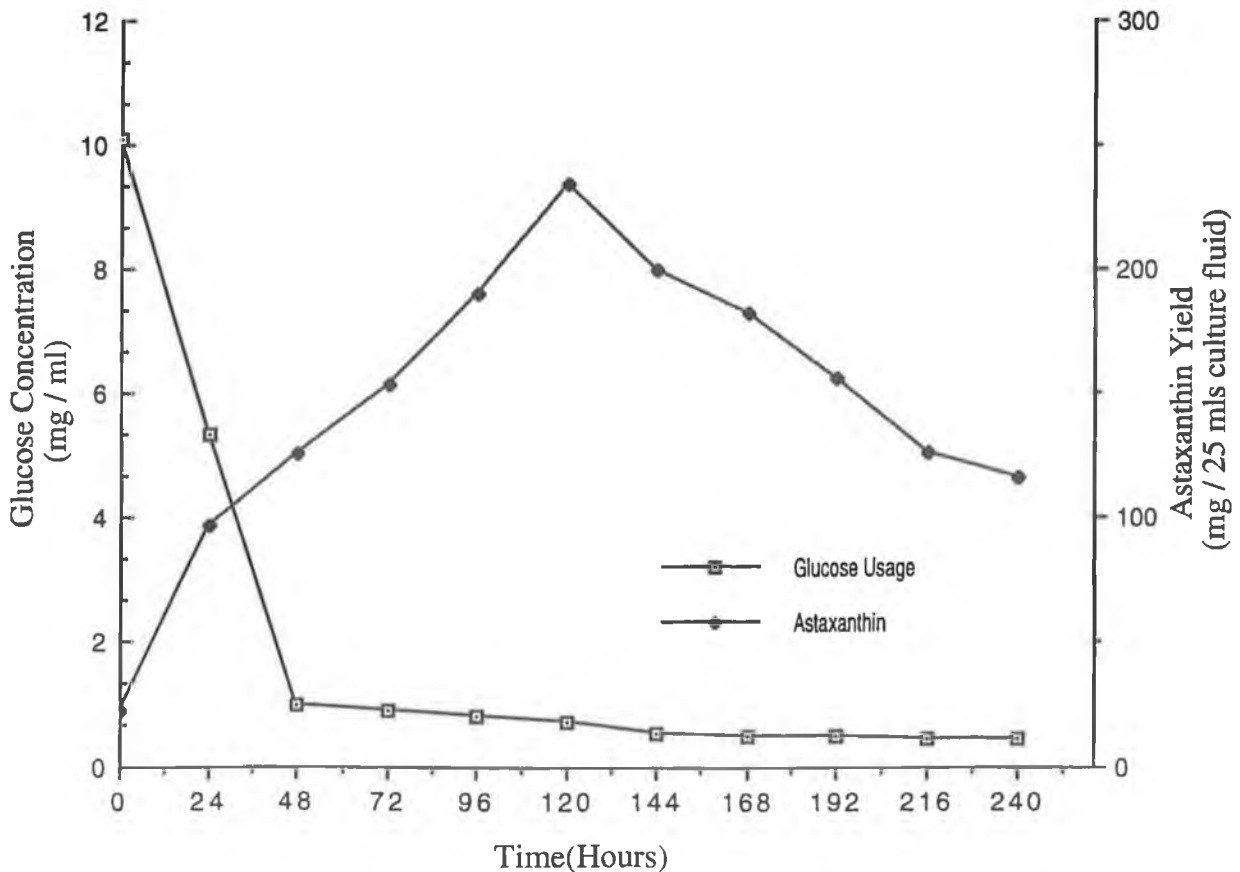
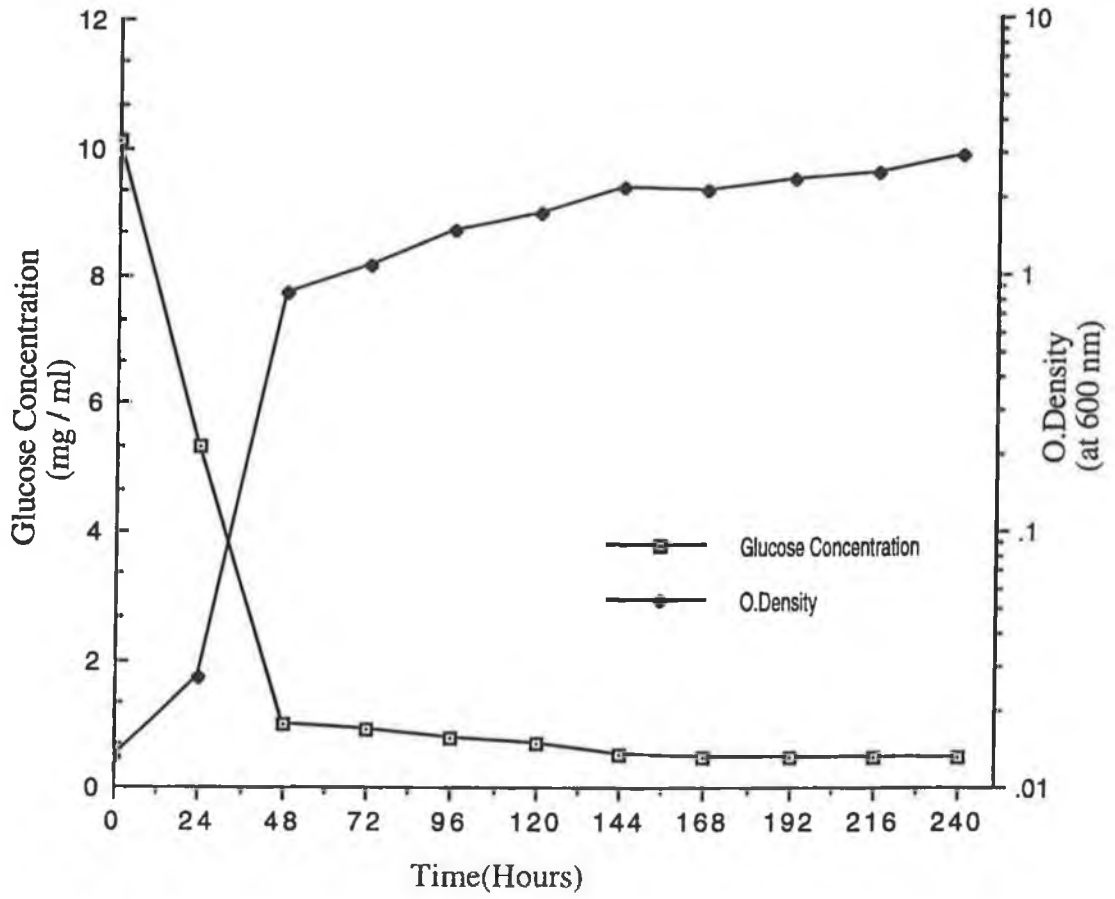

Figure 4.6.2.8 Growth and substrate consumption by the parent strain (NCYC 874) of *Phaffia rhodozyma* grown in shake flask culture using a Yeast Malt Broth



Glucose consumption by the parent strain when cultured in a mineral salts medium, follows the same pattern as previously observed. During the first 24 hours of growth, 61.58% of the carbon source remains in the growth medium. As the yields of both biomass and pigment produced by the cells increases, the levels of glucose remaining in the medium decreases (see Figures 4.6.2.9 and 4.6.2.10).

The increase in cell numbers (as measured by optical density) also increased in line with the utilisation of the carbon source (Figure 4.6.2.11). After 144 hours of growth, 3.80% of the carbon remains in the growth medium. This mirrors the pattern of glucose usage observed for the parent strain when cultured in a yeast malt broth. After 144 hours of growth, glucose usage slows down, with only 1% of the carbon source being consumed during the next 96 hours. Biomass and pigment yields produced by the yeast have fallen at this time, leading to a corresponding decrease in the consumption of the carbon source. Research has shown that an accumulation of glucose can lead to a fall in astaxanthin yields produced by the yeast cells (Johnson *et al.* 1991). However, it can be seen from the results obtained here, that over 96% of the carbon source was used by the parent strain during the first 72 to 96 hours of growth, when astaxanthin was yields produced by the cells increased. This meant that there was no accumulation of glucose in the growth medium, which would have had a detrimental affect on pigment production.

Where the parent strain was cultured in a batch system, astaxanthin and biomass production by the yeast followed a definite pattern, as did growth and consumption of the carbon and nitrogen sources, irrespective of which growth medium was used to culture the yeast.

The utilisation of the nitrogen source by the parent strain of *Phaffia rhodozyma* was also investigated. The pattern of nitrogen consumption when the yeast malt broth was the growth medium used, is shown in Figure 4.6.2.12, together with the range of error for the mean calculated at the 95% confidence level.

It can be observed that there is steady removal of the nitrogen source over 240 hours, when the mineral salts medium was used to culture the organism, as the available nitrogen in the medium decreases during the growth period.

Figure 4.6.2.9 Biomass production and substrate consumption by the parent strain (NCYC 874) of *Phaffia rhodozyma* grown in shake flask culture using a Mineral Salts Medium

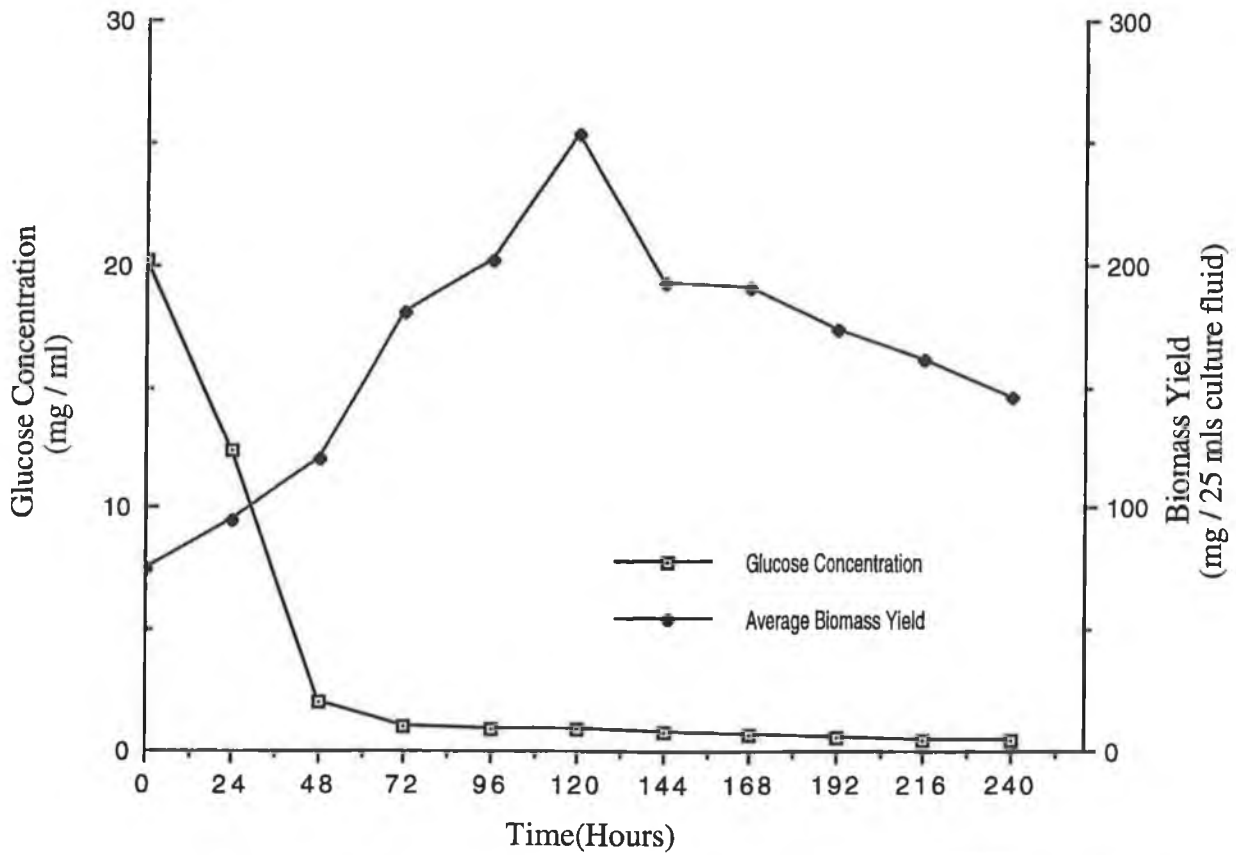

Figure 4.6.2.10 Astaxanthin production and substrate consumption by the parent strain (NCYC 874) of *Phaffia rhodozyma* grown in shake flask culture using a Mineral Salts Medium

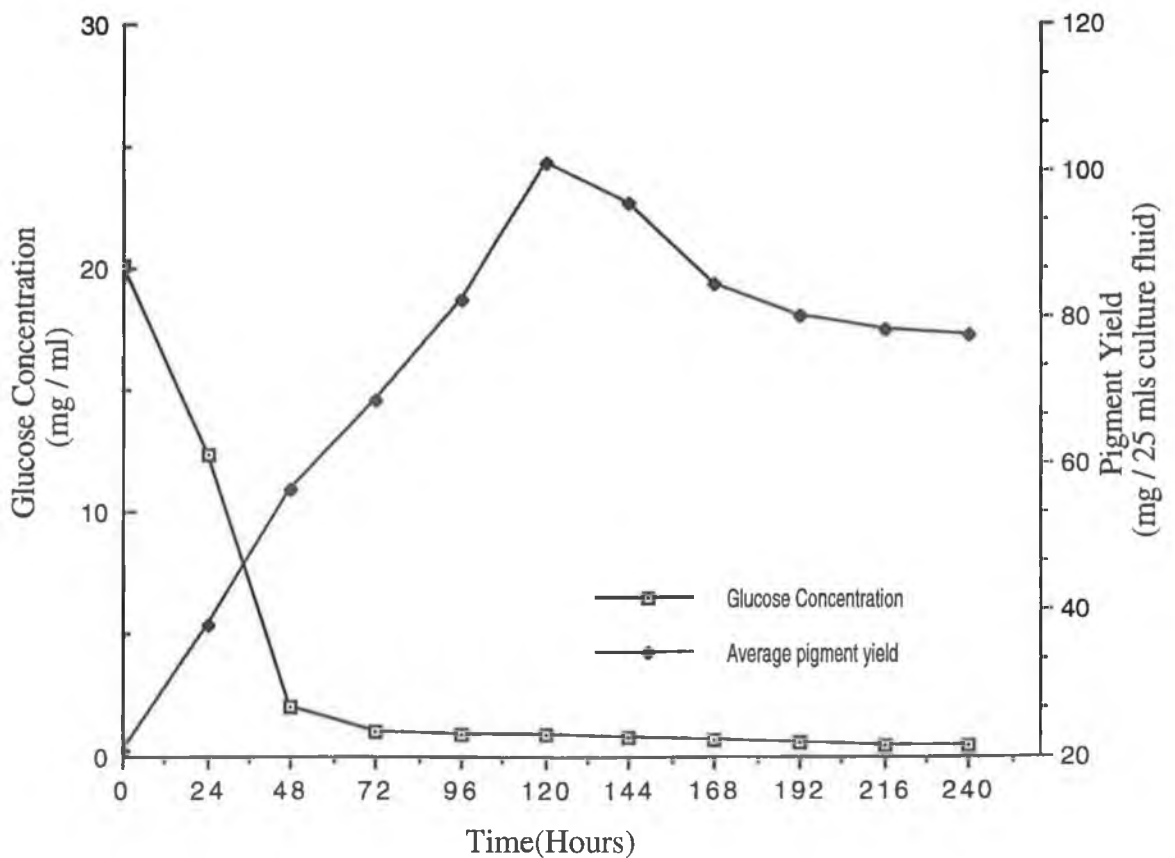
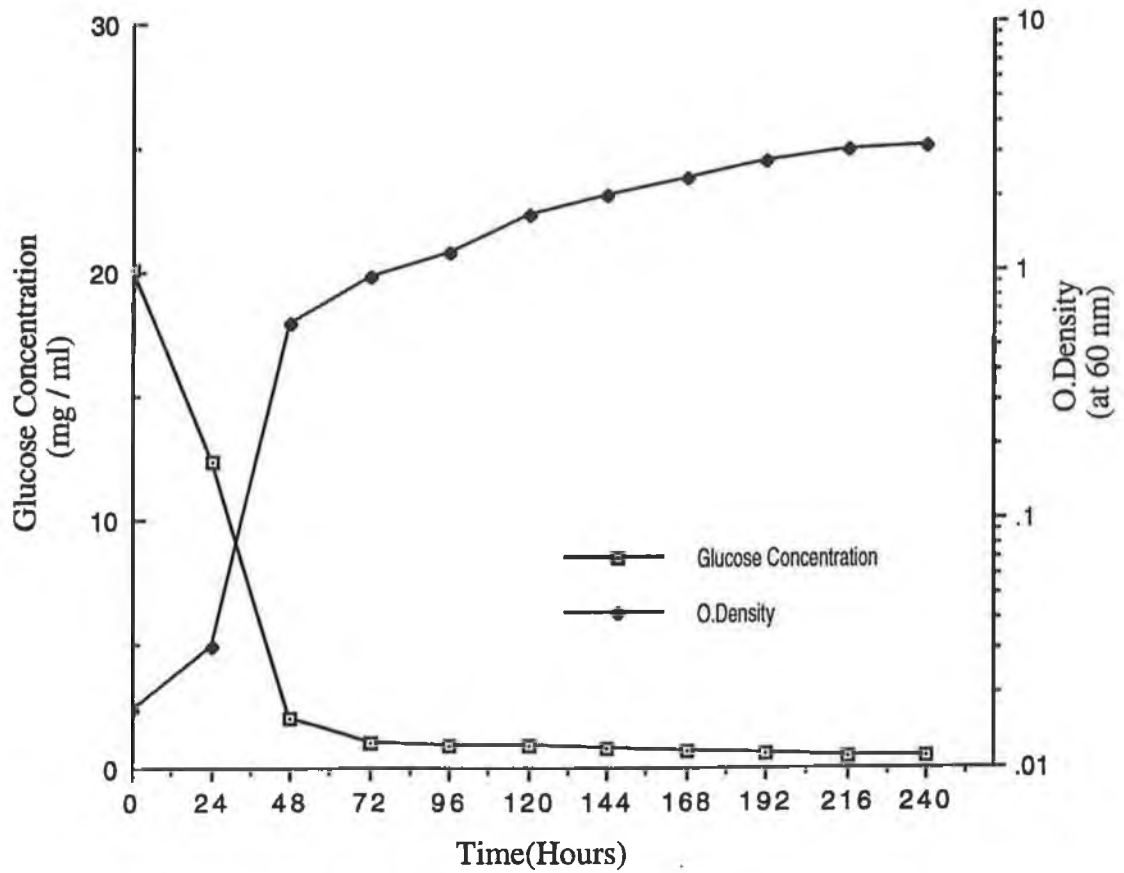

Figure 4.6.2.11 Growth and substrate consumption pattern of the parent strain (NCYC 874) of *Phaffia rhodozyma* grown in shake flask culture using a Mineral Salts Medium



Even though there is a decrease in biomass (Figure 4.6.2.13) and pigment production (Figure 4.6.2.14) by the parent strain after 120 hours of growth, nitrogen continues to be utilised, as does the carbon source. The same pattern can be observed for cell growth and nitrogen consumption (Figure 4.6.2.15).

If the results for nitrogen consumption are shown in terms of percentage of the nitrogen source remaining in the growth medium, the disappearance of nitrogen can be clearly observed (Figure 4.6.2.16).

Consumption of the nitrogen source by the parent strain of *Phaffia rhodozyma* follows a different pattern to that observed for the carbon source. Consumption of the nitrogen source occurs at a steady rate with 62.40% of the nitrogen source remaining in the growth medium after 72 hours. After this time only 59% of the carbon source remains. Even though the yields of both pigment and biomass produced by the parent strain increases after 120 hours, consumption of nitrogen continues steadily after this time. During the last 120 hours of growth 8.93% of the nitrogen source is consumed by the yeast. During the same period of time the percentage glucose remaining in the medium falls to just 1.99%. The rapid consumption of glucose by the parent strain over the first 120 hours of growth means that just 4.30% of the carbon source remains is available to the yeast after this time, therefore the percentage remaining in the growth medium would not be expected to decrease rapidly after this time.

42.11% of the nitrogen source remains in the growth medium after 120 hours, and a steady decrease of just 1.15 to 2.36% occurs every 24 hour period up to 240 hours. This is to be expected since the yields of biomass and pigment produced by the yeast have decreased during this time.

The results obtained here indicate that nitrogen consumption by the parent strain of *Phaffia rhodozyma* is at a maximum as the yields of pigment and biomass produced by the yeast are increasing. As the yields produced by the cells falls, so does the consumption of the nitrogen source.

Figure 4.6.2.12 Nitrogen consumption by the parent strain (NCYC 874) and a mutant strain (NRRL-Y-18734) of *Phaffia rhodozyma* grown in shake flask culture

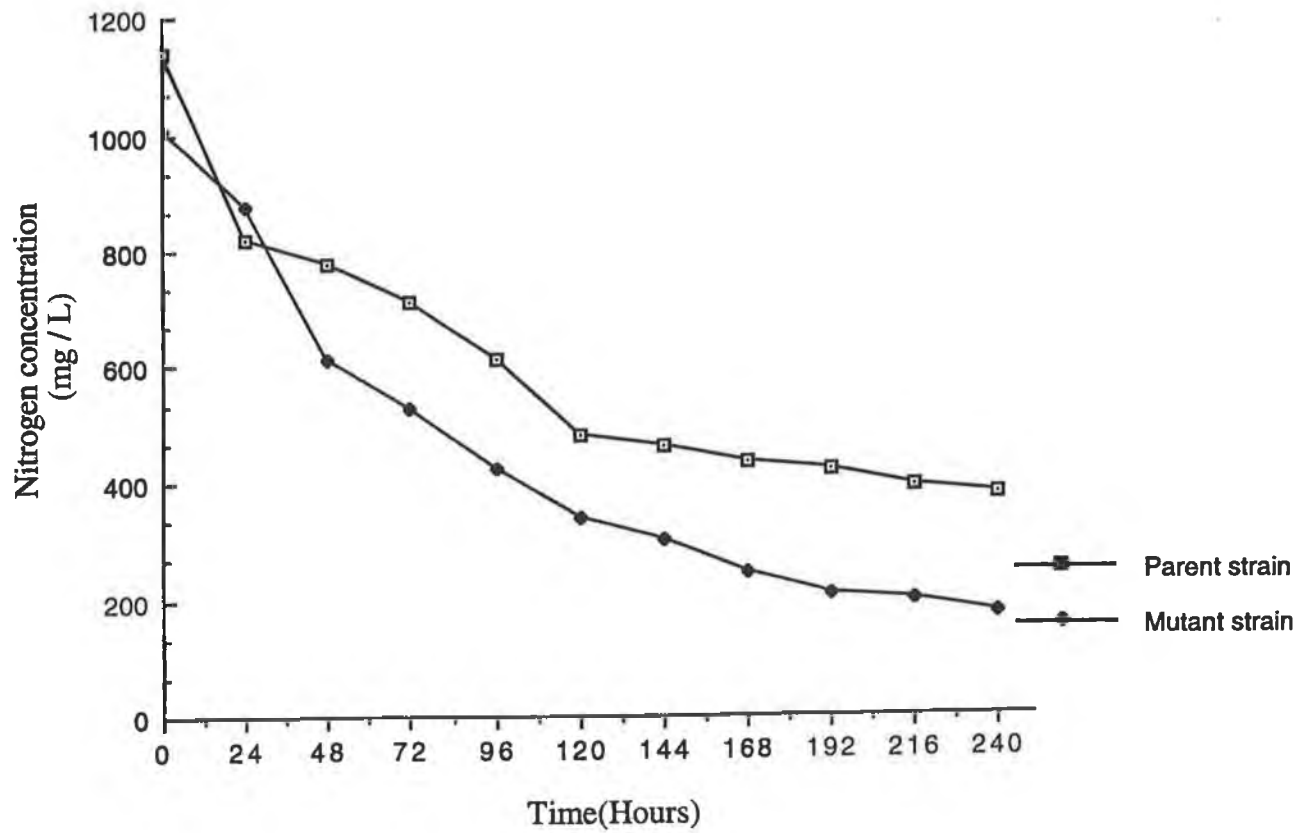

Figure 4.6.2.13 Biomass production and nitrogen consumption by the parent strain (NCYC 874) of *Phaffia rhodozyma* grown in shake flask culture using a Mineral Salts Medium

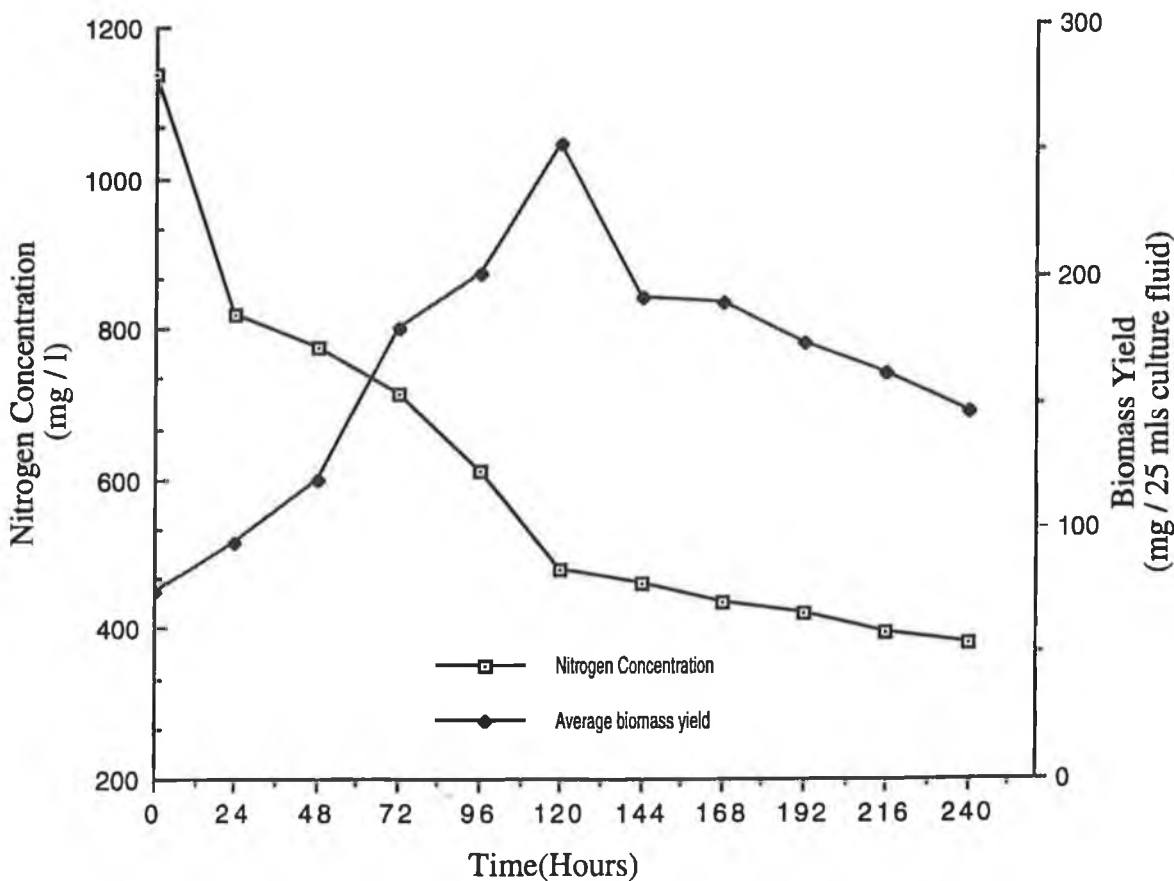

Figure 4.6.2.14 Pigment production and nitrogen consumption by the parent strain (NCYC 874) of *Phaffia rhodozyma* grown in shake flask culture using a Mineral Salts Medium

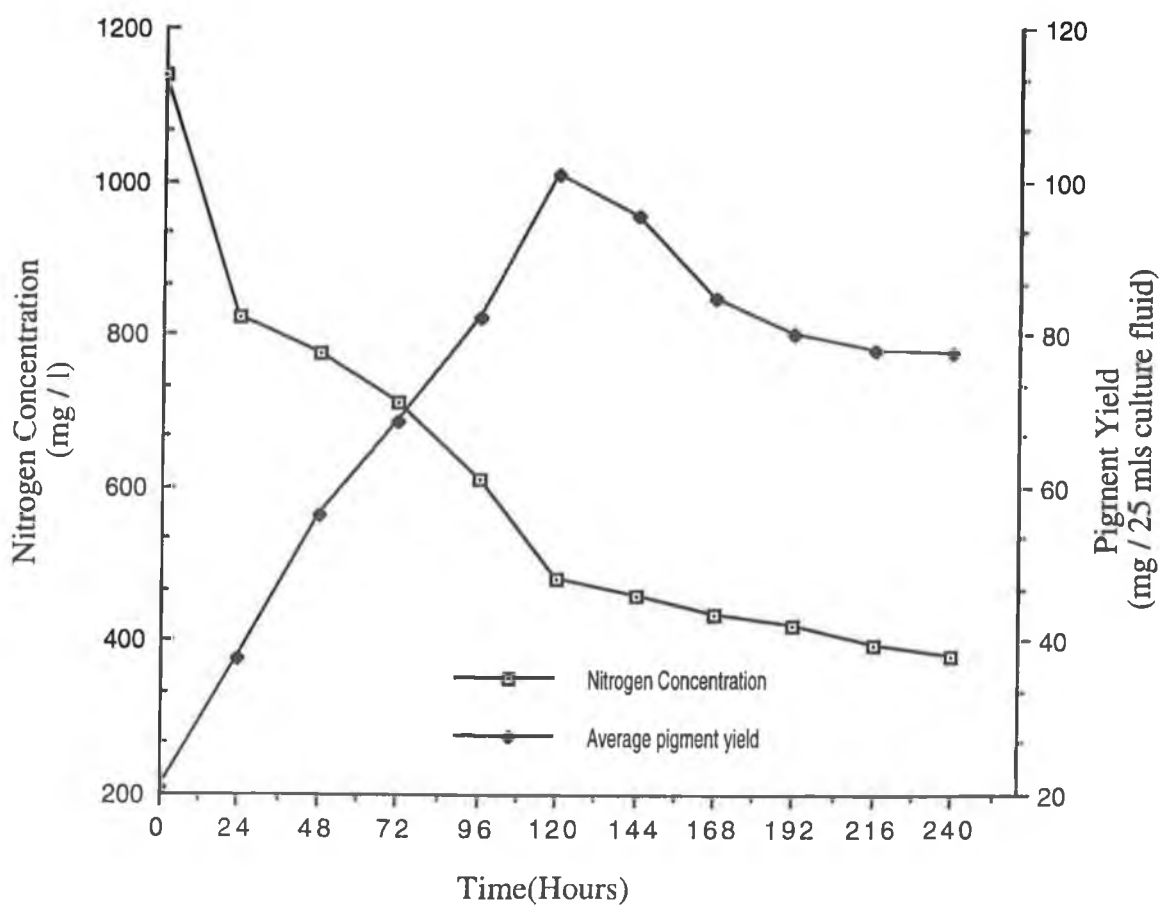

Figure 4.6.2.15 Growth and nitrogen consumption by the parent strain (NCYC 874) of *Phaffia rhodozyma* grown in shake flask culture using a Mineral Salts Medium

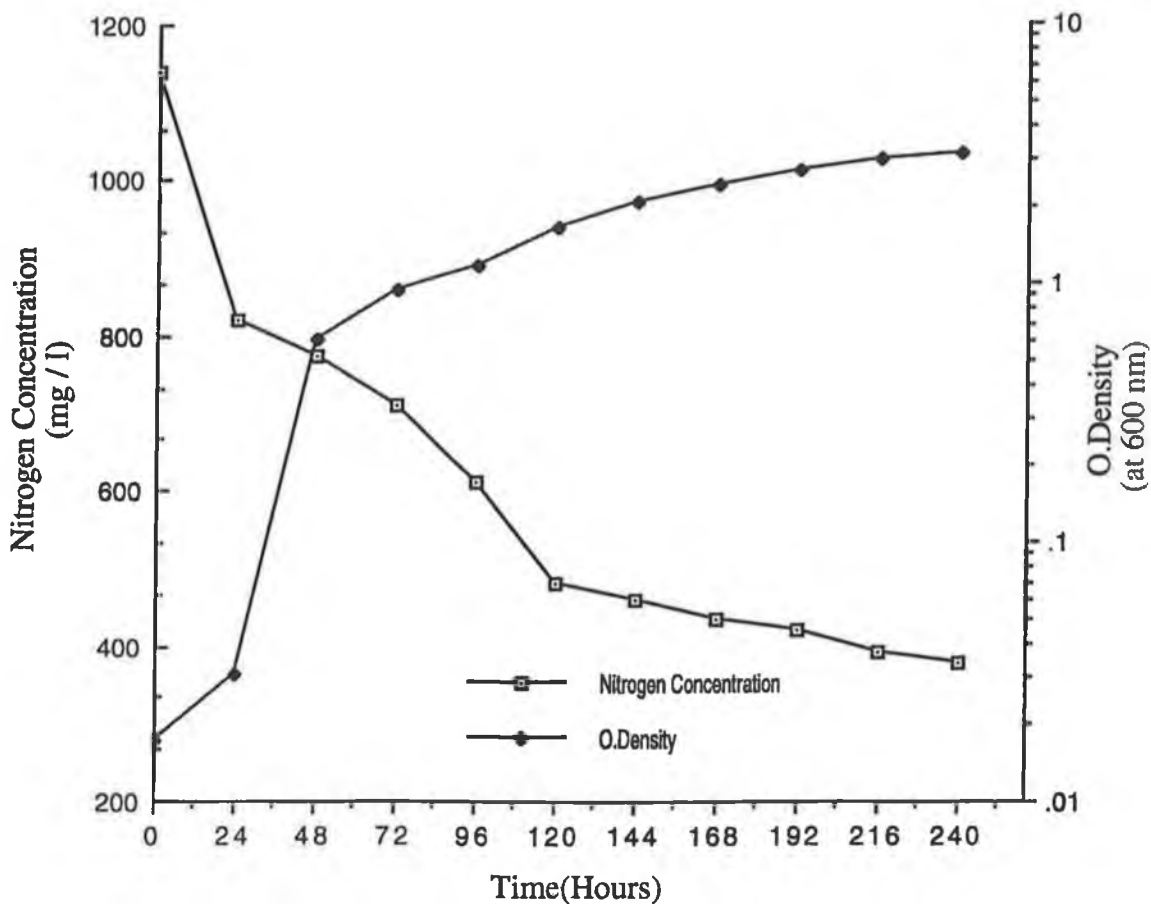
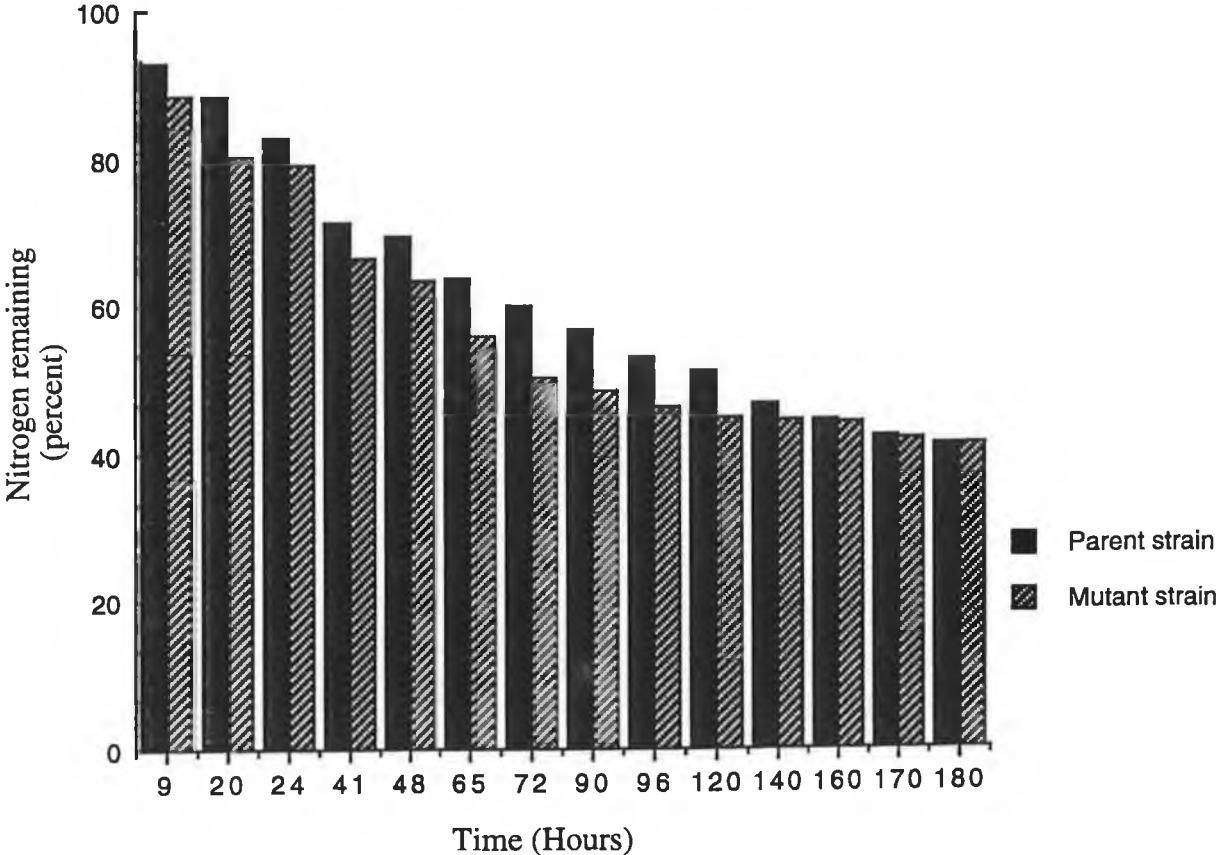

Figure 4.6.2.16 Percentage of the nitrogen source remaining in the growth medium during ten days growth of the parent strain (NCYC 874) and a mutant strain (NRRL-Y-18734) of *Phaffia rhodozyma*



A mutant strain of *Phaffia rhodozyma* (NRRL-Y-18734) was cultured in shake flask culture using a yeast malt broth and a mineral salts medium to culture the yeast.

Biomass production by the mutant strain grown in both media is shown in Figure 4.6.2.17, together with the range of error calculated at the 95% level.

Production of biomass by the mutant strain of *Phaffia rhodozyma* grown in a Yeast Malt Broth follows a different pattern to that observed for the parent strain of the yeast grown in the same medium. Biomass production by the mutant strain increases steadily for the first 48 hours of growth. Over the next 24 hours, there is a large increase in the yield of biomass, with an increase of 953 mg cell weight recorded during this time. This is the largest increase in biomass yield recorded in any one 24 hour period during this run. Biomass yields continue to increase up to 240 hours when the maximum yield of biomass was obtained. It should be noted that the statistical range of error calculated for the biomass yields obtained for runs 11 to 15 are quite low, with the error ranging from 1.4 to 7.8 mg. The standard error recorded for biomass yields for runs 1 to 5 was higher, with the error ranging from 5.45 to 26.7 mg cell weight. As the error was so low, the error bars cannot be seen on the graph.

In comparing the yields of biomass produced by the parent and mutant strain of *Phaffia rhodozyma* when grown in a batch system using a yeast malt broth, it can be observed that the yields of biomass produced by the mutant strain are 10 to 15 times greater than the yields produced by the parent strain during the same period of growth.

The production of biomass by the mutant strain of *Phaffia rhodozyma* cultured in a mineral salts medium follows the same pattern as that observed previously, when the growth medium used to culture the yeast was a yeast malt broth. Biomass production by the mutant strain cultured in the mineral salts medium increases over 240 hours, with a maximum yield of 3733.55 mg cell weight recorded at this time. The biggest increase in biomass yield occurs between 72 and 96 hours of growth with an increase of 766.66 mg cell weight recorded at this time. This is the biggest increase in biomass yield obtained in any one 24 hour period (Figure 4.6.2.17). Biomass yields produced by the mutant strain cultured in a mineral salts medium are higher than those produced by the

mutant strain cultivated in the yeast malt broth. The standard error calculated for the biomass yields recorded when the mutant was cultured in the mineral salts medium, lies in the range 2.72 to 9.46 mg which is statistically acceptable. The error was too low to register on the computer, and the error bars are therefore not shown on the graph.

The yields of biomass produced by the mutant strain cultivated in the mineral salts medium are 12 to 16 times greater than the yields of biomass produced by the parent strain cultured in the same medium.

Astaxanthin production by the mutant strain of *Phaffia rhodozyma* follows the same pattern observed with biomass production. Pigment production by the mutant strain cultured in the yeast malt broth and mineral salts medium is shown in Figure 4.6.2.18 together with the range of error of the mean calculated at the 95% confidence level.

When the mutant strain was grown in a Yeast Malt Broth the production of pigment from the cells increased over 240 hours with a maximum astaxanthin yield of 460.70 mg recorded after 240 hours of growth. The biggest increase in pigment yield occurred between 48 and 72 hours, when the yield of pigment produced by the cells increases by 108.79 mg per 25 mls culture fluid. This was the biggest increase in pigment yield recorded in any one 24 hour period. It was interesting to note that the biggest increase in pigment yield produced by the parent strain during any 24 hour period occurs between 96 and 120 hours of growth, 48 hours later than the biggest increase in yields produced by the mutant strain cultured in the same medium. It can also be observed from looking at pigment production by the mutant strain (Figure 4.6.2.18), that the range of error calculated for these results is low with the error ranging from 2.25 to 10.92 mg pigment, while the statistical range of error calculated for the pigment yields produced by the parent strain when cultured in the yeast malt broth is higher, with the error ranging from 4.81 to 21.30 mg pigment.

Pigment yields produced by the mutant strain cultured in a yeast malt broth are 3 to 4 times higher than the yields of pigment produced by the parent strain cultured in the same medium.

The production of pigment by the mutant strain of *Phaffia rhodozyma* cultured in a Yeast Malt Broth, follows a different pattern to that observed with the

parent strain grown in the same medium. The mutant strain continues to produce biomass and pigment over 240 hours. The parent strain of *Phaffia rhodozyma* produces increased biomass and pigment yields up to 120 hours, after which time the yields begin to decrease. This would seem to indicate that there is a difference in the utilisation of the carbon source by the parent and mutant strain of *Phaffia rhodozyma*, which would explain the fact that the mutant strain continues to produce biomass and pigment yields over 240 hours, while the parent strain continues to produce biomass and pigment yields for the first 120 hours of growth only.

The production of pigment by the mutant strain of *Phaffia rhodozyma* cultured in a mineral salts medium followed the same pattern observed previously for runs 11 to 15. The average yields of pigment produced by the mutant strain cultured in the mineral salts medium are shown in Figure 4.6.2.18, together with the range of error calculated at the 95% confidence level. Astaxanthin production by the mutant strain increased over 240 hours, with a maximum yield of 521.40 mg pigment recorded after 240 hours of growth. The levels of pigment produced by the mutant strain of *Phaffia rhodozyma* cultured in a mineral salts medium are higher than the yields produced by the mutant when cultivated in a yeast malt broth.

Growth of the mutant strain in a Yeast Malt Broth and a Mineral Salts Medium is shown graphically in Figure 4.6.2.19, together with the range of error of the mean, calculated at the 95% confidence level. Growth of the mutant strain cultured in the yeast malt broth begins immediately, and no lag phase of growth was observed. Cells enter the exponential phase of growth immediately, and this phase of growth lasted for 120 hours. Cells then enter the stationary phase, and growth remained constant at this time. The same pattern can be observed when the mutant was cultured in the Mineral Salts Medium. Cells enter the exponential growth phase immediately, and no lag phase was observed. Cells entered the stationary phase after 120 hours. The increase in growth during the first 120 hours of growth occurs in line with an increase in pigment and biomass production.

Figure 4.6.2.17 Yields of biomass produced by the mutant strain (NRRL-Y-18734) of *Phaffia rhodozyma* when grown in shake flask culture using a Yeast Malt Broth and a Mineral Salts Medium

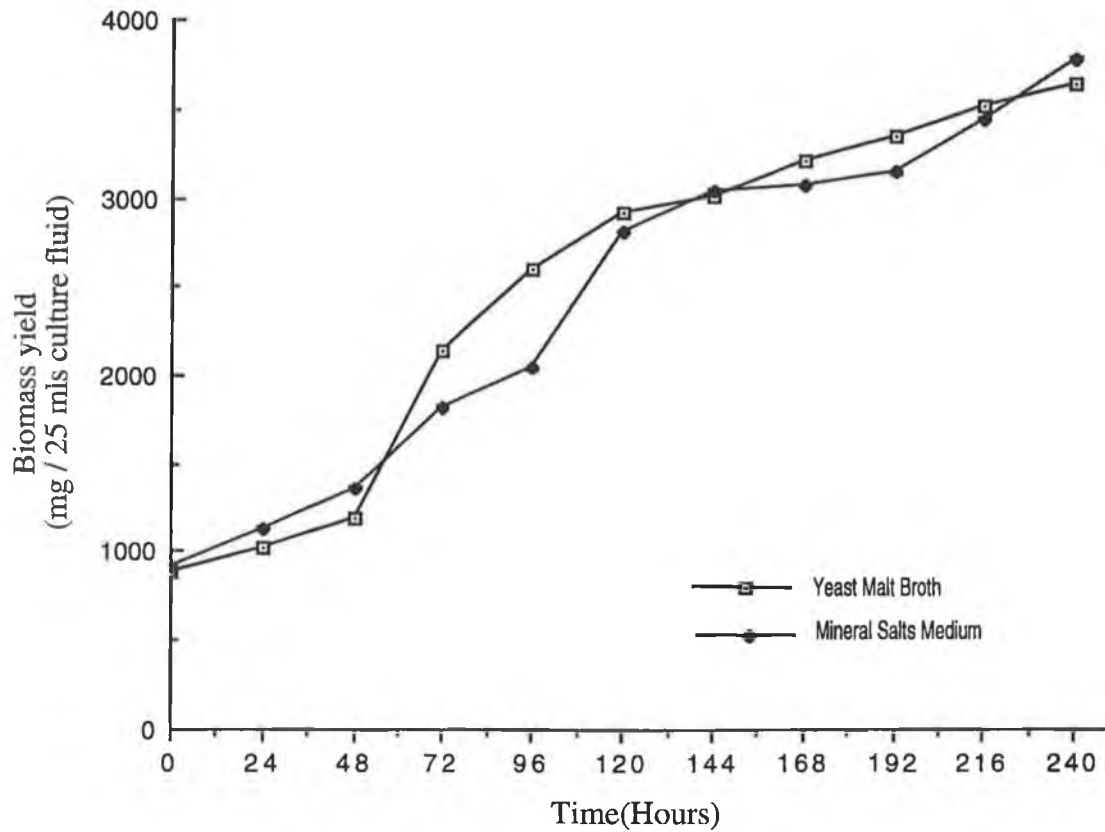

Figure 4.6.2.18 Pigment yields produced by the mutant strain (NRRL-Y-18734) of *Phaffia rhodozyma* when grown in shake flask culture using a Yeast Malt Broth and Mineral Salts Medium

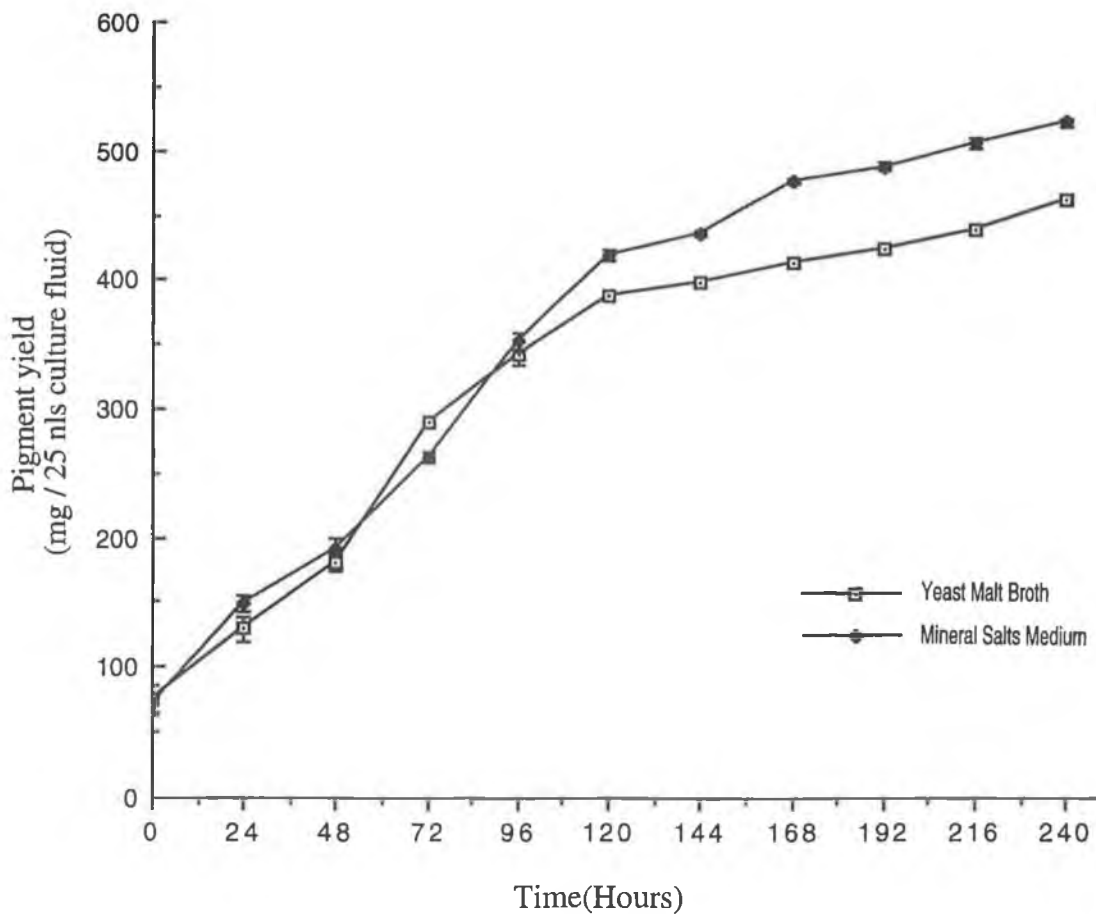
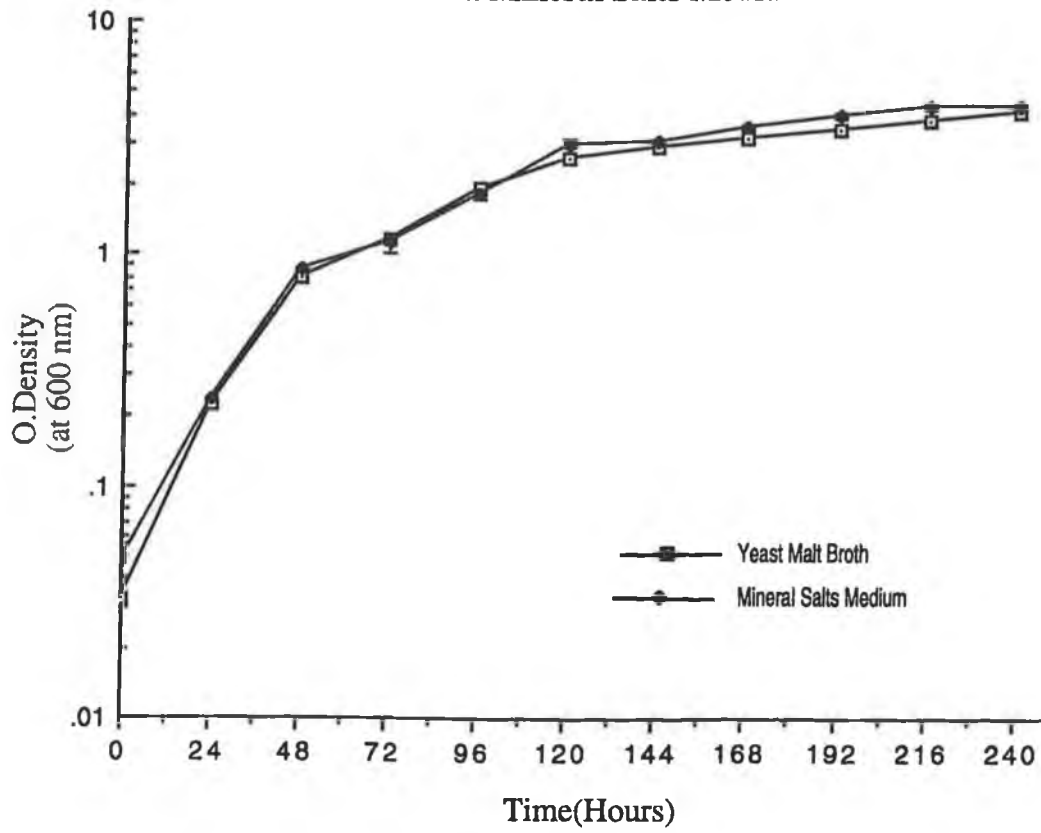

Figure 4.6.2.19 Growth of the mutant strain (NRRL-Y-18734) of *Phaffia rhodozyma* in shake flask culture using a Yeast Malt Broth and a Mineral Salts Medium



The mutant strain of *Phaffia rhodozyma* cultured in a yeast malt broth and mineral salts medium had a higher rate of growth than the parent strain cultured in the same media.

The utilisation of the carbon source by the mutant strain of *Phaffia rhodozyma* followed the same pattern as previously observed with the parent strain of the yeast. Glucose usage by the mutant strain of the yeast cultured in both growth media used is shown in Figure 4.6.2.20, together with the range of error calculated at the 95% confidence level.

Utilisation of the carbon source by the mutant strain of *Phaffia rhodozyma* does not occur as rapidly as previously observed with the parent strain of the yeast. The range of error of the mean was too low to register on the computer and therefore cannot be seen on the graph. As observed with the parent strain, glucose usage during the first 72 hours of growth is at a maximum. As the yields of biomass (Figure 4.6.2.21) and pigment (Figure 4.6.2.22) produced by the mutant strain increased, there was rapid consumption of the carbon source. The parent strain utilised the carbon source very rapidly during the first 96 hours of growth with 6.82% of the carbon source remaining after this time. This could explain the subsequent decrease in biomass and pigment yields recorded after 120 hours of growth. The same pattern can be observed with cell growth and glucose usage (Figure 4.6.2.23).

Looking at glucose consumption by the mutant strain in terms of the percentage glucose remaining in the growth medium (Figure 4.6.2.24), the pattern of glucose usage can be observed. After 72 hours growth in a Yeast Malt Broth just 11.54% of the carbon source remains in the medium, while after 72 hours of growth in a Mineral Salts Medium 5.94% of the carbon source remains.

Consumption of the carbon source by the mutant strain during the first 48 hours of growth is slower than the consumption of glucose by the parent strain during the same period. When the mutant strain was cultured in the mineral salts medium, 31.78% of the carbon source remained after 48 hours. When the parent strain was cultured in the yeast malt broth and mineral salts medium, 9.8% to 10.03% of the carbon source remained after this time. The mutant strain consumed the carbon source more slowly than the parent strain, during the first 96 hours. However, after 120 hours only 4.06% to 5.51% of the carbon source remains in the medium.

Figure 4.6.2.20 Glucose consumption by the mutant strain (NRRL-Y-18734) of *Phaffia rhodozyma* grown in shake flask culture using a Yeast Malt Broth and a Mineral Salts Medium

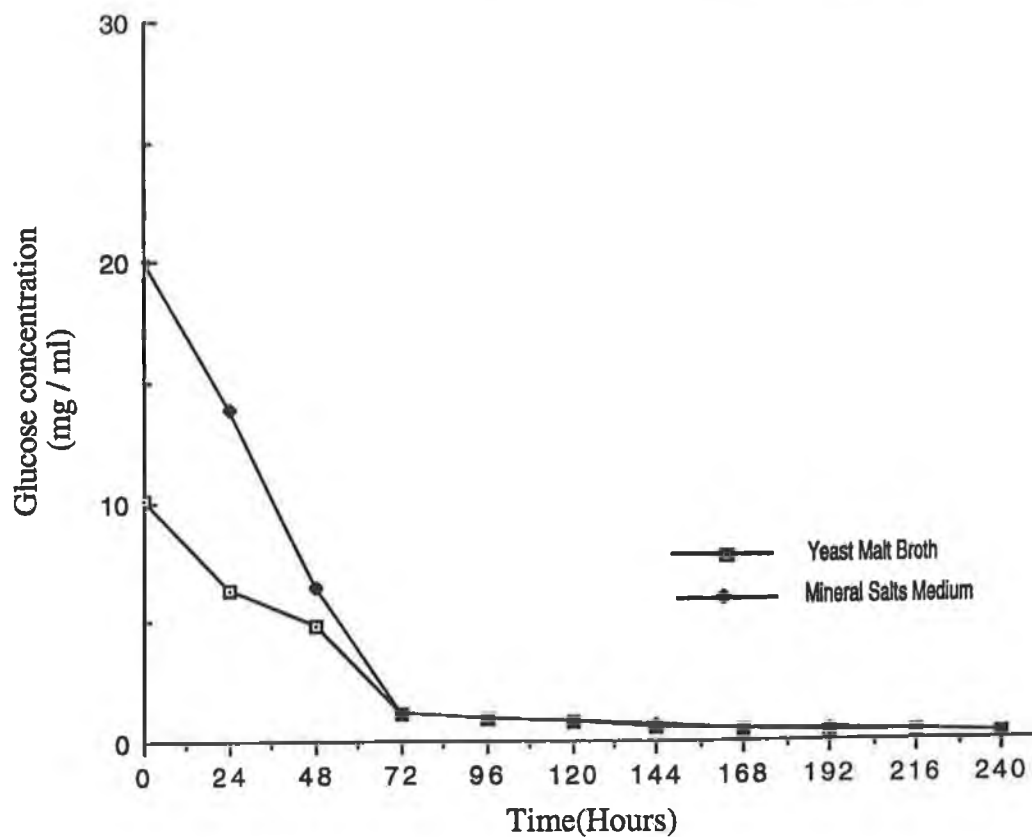

Figure 4.6.2.21 Biomass production and substrate consumption by a mutant strain (NRRL-Y-18734) of *Phaffia rhodozyma* grown in shake flask culture using a Yeast Malt Broth

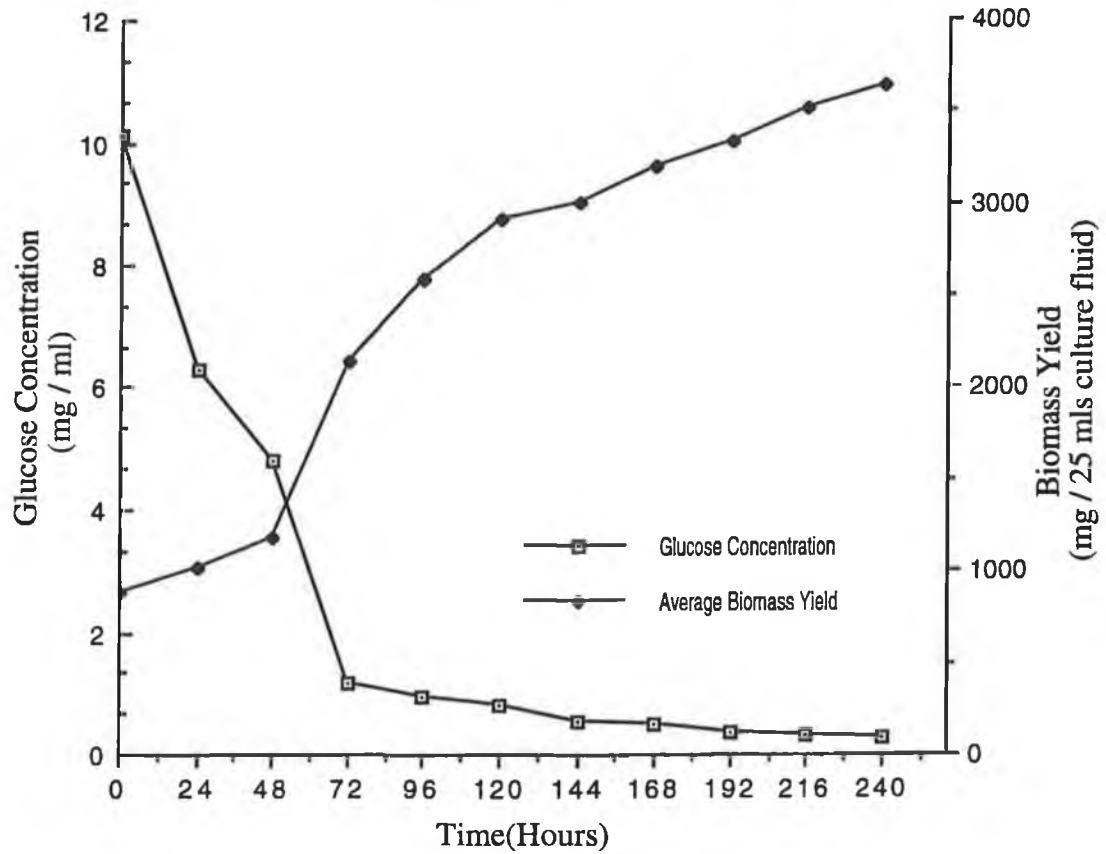

Figure 4.6.2.22 Pigment production and substrate consumption by a mutant strain (NRRL-Y-18734) of *Phaffia rhodozyma* grown in shake flask culture using a Yeast Malt Broth

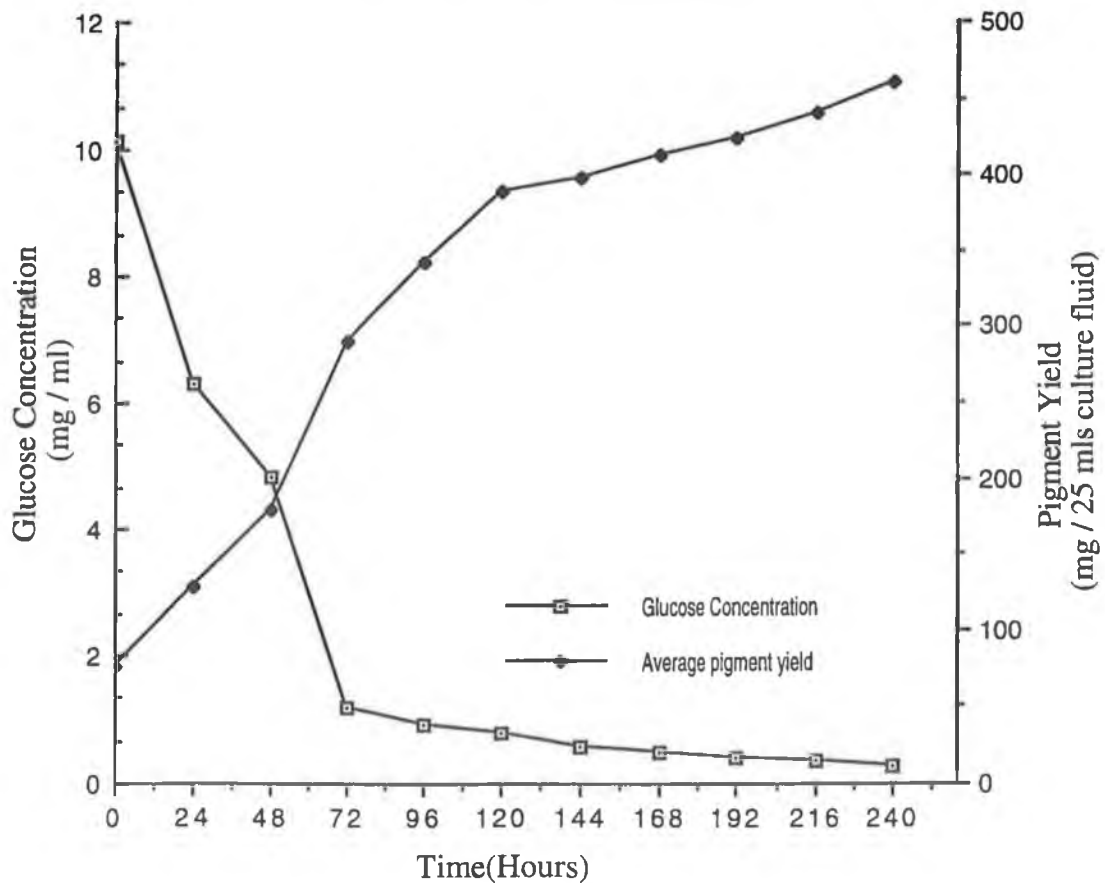

Figure 4.6.2.23 Growth and substrate consumption by a mutant strain (NRRL-Y-18734) of *Phaffia rhodozyma* grown in shake flask culture using a Mineral Salts Medium

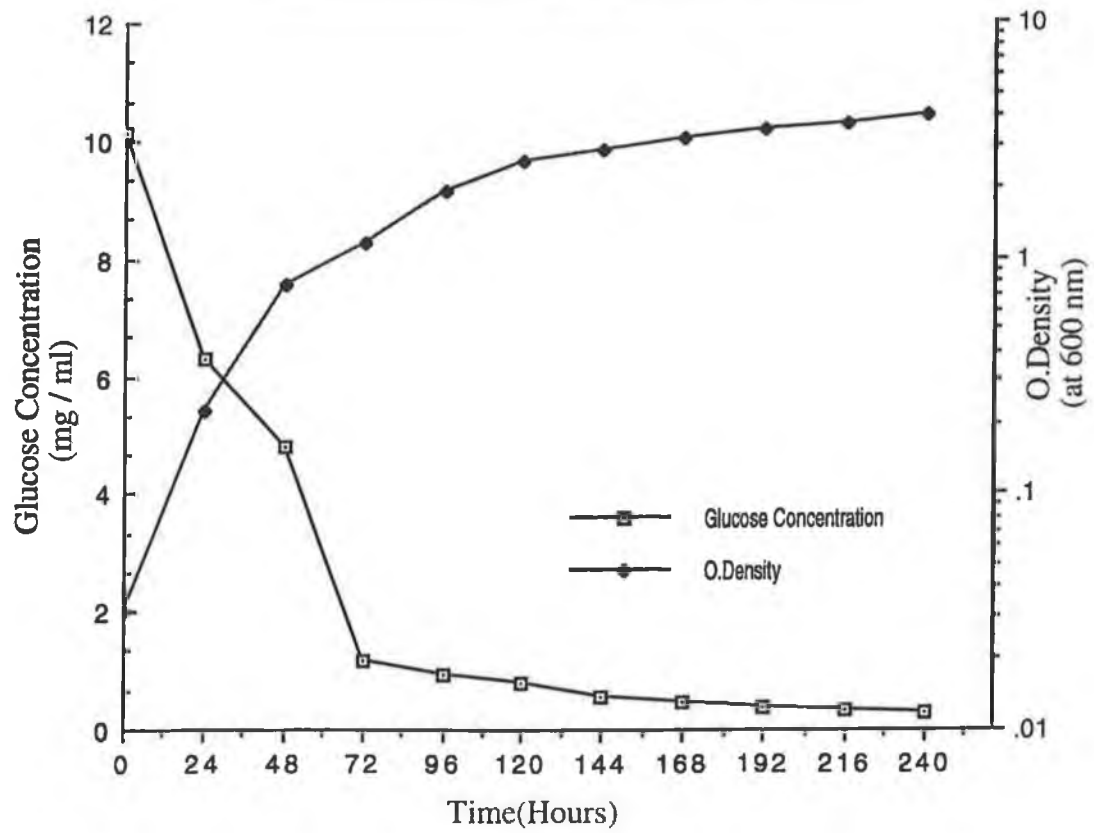
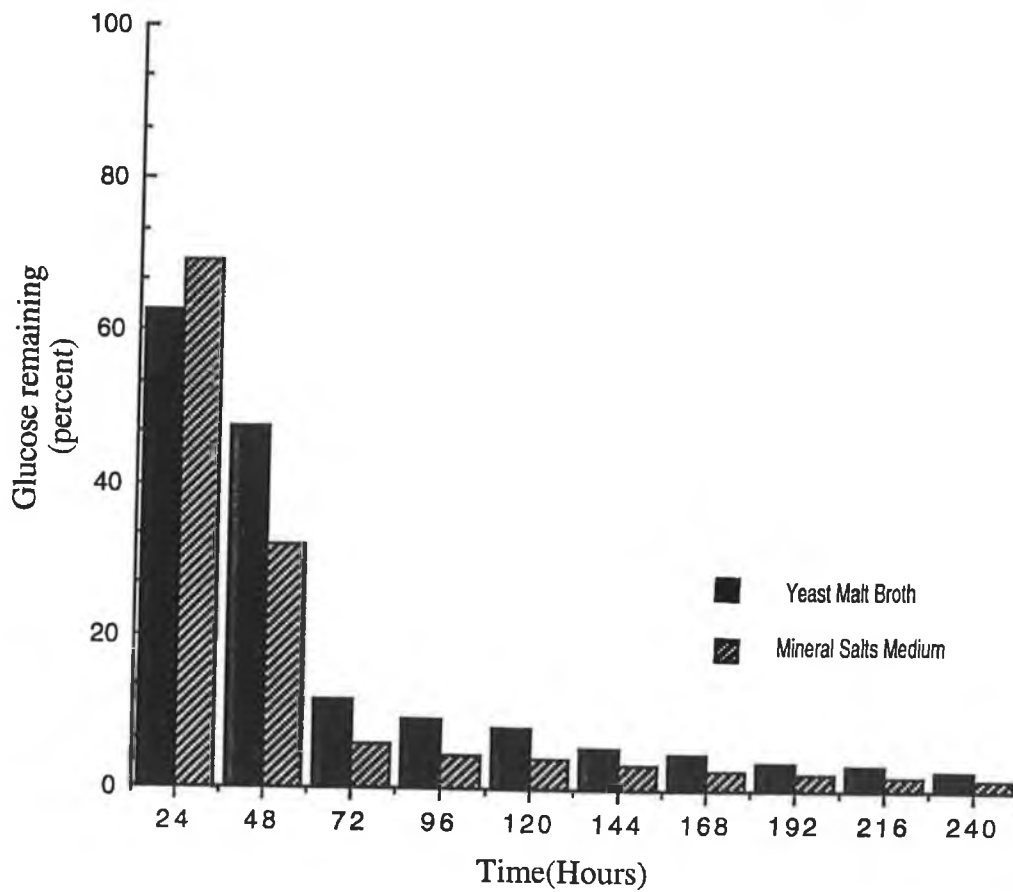

Figure 4.6.2.24 Percentage of the carbon source remaining in the growth medium during ten days growth of the mutant strain (NRRL-Y-18734) of *Phaffia rhodozyma* in shake flask culture



This is in line with the consumption of the carbon source by the parent strain, where just 4.3% to 6.8% remains in the medium after 120 hours. Glucose consumption by the mutant strain is linked to biomass production and growth. As biomass yields (Figure 4.6.2.25) and pigment yields (Figure 4.6.2.26) increase, so does glucose consumption. Even when the carbon source is almost depleted, the mutant strain continues to produce biomass and pigment. The same pattern can be observed for cell growth and glucose consumption (Figure 4.6.2.27).

Consumption of the nitrogen source by the mutant strain of *Phaffia rhodozyma* was also investigated. Nitrogen usage by the mutant strain cultured in the mineral salts medium, is shown in Figure 4.6.2.12 .

It can be observed from these results that there is a slightly different pattern of nitrogen usage by the mutant strain of *Phaffia rhodozyma* than was observed previously for the parent strain. There is less usage of the nitrogen source by the mutant strain of the yeast during the first 24 hours of growth. However, after this time, the mutant strain of the yeast consumes more of the nitrogen source than the parent strain. Over 240 hours of culturing consumption of nitrogen remains steady.

If the results for nitrogen consumption are presented as the percentage of the nitrogen source remaining in the growth medium over time (Figure 4.6.2.16), usage of the nitrogen source by the mutant strain can be clearly observed.

Nitrogen consumption by the mutant strain follows a different pattern to that observed with the parent strain. The mutant strain consumes 12.92% of the available nitrogen during the first 24 hours of growth. During the same period the parent strain consumes 27.98%, twice as much.

After 240 hours of growth the mutant strain has consumed 82.50% of the nitrogen, while the parent strain has consumed 66.82% after this time. Twice as much of the nitrogen source is available to the parent strain after 240 hours than is available to the mutant strain. This indicates that the mutant strain of *Phaffia rhodozyma* is more effective at consuming the nitrogen source than the parent strain of the yeast.

Figure 4.6.2.25 Biomass production and substrate consumption by a mutant strain (NRRL-Y-18734) of *Phaffia rhodozyma* grown in shake flask culture using a Mineral Salts Medium

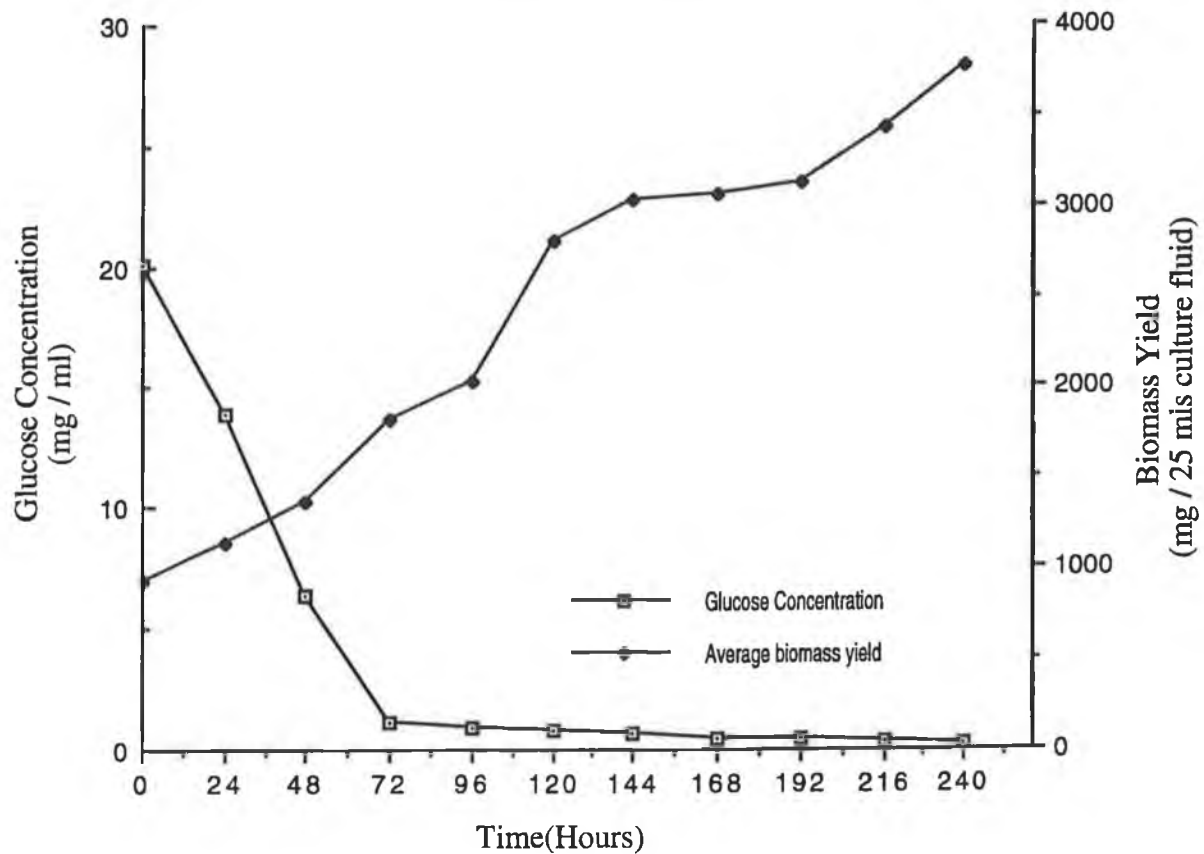

Figure 4.6.2.26 Astaxanthin production and substrate consumption by a mutant strain (NRRL-Y-18734) of *Phaffia rhodozyma* grown in shake flask culture using a Mineral Salts Medium

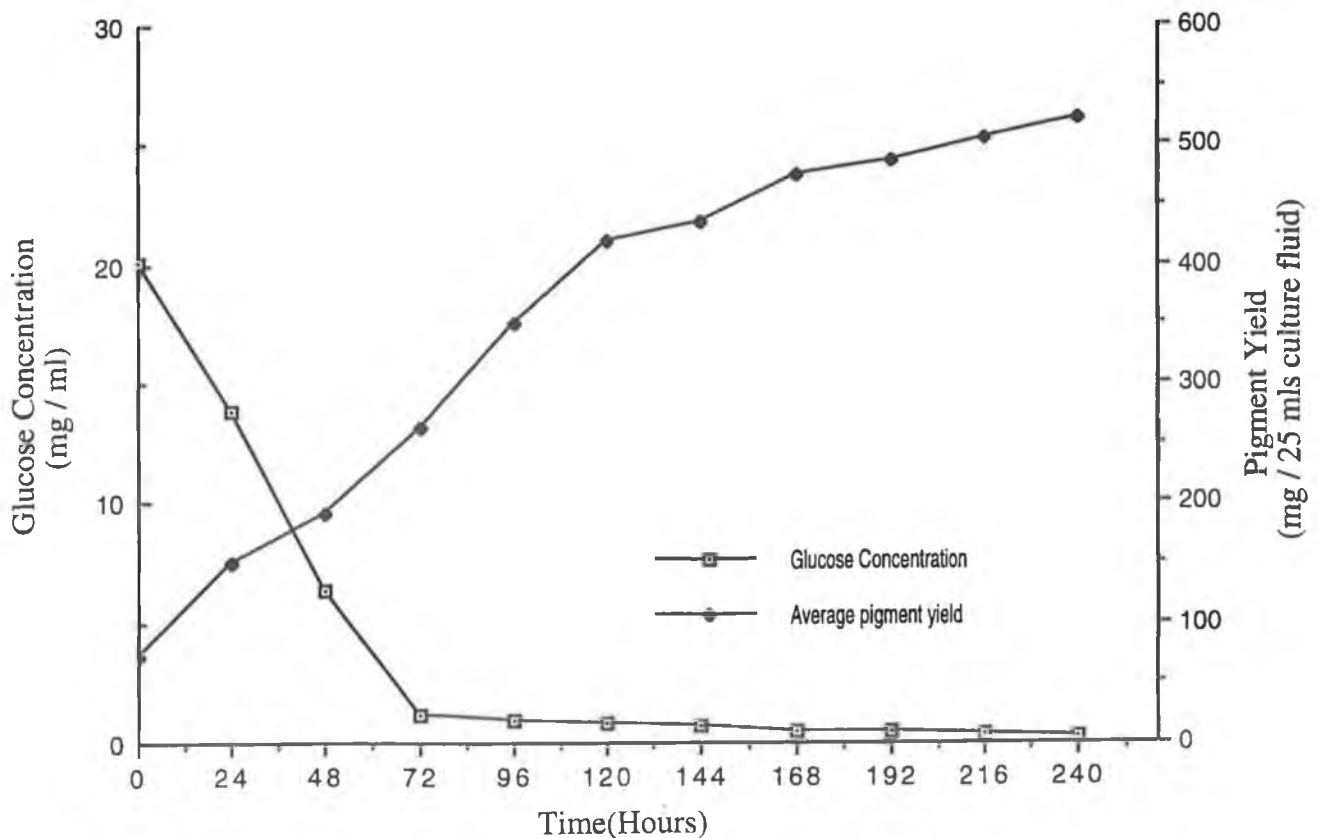
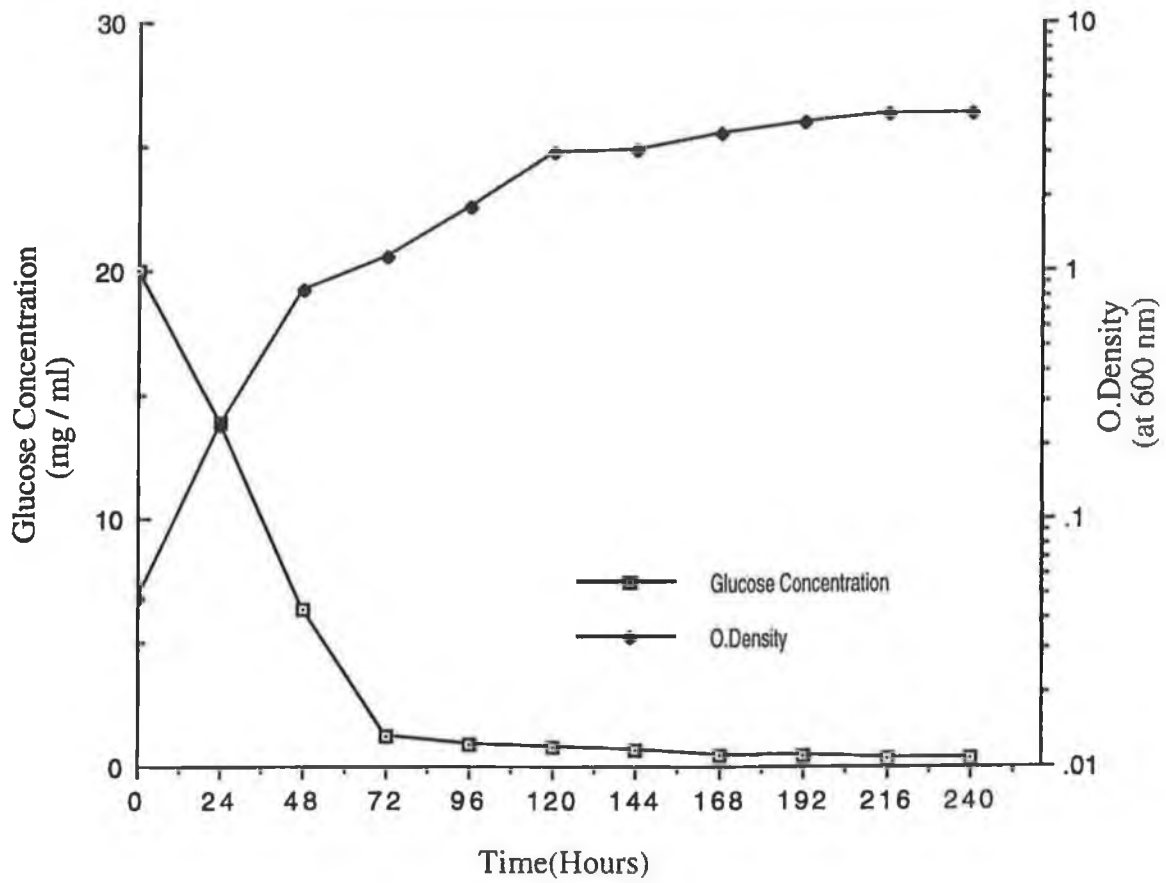

Figure 4.6.2.27 Growth and glucose consumption by a mutant strain (NRRL-Y-18734) of *Phaffia rhodozyma* grown in shake flask culture using a Mineral Salts Medium



As biomass and astaxanthin production by the mutant strain increases, consumption of the nitrogen source also increases, indicating that consumption of the available nitrogen is linked to biomass and pigment production by the cells (Figures 4.6.2.28 and 4.6.2.29). As observed previously, as the yields of pigment and biomass produced by the parent strain falls after 120 hours, so too does the consumption of nitrogen (Figure 4.6.2.13 and Figure 4.6.2.14), with the percentage remaining in the growth medium falling by just 1.3% to 2.42% every 24 hours after this time. The same pattern can be observed for cell growth and nitrogen consumption by the mutant strain (Figure 4.6.2.30).

Consumption of nitrogen by the mutant strain follows a different pattern to that observed for glucose. While 5.91% of the carbon source remains in the growth medium after 72 hours, 52.42 of the nitrogen source remains after this time, approximately twice as much.

Figure 4.6.2.28 Biomass production and nitrogen consumption by a mutant strain (NRRL-Y-18734) of *Phaffia rhodozyma* grown in shake flask culture using a Mineral Salts Medium

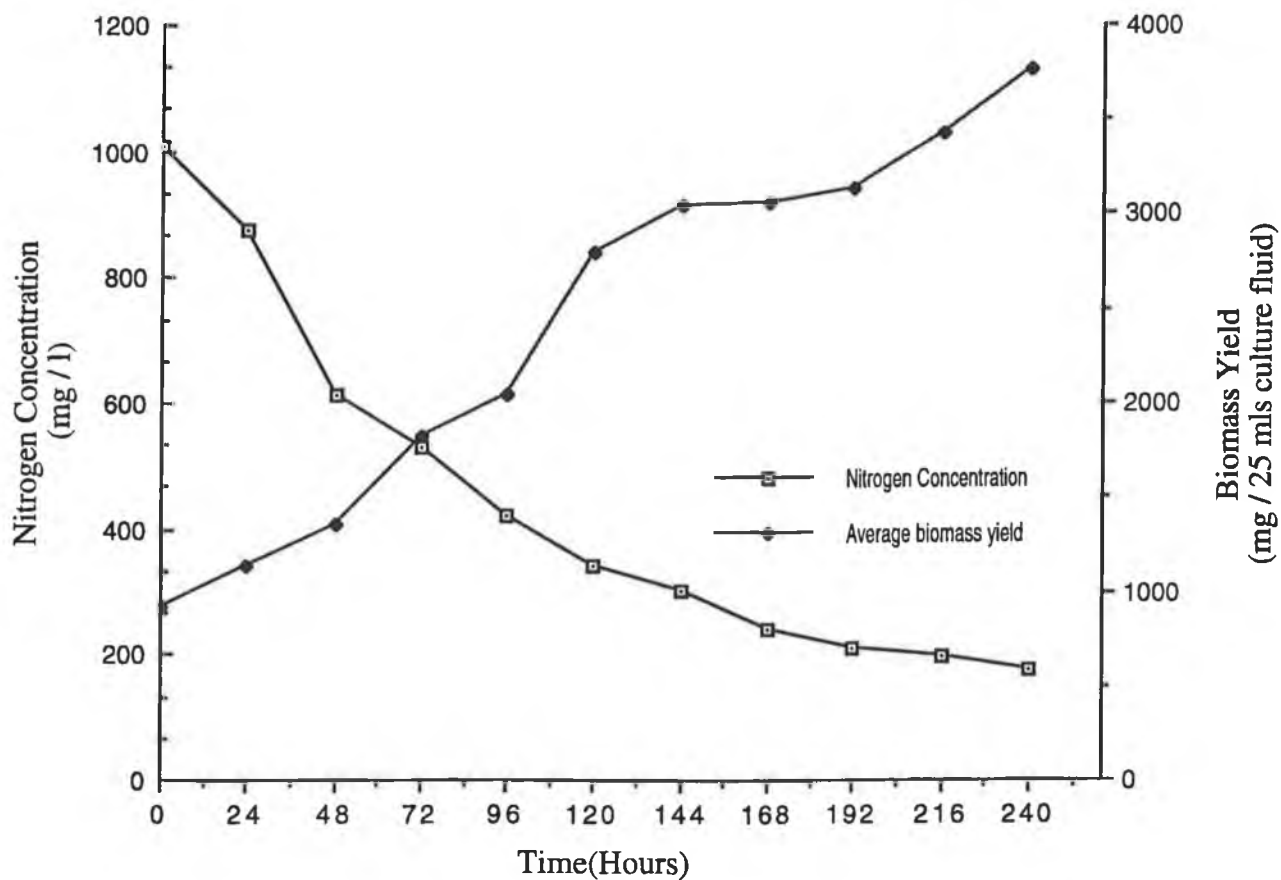

Figure 4.6.2.29 Astaxanthin production and nitrogen consumption by a mutant strain (NRRL-Y-18734) of *Phaffia rhodozyma* grown in shake flask culture using a Mineral Salts Medium

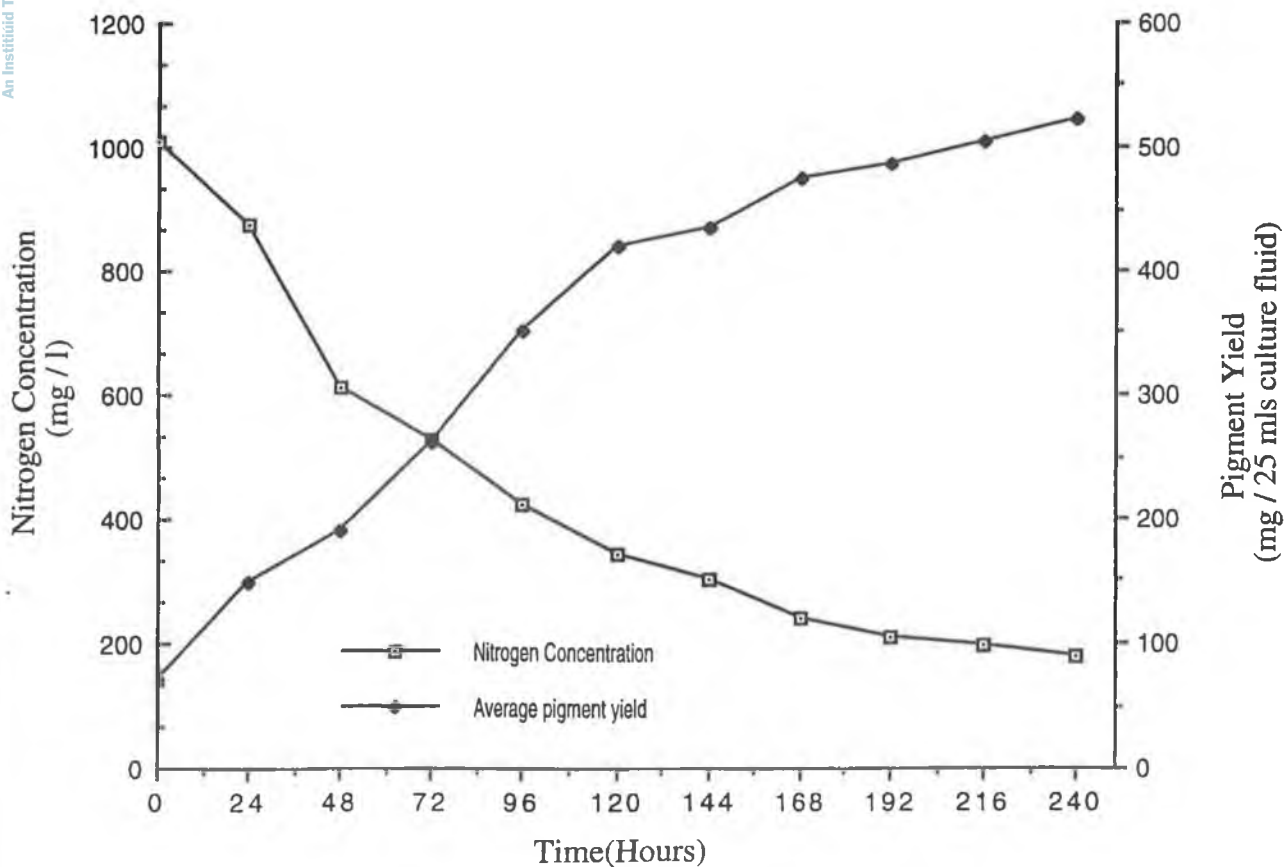
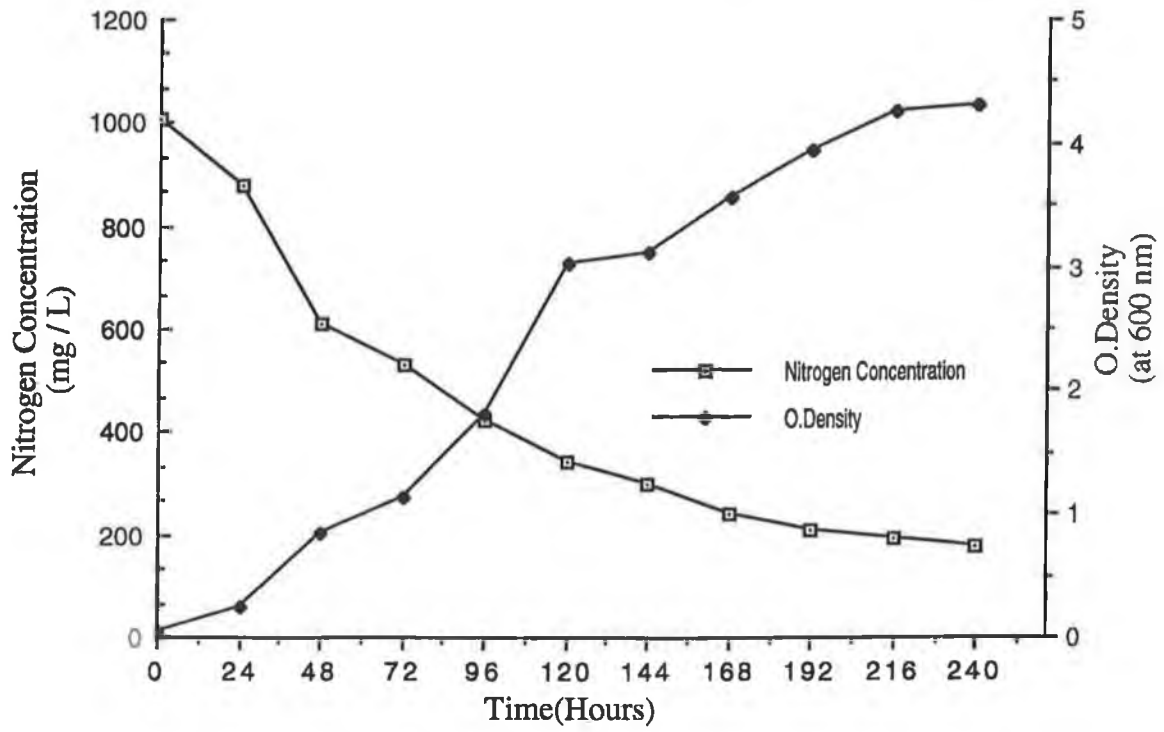

Figure 4.6.2.30 Growth and nitrogen consumption by a mutant strain (NRRL-Y-18734) of *Phaffia rhodozyma* grown in shake flask culture using a Mineral Salts Medium



Statistical analysis was carried out on the data generated in this section of research, as described fully in Chapter Three, to determine the extent of correlation, if any, between;

- (i) Biomass and astaxanthin production,
- (ii) Astaxanthin production and growth (as measured by optical density),
- (iii) Biomass production and cell growth,
- (iv) Glucose consumption and pigment production,
- (v) Glucose consumption and biomass production,
- (vi) Glucose consumption and growth (as measured by optical density).
- (vii) Nitrogen consumption and pigment production,
- (viii) Nitrogen consumption and biomass production,
- (ix) Nitrogen consumption and growth, and
- (x) Nitrogen usage and glucose consumption.

Table 4.6.2.1 Coefficients of correlation calculated for biomass and astaxanthin production by the parent strain and a mutant strain of *Phaffia rhodozyma*

Cultivation	Coefficient of Correlation (r)	T - Statistic (t)	Accept/reject null hypothesis (r = 0)
Parent strain (NCYC 874) grown in a yeast malt broth	0.900579	5.86	reject
Parent strain (NCYC 874) grown in a mineral salts medium	0.927698	7.04	reject
Mutant strain (NRRL-Y-18734) grown in a yeast malt broth	0.991921	22.12	reject
Mutant strain (NRRL-Y-18734) grown in a mineral salts medium	0.983482	15.37	reject

* YMB = Abbreviation for Yeast Malt Broth

* MSM = Abbreviation for Mineral Salts Medium

The t-value obtained from the t-table for sample size 10, minus 2 (n-2), at a 95% confidence level, was 1.82. Where the t-statistic exceeds this value, the null hypothesis of no correlation is rejected, therefore the correlation coefficient obtained is accepted as being statistically significant at the 95% confidence level. Where the t-statistic does not exceed 1.86, then the null hypothesis is accepted, and the correlation coefficients are not accepted as being statistically significant.

The results shown in Table 4.6.2.1 indicate that strong positive correlation exists between pigment and biomass production by *Phaffia rhodozyma*, and that

there is therefore a strong linear relationship between these two parameters. All of the correlation values obtained are statistically significant at the 95% confidence level, therefore, the null hypothesis is rejected. Positive correlation implies that large values of biomass (x) are associated with large values of pigment (y), and that small values of x are associated with small values of y. Statistical analysis of the results for biomass and pigment production obtained for the parent and mutant strain of the yeast show a significant positive correlation between pigment and biomass production. As observed previously for biomass and pigment production by the parent strain, where a decrease in pigment yields was recorded, so too was a decrease in biomass yields. This finding is borne out by the statistical analysis, which proves that positive correlation exists between these two parameters. Positive correlation exists for biomass and pigment production for the parent strain, but it must be noted that the correlation coefficients obtained for the mutant strain are statistically more significant.

Table 4.6.2.2 Correlation coefficients for astaxanthin production and growth by the parent and mutant strain of *Phaffia rhodozyma*

Run Number	Coefficient of Correlation (r)	T - Statistic (t)	Accept/reject null hypothesis (r = 0)
Strain NCYC 874 grown in a YMB	0.506458	1.66*	accept
Strain NCYC 874 grown in a MSM	0.715204	2.89	reject
Strain NRRL-Y-18734 grown in a YMB	0.968787	11.05	reject
Strain NRRL-Y-18734 grown in a MSM	0.983039	15.16	reject

* Result not statistically acceptable at the 95% confidence level

The results shown in Table 4.6.2.2 indicate that one of the correlation coefficients is not statistically significant. Astaxanthin production by the parent strain decreased after 120 hours of growth, yet the optical density measurements recorded continued to increase after this time. It would be

expected that a decrease in pigment production would be linked to a fall in cell numbers, but this does not occur, and this explains why the correlation coefficient for runs 1 to 5 was not significant.

All of the other correlation coefficients are statistically significant at the 95% confidence level. This indicates that a strong positive correlation exists between cell growth and pigment production. The results are more statistically significant for the mutant strain of the yeast, and this is expected, as the yields of pigment produced by the cells increases over 240 hours, as does the cell numbers.

Table 4.6.2.3 Correlation coefficients for biomass production and growth for the parent and mutant strain of *Phaffia rhodozyma*

Run Number	Coefficient of Correlation (r)	T - Statistic (t)	Accept/reject null hypothesis (r = 0)
Strain NCYC 874 grown in a YMB	0.483344	1.56*	accept
Strain NCYC 874 grown in a MSM	0.489531	1.59*	accept
Strain NRRL-Y-18734 grown in a MSM	0.980947	14.28	reject
Strain NRRL-Y-18734 grown in a MSM	0.992295	22.65	reject

* Result not statistically acceptable at the 95% confidence level

Again, the results shown in Table 4.6.2.3 indicate a strong positive correlation exists between biomass production and growth. The correlation coefficients obtained for the parent strain cultured in both of the growth media are not statistically significant at the 95% confidence level. This is expected, as the yields of biomass produced by the parent strain decrease after 120 hours of growth, yet the optical density measurements recorded after this time increase. As the production of biomass decreases, a decrease in cell numbers would also be expected. The correlation coefficients obtained for biomass production and growth for the mutant strain show a very strong positive correlation existing

between growth and biomass production. The coefficients are both highly significant. This is expected, since the production of biomass by the mutant strain increases over 240 hours, as do the optical density measurements recorded.

Table 4.6.2.4 Correlation coefficients for glucose consumption and pigment production for the parent and mutant strain of *Phaffia rhodozyma*

Run Number	Coefficient of Correlation (r)	T - Statistic (t)	Accept/reject null hypothesis (r = 0)
Strain NCYC 874 grown in a YMB	- 0.55590	- 1.89	reject
Strain NCYC 874 grown in a MSM	- 0.88449	- 1.56	reject
Strain NRRL-Y-18734 grown in a YMB	- 0.94297	- 4.43	reject
Strain NRRL-Y-18734 grown in a MSM	- 0.86750	- 5.03	reject

The results shown above indicate that a strong, statistically significant negative correlation exists between glucose consumption and pigment production by *Phaffia rhodozyma*. Negative correlation implies that large values of y(astaxanthin) tend to go with small values of x(glucose). Strong negative correlation exists between pigment production and glucose usage for both the parent and mutant strain of the yeast. The correlation values obtained are all statistically significant at the 95% confidence level. As the glucose is being consumed by the parent and mutant strain of the yeast, the yields of pigment produced increases. Negative correlation reflects this. Even though the yields of pigment produced by the parent strain decreases after 120 hours, glucose continues to be consumed. However, since over 95% of the carbon source has been used during the first 120 hours of growth, as pigment yields are increasing, the negative correlation finding holds true.

Table 4.6.2.5 Correlation coefficients for glucose consumption and biomass production for the parent and mutant strain of *Phaffia rhodozyma*

Run Number	Coefficient of Correlation (r)	T - Statistic (t)	Accept/reject null hypothesis (r = 0)
Strain NCYC 874 grown in a YMB	- 0.64724	- 2.40	reject
Strain NCYC 874 grown in a MSM	- 0.75943	- 3.29	reject
Strain NRRL-Y-18734 grown in a YMB	- 0.89867	- 5.54	reject
Strain NRRL-Y-18734 grown in a MSM	- 0.79826	- 3.75	reject

The results shown above indicate a strong negative correlation between the consumption of the carbon source and biomass production. As described previously with glucose consumption and pigment production, the same pattern of negative correlation can be observed here. All of the correlation values are significant at the 95% confidence level. As the glucose is consumed by the parent and mutant strain, biomass production increases. Even though the yields of biomass produced by the parent strain decreases after 120 hours, over 95% of the carbon source has been consumed during this time, and this supports the negative correlation finding obtained here.

The results shown in Table 4.6.2.6 indicate that negative correlation exists between consumption of the carbon source and growth of the yeast (as measured by optical density). As glucose is consumed by the parent and mutant strains, cell numbers increase. The results are all statistically significant at the 95% confidence level. It must be noted that the negative correlation results are more statistically significant for the mutant strain of the yeast.

Table 4.6.2.6 Correlation coefficients for glucose consumption and growth of the parent and mutant strain of *Phaffia rhodozyma*

Run Number	Coefficient of Correlation (r)	T - Statistic (t)	Accept/reject null hypothesis (r = 0)
Strain NCYC 874 grown in a YMB	- 0.77184	- 3.43	reject
Strain NCYC 874 grown in a MSM	- 0.70307	- 2.79	reject
Strain NRRL-Y-18734 grown in a YMB	- 0.84303	- 4.43	reject
Strain NRRL-Y-18734 grown in a MSM	- 0.78488	- 3.58	reject

Table 4.6.2.7 Correlation coefficients for nitrogen consumption and astaxanthin production for the parent and mutant strain of *Phaffia rhodozyma*

Run Number	Coefficient of Correlation (r)	T - Statistic (t)	Accept/reject null hypothesis (r = 0)
Strain NCYC 874 grown in a MSM	- 0.87862	- 5.20	reject
Strain NRRL-Y-18734 grown in a MSM	- 0.98010	- 13.96	reject

There is a strong negative correlation between pigment production and consumption of the nitrogen source, for both the parent and mutant strain of the yeast. As observed previously with the correlation between glucose consumption and pigment production, as the yields of pigment produced by the cells increases, the nitrogen source is depleted. There is a decrease in pigment yields by the parent strain after 120 hours, but the nitrogen source continues to be consumed after this time. Stronger negative correlation exists between astaxanthin production and nitrogen usage, for the mutant strain. This

strengthens the previous claim made that the mutant strain is more efficient than the parent strain at utilising the available nitrogen.

Table 4.6.2.8 Correlation coefficients calculated for nitrogen consumption and biomass production for the parent and mutant strain of *Phaffia rhodozyma*

Run Number	Coefficient of Correlation (r)	T - Statistic (t)	Accept/reject null hypothesis (r = 0)
Strain NCYC 874 grown in a MSM	- 0.68487	- 2.66	reject
Strain NRRL-Y-18734 grown in a MSM	- 0.94841	- 8.46	reject

Strong negative correlation exists between consumption of nitrogen and biomass production, and this is also seen to be the case for usage of nitrogen and pigment production. Both correlation values obtained are statistically significant at the 95% confidence levels. Even though biomass yields by the parent strain decreased after 120 hours, consumption of the nitrogen source continues after this time. The negative correlation value obtained for the mutant strain is higher than that obtained for the parent strain, and shows a stronger negative correlation existing between biomass production and nitrogen consumption for the mutant strain. This result indicates that the mutant strain of the yeast is more efficient at utilising the nitrogen source than the parent strain, and this may be reflected in the increased biomass and pigment yields obtained over 240 hours.

The results shown in Table 4.6.2.9 indicate that strong negative correlation exists between growth of the parent and mutant strain of *Phaffia rhodozyma* (as measured by optical density), and consumption of the carbon source. As the nitrogen source is consumed, cell numbers increase. As observed previously for correlation between consumption of the nitrogen source and biomass and pigment production, stronger negative correlation for the mutant strain for nitrogen consumption and growth. Both results are statistically significant at the 95% confidence level.

Table 4.6.2.9 Correlation coefficients calculated for consumption of nitrogen and growth of the parent and mutant strain of *Phaffia rhodozyma*

Run Number	Coefficient of Correlation (r)	T - Statistic (t)	Accept/reject null hypothesis (r = 0)
Strain NCYC 874 grown in a MSM	- 0.91801	- 6.55	reject
Strain NRRL-Y-18734 grown in a MSM	- 0.94845	- 8.46	reject

Table 4.6.2.10 Correlation coefficients calculated for nitrogen consumption and glucose consumption for the parent and mutant strain of *Phaffia rhodozyma*

Run Number	Coefficient of Correlation (r)	T - Statistic (t)	Accept/reject null hypothesis (r = 0)
Strain NCYC 874 grown in a MSM	0.864331	4.86	reject
Strain NRRL-Y-18734 grown in a MSM	0.936012	7.52	reject

Positive correlation is observed to exist between consumption of the nitrogen source, and glucose consumption by the parent and mutant strain of *Phaffia rhodozyma*. Positive correlation implies that small values of x are associated with small values of y. As biomass and pigment are produced by the yeast, the carbon and nitrogen sources are depleted. It should be noted that although both results are statistically significant at the 95% confidence level, the correlation result obtained for the mutant strain is statistically more significant. These results indicate that there is a close association between the consumption of the carbon and nitrogen sources, and the production of pigment and biomass by the parent and mutant strain of *Phaffia rhodozyma*.

Comparing the correlation coefficients obtained for consumption of glucose and nitrogen with biomass and pigment production by the yeast, several

observations may be made. A stronger negative correlation exists between the consumption of nitrogen and biomass production by the parent strain of the yeast, than exists between consumption of the carbon source and production of biomass. This indicates that production of biomass by the parent strain is more closely linked to the consumption of nitrogen, than to consumption of glucose. The opposite is observed to be the case regarding the mutant strain, with production of biomass more strongly linked to consumption of glucose, than consumption of nitrogen.

Strong negative correlation exists between the consumption of the carbon source and growth, for both the parent strain of the yeast. This indicates that the growth of the yeast is more strongly linked to glucose consumption, than usage of the nitrogen source.

As regards the negative correlation observed between pigment production and consumption of nitrogen, the correlation results obtained indicate that pigment production by the mutant strain is more closely linked to nitrogen consumption. The opposite is seen to be the case for the parent strain, with pigment production more closely related to glucose consumption. This indicates that the mutant strain is more efficient at utilising the available nitrogen to produce pigment than the parent strain. This could be due to the mutagenesis undergone by the mutant strain.

4.7 Effect of supplementation of glucose on growth and pigment production by *Phaffia rhodozyma* grown in a batch culture

4.7.1 Introduction

As a result of research carried out into culture conditions for *Phaffia rhodozyma*, it has been postulated that astaxanthin is formed as a secondary metabolite during the growth of *Phaffia rhodozyma* (Prevatt *et al.* 1991). Initially, the nutrient sources are utilised solely for growth with surplus carbon then used to build the basic forty carbon chain of astaxanthin. Carbon is present in finite levels in the growth medium, and can be used less than efficiently in growth.

The results obtained in the previous section of this work have shown that consumption of the carbon source by the parent and mutant strain of *Phaffia rhodozyma* is rapid. The parent strain consumed over 95% of the carbon source during the first 120 hours of growth, as did the mutant strain of the yeast. Biomass and pigment yields produced by the mutant strain after this time increased, while the yields of biomass and astaxanthin produced by the parent strain decreased, when less than 5% of the carbon source remained in the medium.

The addition of fresh substrate to the growth medium after 120 hours, when the stationary phase has been reached by the cells, was carried out to determine if an increase in biomass or pigment yields produced by the parent strain after 120 hours would increase as a result.

4.7.2 Analysis of Results

Biomass production by *Phaffia rhodozyma* during the control cultivations, using glucose concentrations of 1% and 1.5% is shown in Figure 4.7.2.1, together with the range of error for the mean calculated at the 95% confidence level.

Yields of biomass produced by *Phaffia rhodozyma* using glucose at a concentration of 1%, followed the same pattern observed for the parent strain in the previous section of results. Yields of biomass increased up to 120 hours and then began to fall. Maximum yield of biomass obtained was 247.55 mg

cell weight. This is close to the maximum yield of biomass produced by the parent strain in the previous section of results.

The maximum yield of biomass produced by the yeast using a 1.5% carbon source is 25.04 mg greater than the maximum yield obtained from the cells at the lower concentration of glucose.

Biomass production by the yeast followed the same pattern irrespective of the glucose concentration used. In both cultures where no additional carbon was added to the medium, biomass production increased up to 120 hours, then decreased.

In the cultures to which additional carbon was added, the maximum yield of biomass obtained using a 1% carbon source was recorded after 120 hours of growth, and was greater than the maximum yields obtained in either of the two previous runs. The addition of fresh substrate to the culture after 120 hours of growth did not result in an increase in biomass yield. No increase in biomass was obtained after addition of a 1.5% glucose source to the medium. The yields of biomass produced by the yeast decreased after the addition of the fresh substrate (Figure 4.7.2.2).

The results obtained for biomass production indicated that the addition of fresh substrate to the growth medium after 120 hours when the cells have entered the stationary phase, did not result in any increase in biomass yield, irrespective of glucose concentration used.

Growth of *Phaffia rhodozyma* was monitored to determine if the addition of extra carbon would result in an increase in cell number. The results obtained for growth of *Phaffia rhodozyma* in the cultures where no additional carbon was added to the medium, are shown in Figure 4.7.2.3 together with the range of error of the mean, calculated at the 95% confidence level.

Using a 1% carbon source, it can be observed that cells entered the exponential growth phase immediately, and exponential growth continued up to 48 hours when cells entered the stationary phase. Cell growth remained constant after 48 hours. When the concentration of glucose used was increased to 1.5%, higher optical density measurements were recorded.

Figure 4.7.2.1 Biomass production by *Phaffia rhodozyma* grown in shake flask culture using glucose at concentrations of 1% and 1.5%

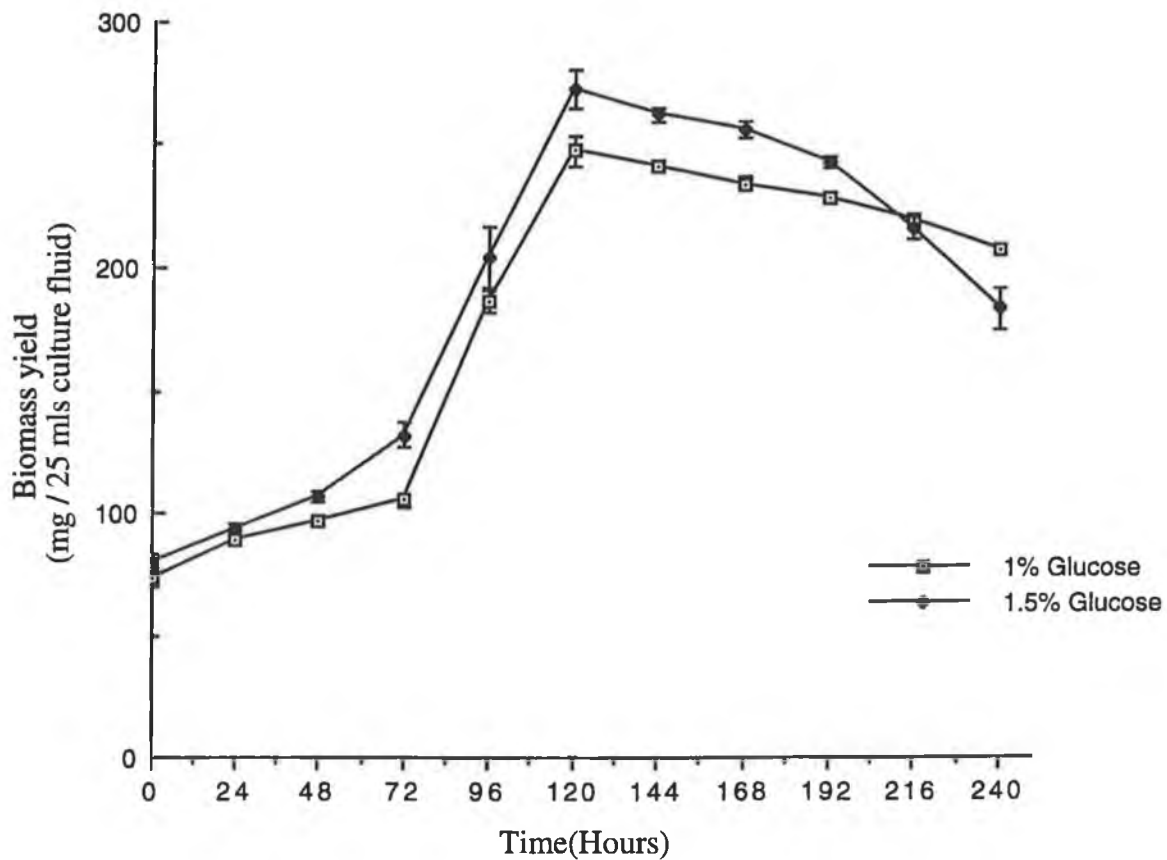

Figure 4.7.2.2 Biomass production by *Phaffia rhodozyma* grown in shake flask culture supplemented after 120 hours with additional glucose at concentrations of 1% and 1.5%

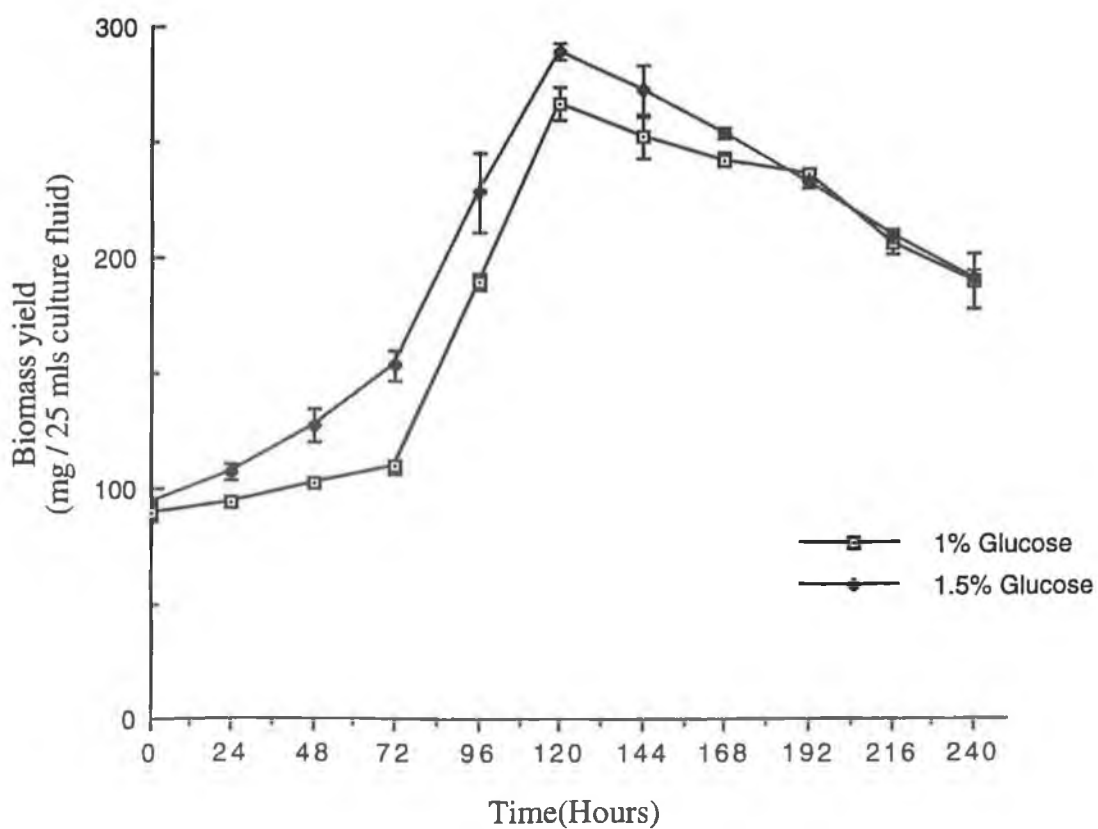

Figure 4.7.2.3 Growth of *Phaffia rhodozyma* in shake flask culture using glucose at concentrations of 1% and 1.5%

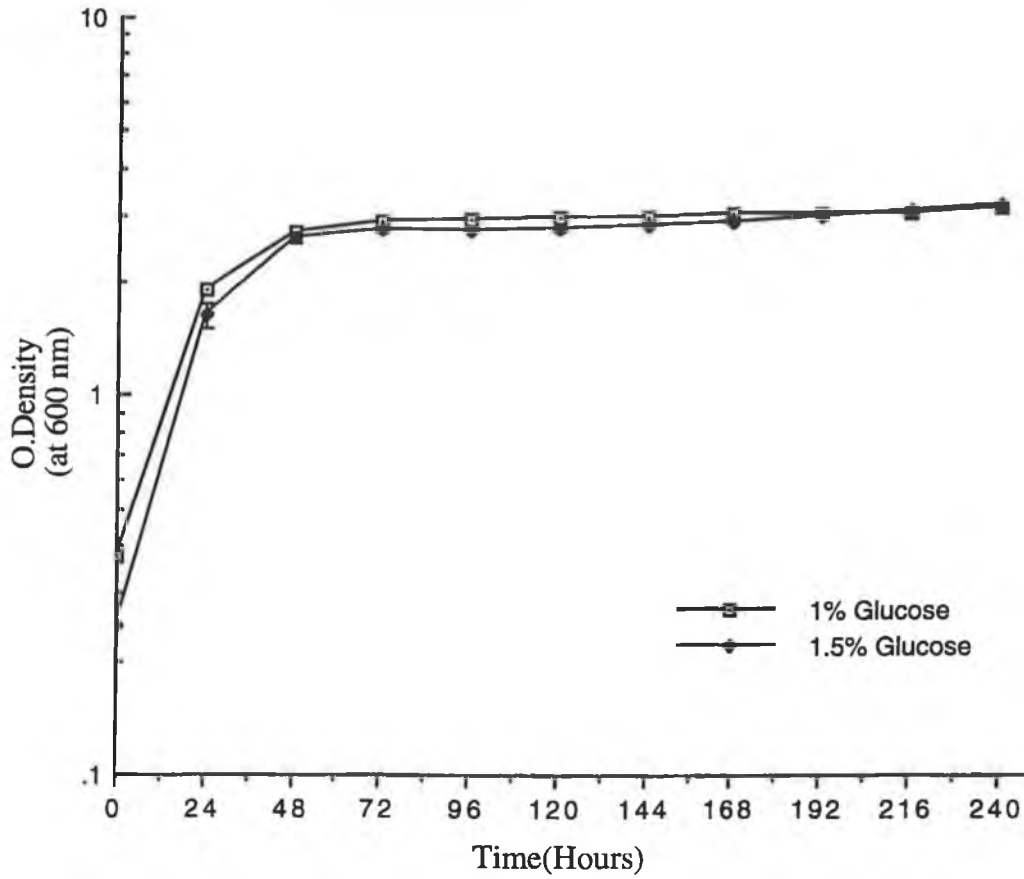
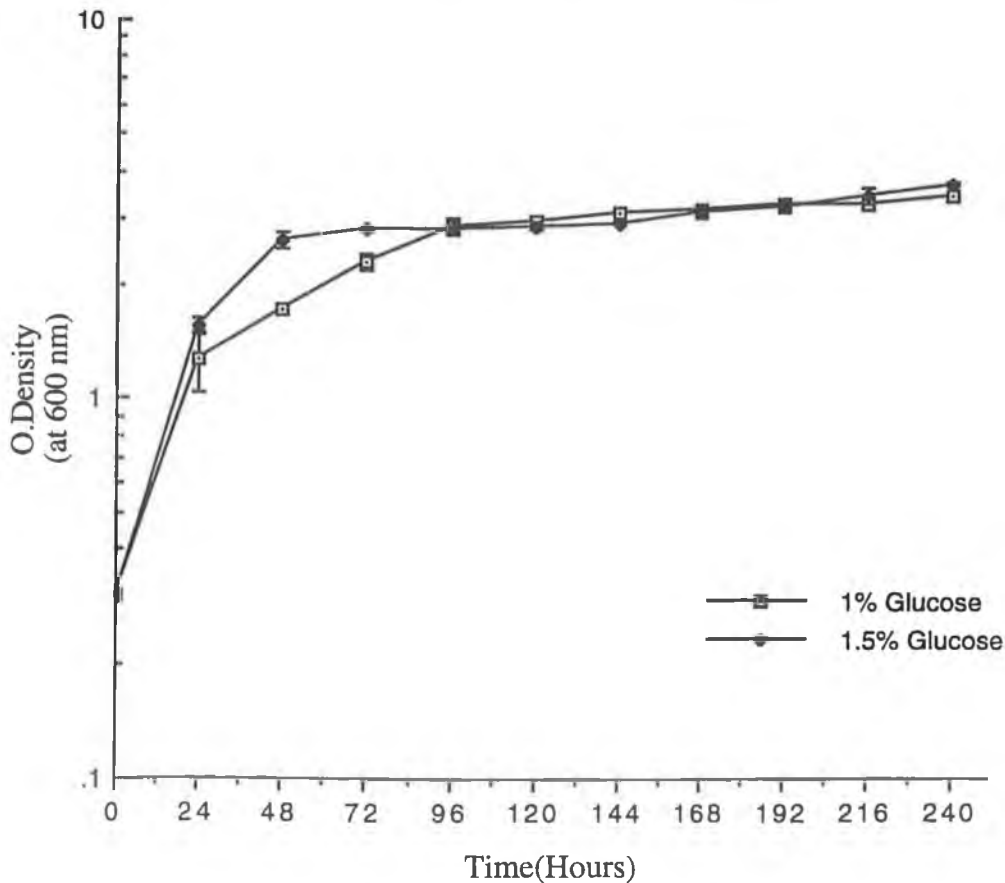

Figure 4.7.2.4 Growth of *Phaffia rhodozyma* in shake flask culture supplemented after 120 hours with glucose at concentrations of 1% and 1.5%



Again, cell numbers increased for the first 48 hours, and remained constant after that time, even though the yields of biomass and pigment production decreased after 120 hours.

The addition of fresh substrate to the culture after 120 hours produced an increase in cell numbers. Growth of *Phaffia rhodozyma* in the cultures supplemented with 1% and 1.5% glucose is shown in Figure 4.7.2.4 .

When 1.5% glucose was used, the same pattern of growth as observed during the control cultivations can be seen, with growth remaining constant after 48 hours. At the lower glucose concentration used, the exponential phase of growth lasted for 96 hours with cells entering the stationary phase after this time. The optical density measurements recorded for both supplemented cultivations are higher than those recorded for the control cultivations, and indicates that the increase in cell numbers is due to the addition of fresh substrate.

Pigment production by *Phaffia rhodozyma* in the cultures where no additional carbon was added to the medium, is shown in Figure 4.7.2.5 , together with the range of error of the mean calculated at the 95% confidence level. Pigment production followed the same pattern at both glucose concentrations used. The yields of astaxanthin produced by the yeast began to increase after an initial lag phase of 24 hours, and continued to increase up to 120 hours when the maximum yield of pigment was produced from the cells. After this time, astaxanthin yields decreased. There was a decrease of 46.03 mg in pigment production between 120 and 144 hours of growth. The decrease in pigment yields after 120 hours occurs with a decrease in biomass production. Pigment production by *Phaffia rhodozyma* is related to growth (Johnson *et al.* 1979), therefore this is to be expected. Higher yields of astaxanthin were obtained using a glucose concentration of 1.5%.

Pigment yields obtained after the addition of 1% and 1.5% glucose to the cultures, are shown in Figure 4.7.2.6 together with the range of error of the mean. Pigment yields produced by the cells during the first 120 hours of the cultivation prior to the addition of 1% glucose, are lower than those obtained during the first 120 hours of the control cultivation, at the same glucose concentration used.

Figure 4.7.2.5 Astaxanthin yields produced by *Phaffia rhodozyma* in shake flask culture using glucose at concentrations of 1% and 1.5%

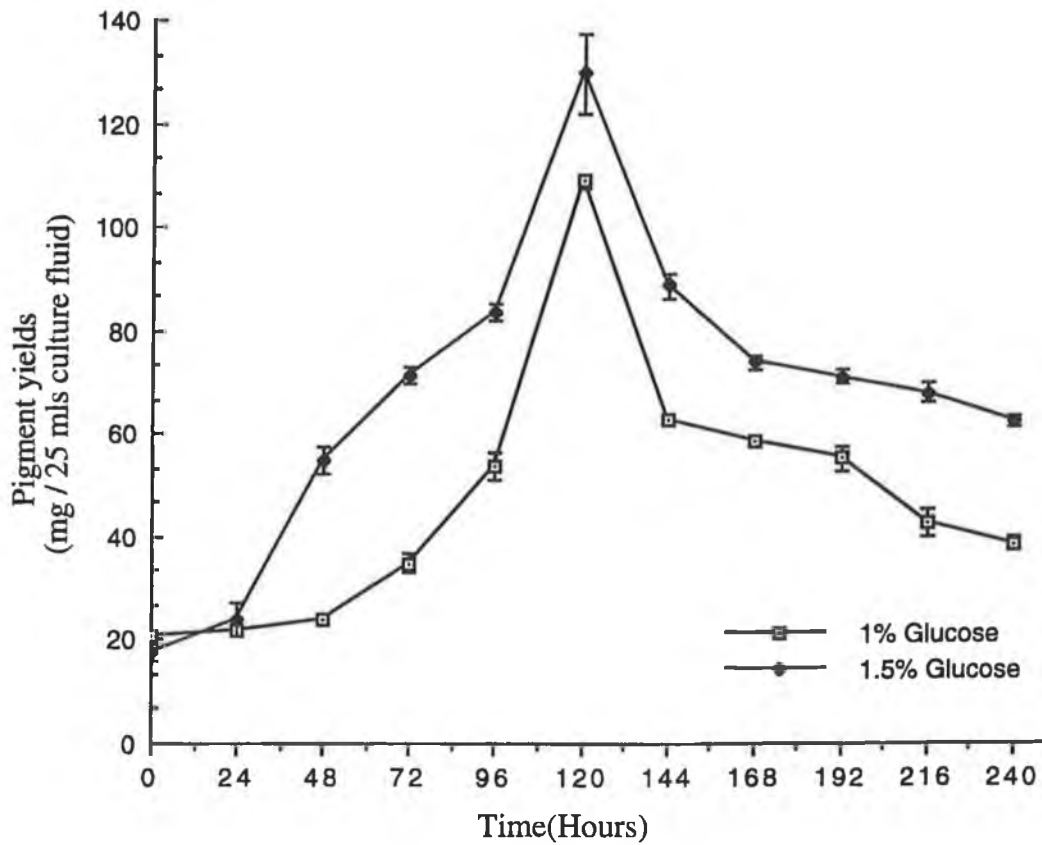
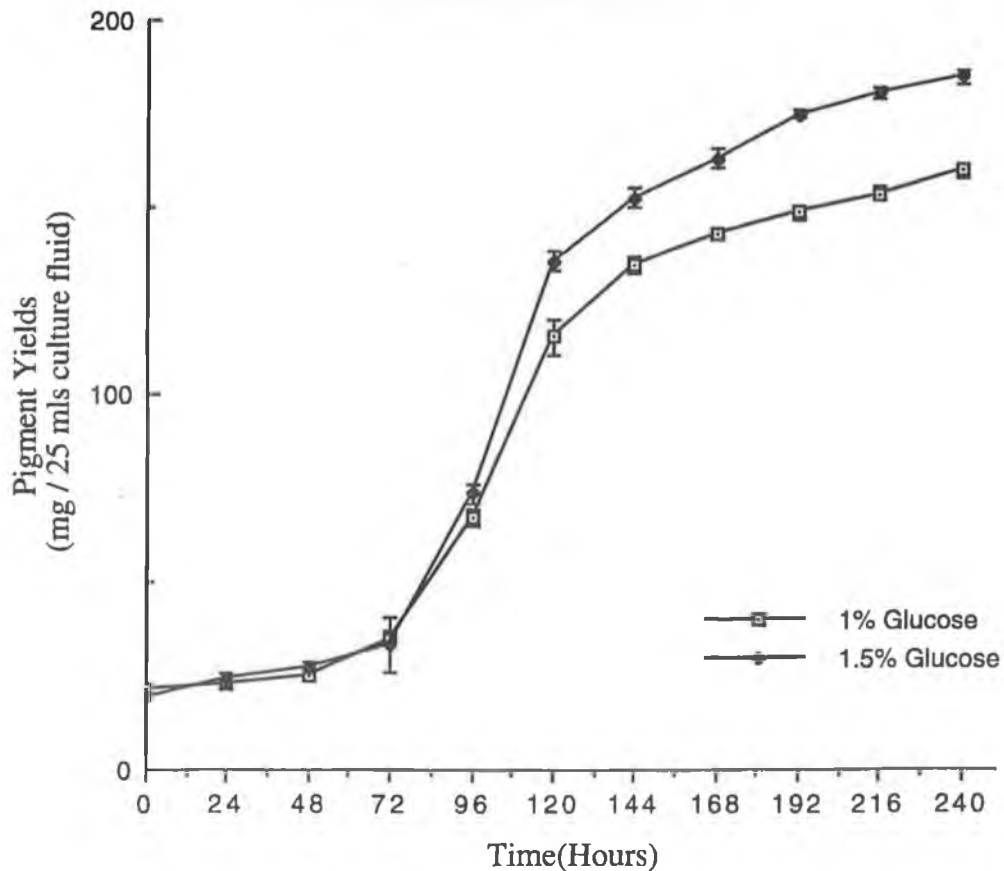

Figure 4.7.2.6 Astaxanthin yields produced by *Phaffia rhodozyma* in shake flask culture supplemented after 120 hours with glucose at concentrations of 1% and 1.5%



However, after the addition of fresh substrate after 120 hours, there was no decrease in pigment production as observed previously. Instead, pigment yields increased up to 240 hours.

The largest increase in pigment yield during a 24 hour period occurs between 96 and 120 hours, when pigment yields from the cells almost doubles. The maximum yield of pigment obtained from the cells was recorded after 240 hours, and was greater than the maximum yields recorded in either of the two control cultivations. These results indicate that the addition of fresh substrate to a culture once the cells have entered the stationary phase of growth, results in an increase in pigment yields.

The addition of fresh substrate to the culture at a concentration of 1.5%, also resulted in increased pigment yields from the cells. As observed previously with the first supplemented culture, the biggest increase in pigment yield occurred between 96 and 120 hours when the yield of pigment obtained from the cells almost doubled. The addition of fresh substrate to the medium resulted in an increase in pigment yields. The yields of pigment produced after 120 hours continued to increase up to 240 hours. Pigment yields obtained during this cultivation are higher than those recorded during any of the three previous cultivations.

Increasing the carbon concentration to 1.5% resulted in an increase in pigment yields, and supplementing a culture with fresh substrate at the higher carbon concentration also produced an increase in pigment yields.

The utilisation of the carbon source by *Phaffia rhodozyma* followed the same pattern for both of the control cultures. The results for carbon consumption during the control runs using 1% and 1.5% glucose, are shown in Figure 4.7.2.7. Glucose consumption by the yeast was very rapid at both concentrations used. After 120 hours of growth, 0.989 mg / ml of the 1% source remained. Even though the carbon concentration was increased by 50%, consumption of the increased carbon source occurred even more rapidly, with 0.187 mg / ml of the 1.5% source remaining after 120 hours of growth, and 0.989 mg / ml of the 1.5% carbon source remaining after this time. If the results for glucose consumption are presented in terms of the percentage of the carbon source remaining in the medium (Figure 4.7.2.9), the pattern of glucose consumption becomes clearer.

Figure 4.7.2.7 Glucose consumption by *Phaffia rhodozyma* grown in shake flask culture using glucose at concentrations of 1% and 1.5%

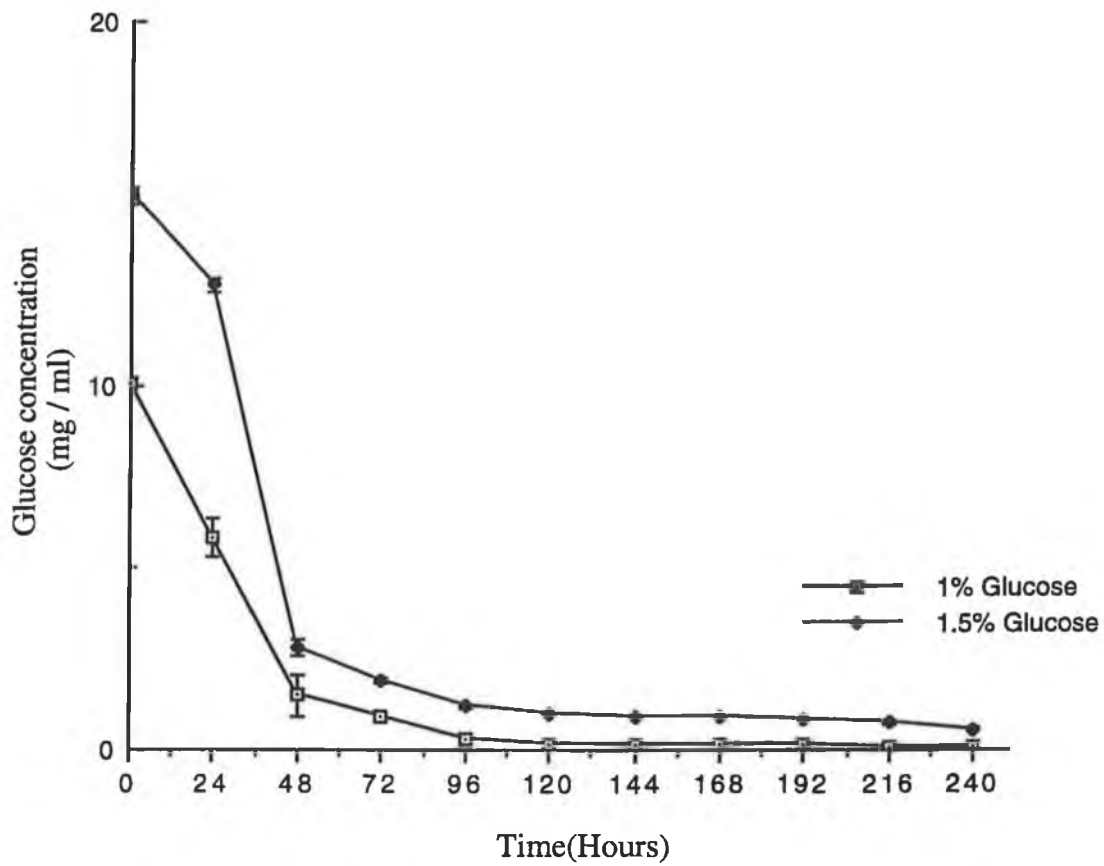

Figure 4.7.2.8 Glucose consumption by *Phaffia rhodozyma* grown in shake flask culture supplemented after 120 hours with glucose at concentrations of 1% and 1.5%

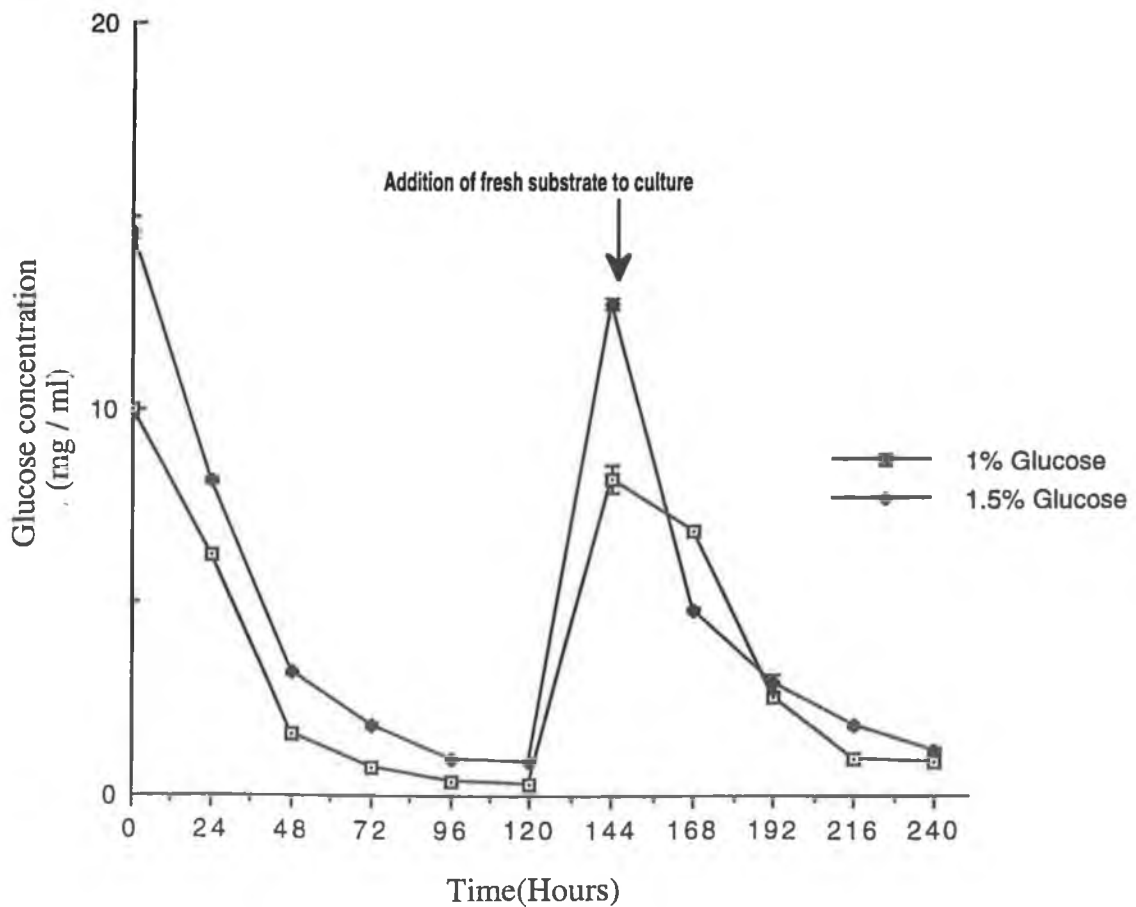

Figure 4.7.2.9 Percentage of glucose remaining in the growth medium during ten days growth of *Phaffia rhodozyma* in shake flask culture

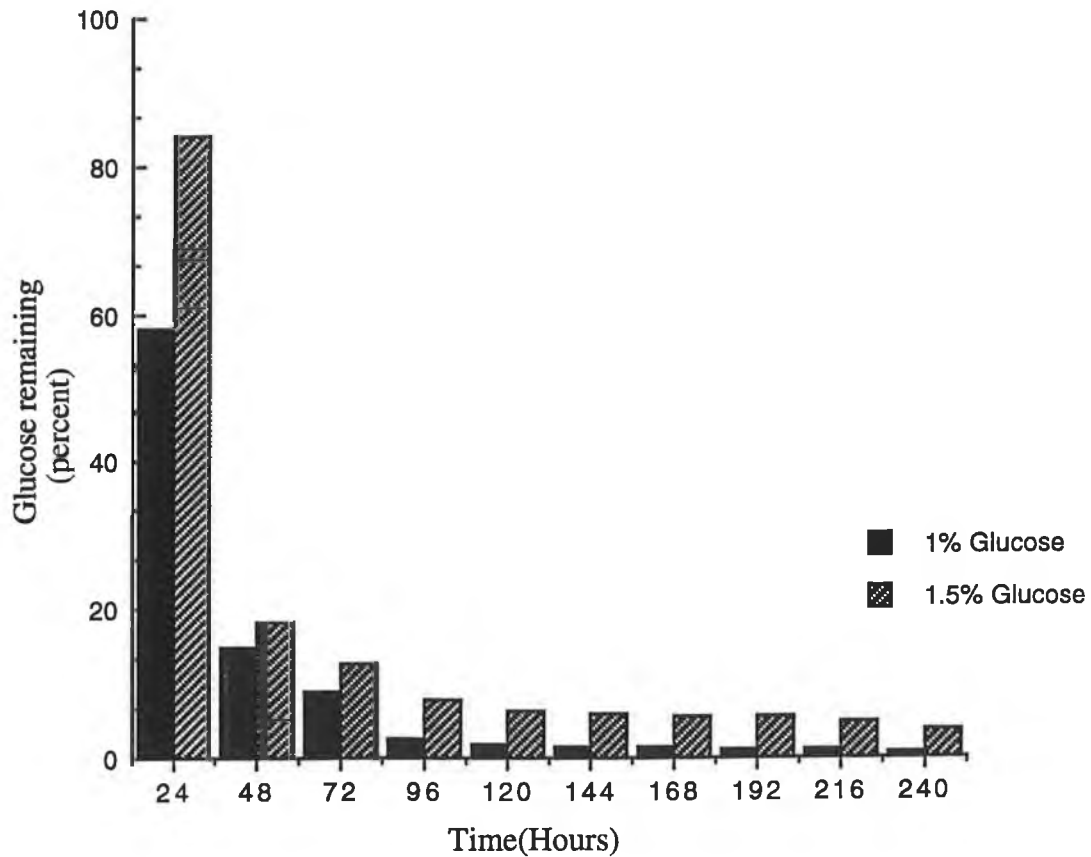
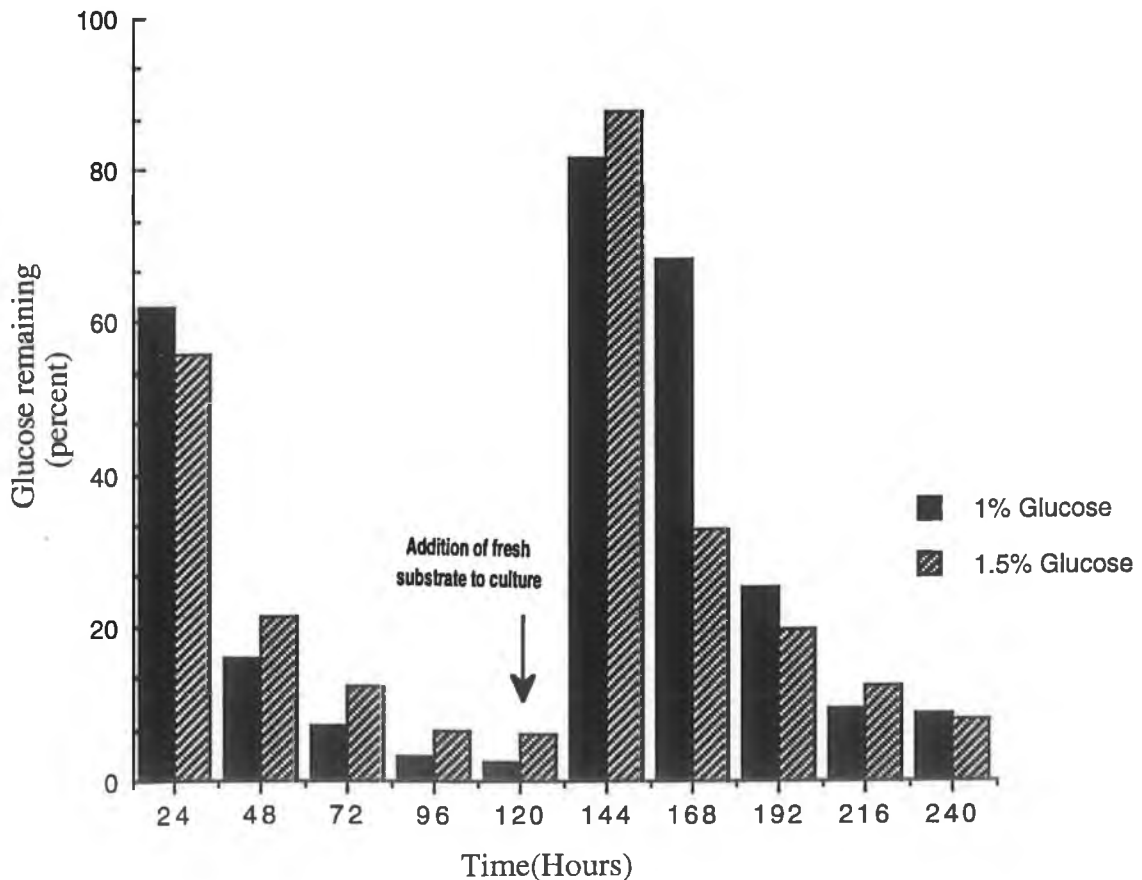

Figure 4.7.2.10 Percentage of glucose remaining in growth medium during growth of *Phaffia rhodozyma* in shake flask culture supplemented after 120 hours with 1% and 1.5% glucose



Consumption of glucose at the higher concentration was less rapid over the first 24 hours of culturing, than at the lower concentration used. 3.65% of the 1.5% carbon source remained in the medium after 240 hours, while 0.88% of the 1% carbon source remained after the same length of time. Four times more of the 1.5% carbon source remained in the medium after 240 hours.

As the yields of biomass and pigment produced by the cells increased, consumption of glucose was very rapid. After 120 hours of growth, when there was maximum pigment production, 98.15% of the 1% carbon source was consumed, while 93.55% of the 1.5% source was consumed. Even though increased pigment and biomass yields were produced at the higher glucose concentration, more of the 1.5% source remained in the medium.

Additional carbon, in the form of glucose at concentrations of 1% and 1.5%, was added to the cultures to determine if glucose consumption after the addition would be as rapid as before supplementation. At the time of supplementation, which was 120 hours, 1.85% of the 1% carbon source remained in the medium, while 6.45% of the 1.5% carbon source remained.

The results shown in Figure 4.7.2.8 show consumption of glucose by *Phaffia rhodozyma* in the supplemented cultures, together with the range of error calculated at the 95% confidence level.

Consumption of the 1% source was very rapid prior to the addition of fresh substrate. After the addition of the glucose to the medium consumption occurred very rapidly. After 120 hours of growth, there was 2.65% of the carbon source remaining. 24 hours after the addition of the fresh glucose, 18.52% of the fresh glucose had been consumed (Figure 4.7.2.10). Consumption of glucose during the next 72 hours was very rapid, and just 9.50% of the additional substrate remained in the medium after 96 hours. Rapid consumption of the additional glucose occurred with increased biomass (Figure 4.7.2.11) and pigment (Figure 4.7.2.15) yields from the cells. The consumption of the 1% carbon source during the control cultivation was very rapid, and once the carbon source was depleted biomass and pigment yields decreased. As more glucose became available to the cells, biomass and pigment yields increased in response to the additional carbon being made available. Cell growth was also observed to increase after the addition of the fresh 1% carbon source (Figure 4.7.2.13).

Figure 4.7.2.11 Biomass production and substrate consumption by *Phaffia rhodozyma* grown in shake flask culture supplemented after 120 hours with 1% glucose

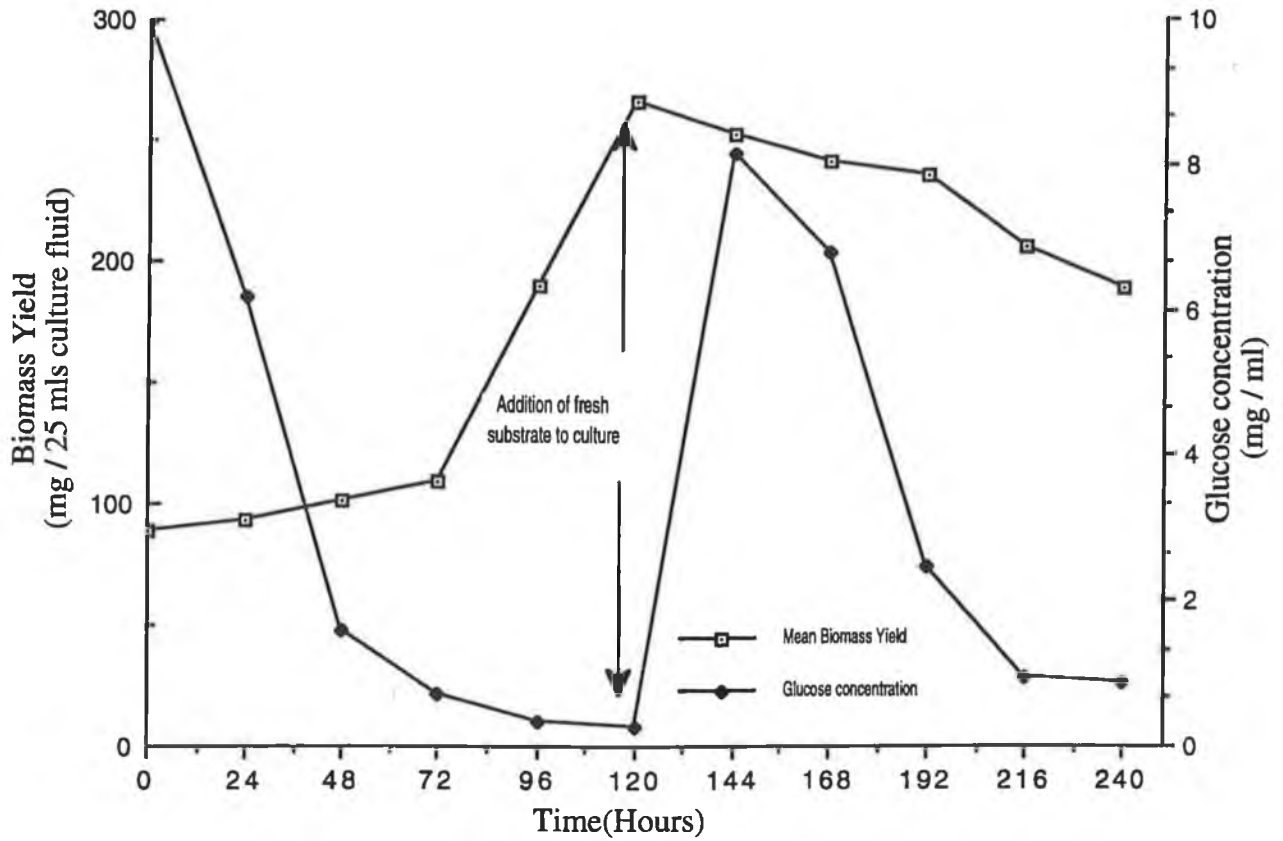

Figure 4.7.2.12 Biomass production and glucose consumption by *Phaffia rhodozyma* grown in shake flask culture supplemented after 120 hours with 1.5% glucose

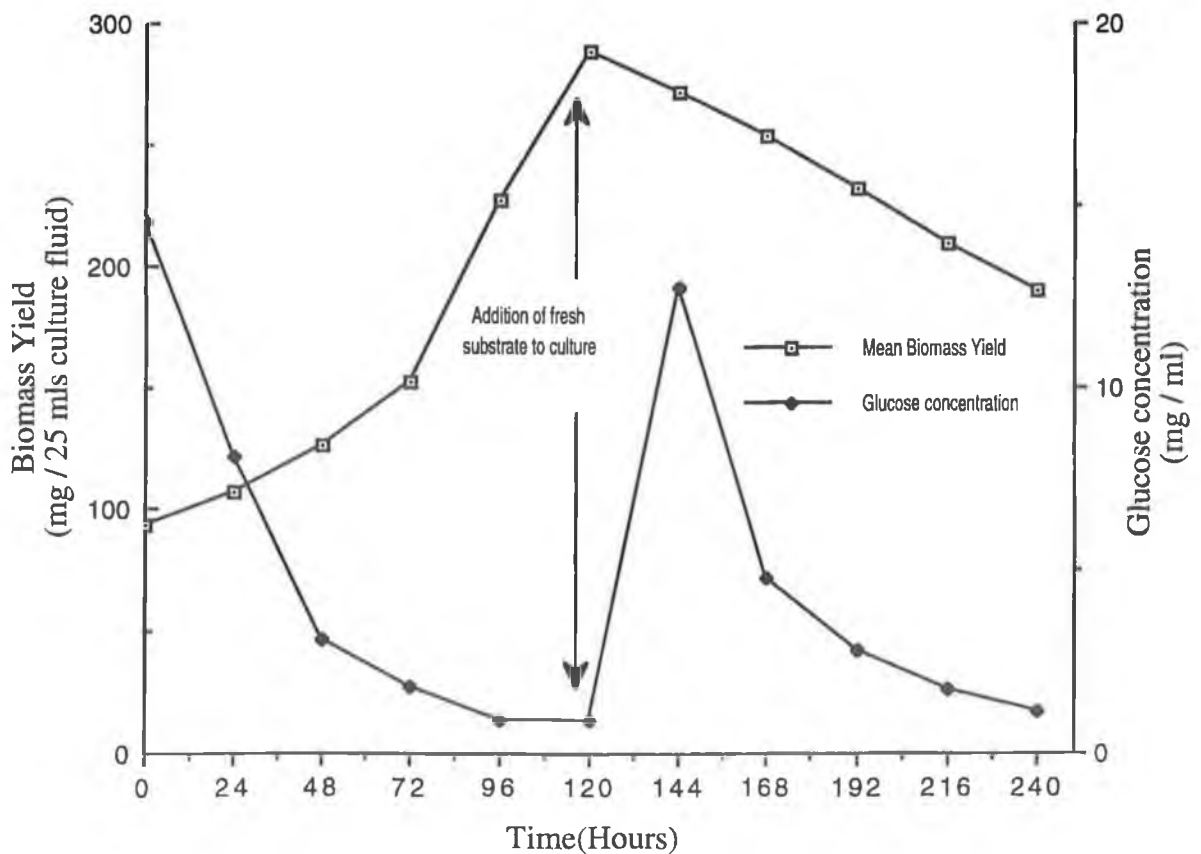

Figure 4.7.2.13 Growth and glucose consumption by *Phaffia rhodozyma* grown in shake flask culture supplemented after 120 hours with 1% glucose

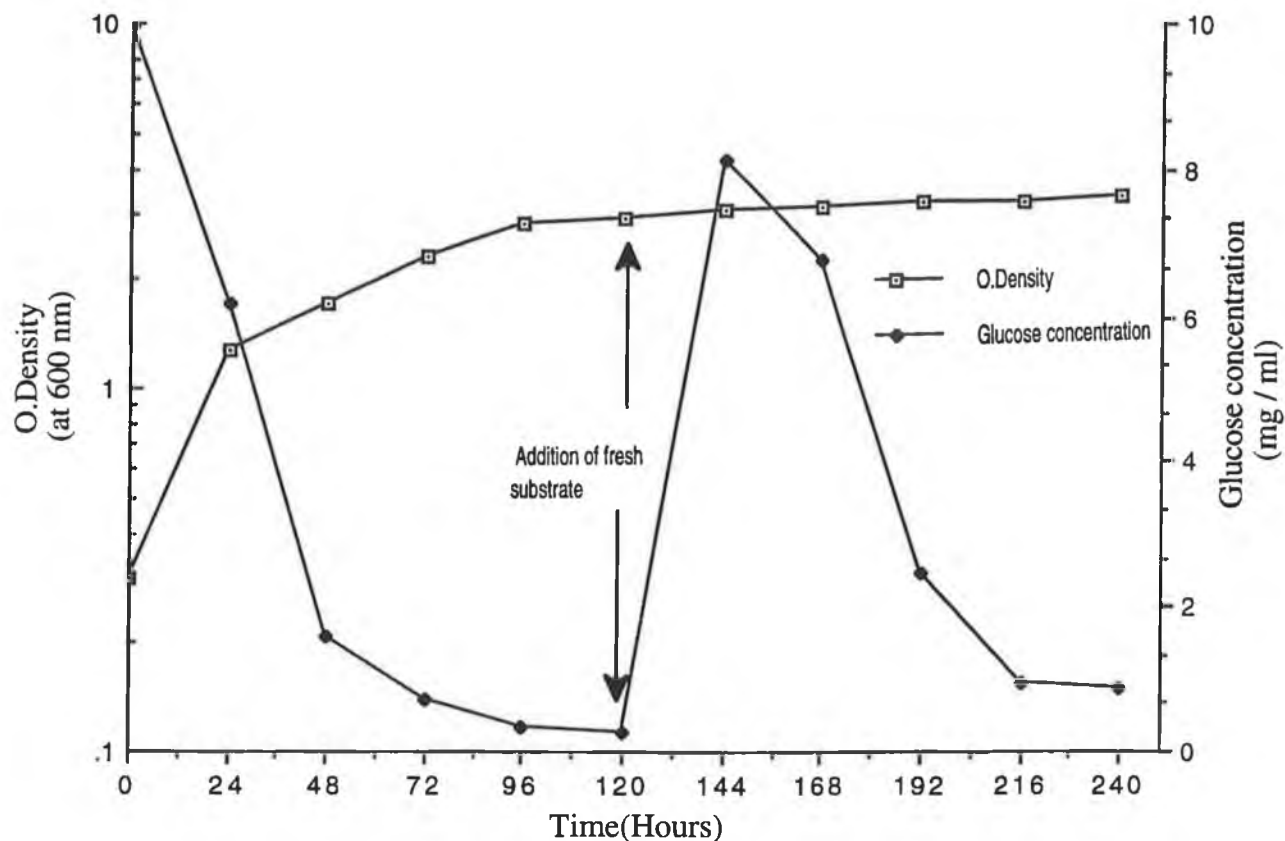

Figure 4.7.2.14 Growth and glucose consumption by *Phaffia rhodozyma* grown in shake flask culture supplemented after 120 hours with 1.5% glucose

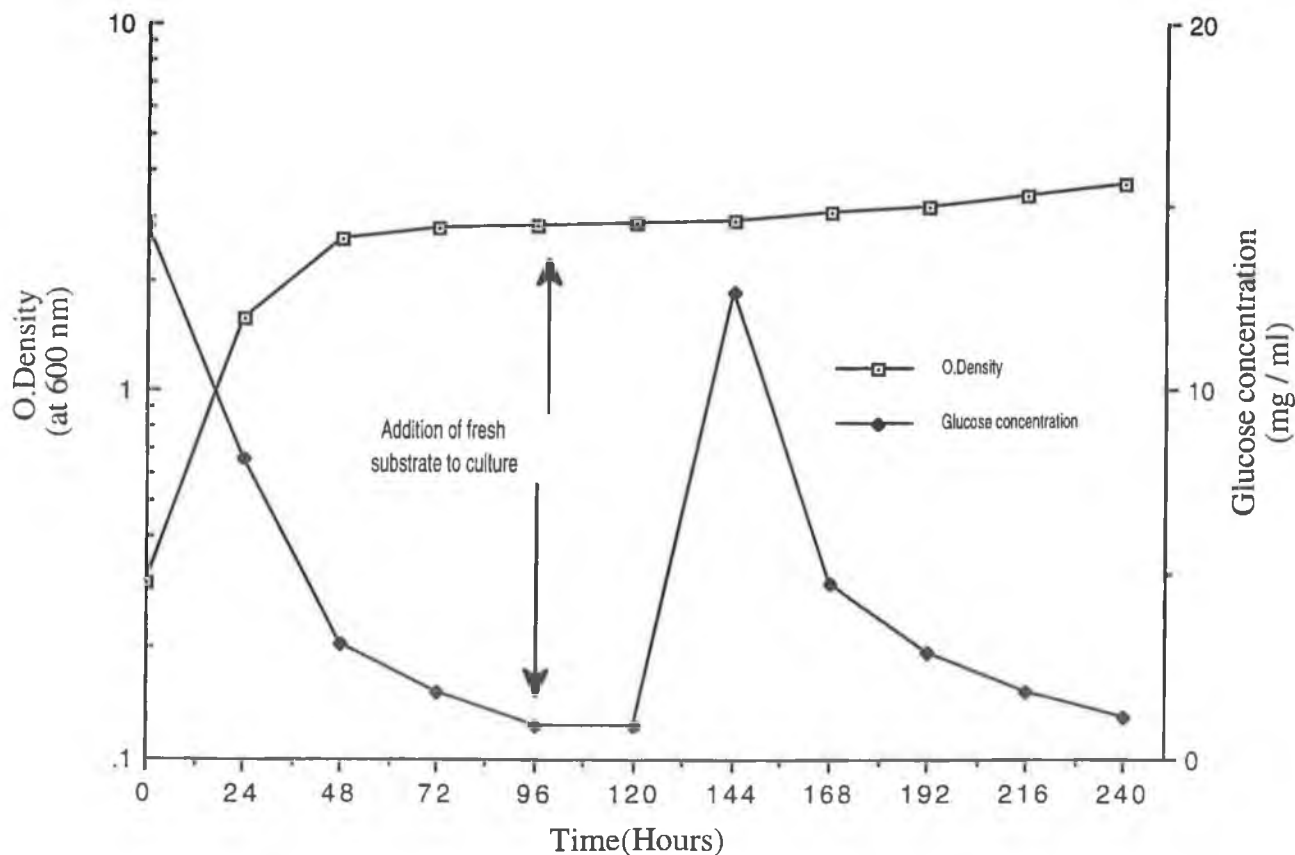

Figure 4.7.2.15 Astaxanthin production and glucose consumption by *Phaffia rhodozyma* grown in shake flask culture supplemented after 120 hours with 1% glucose

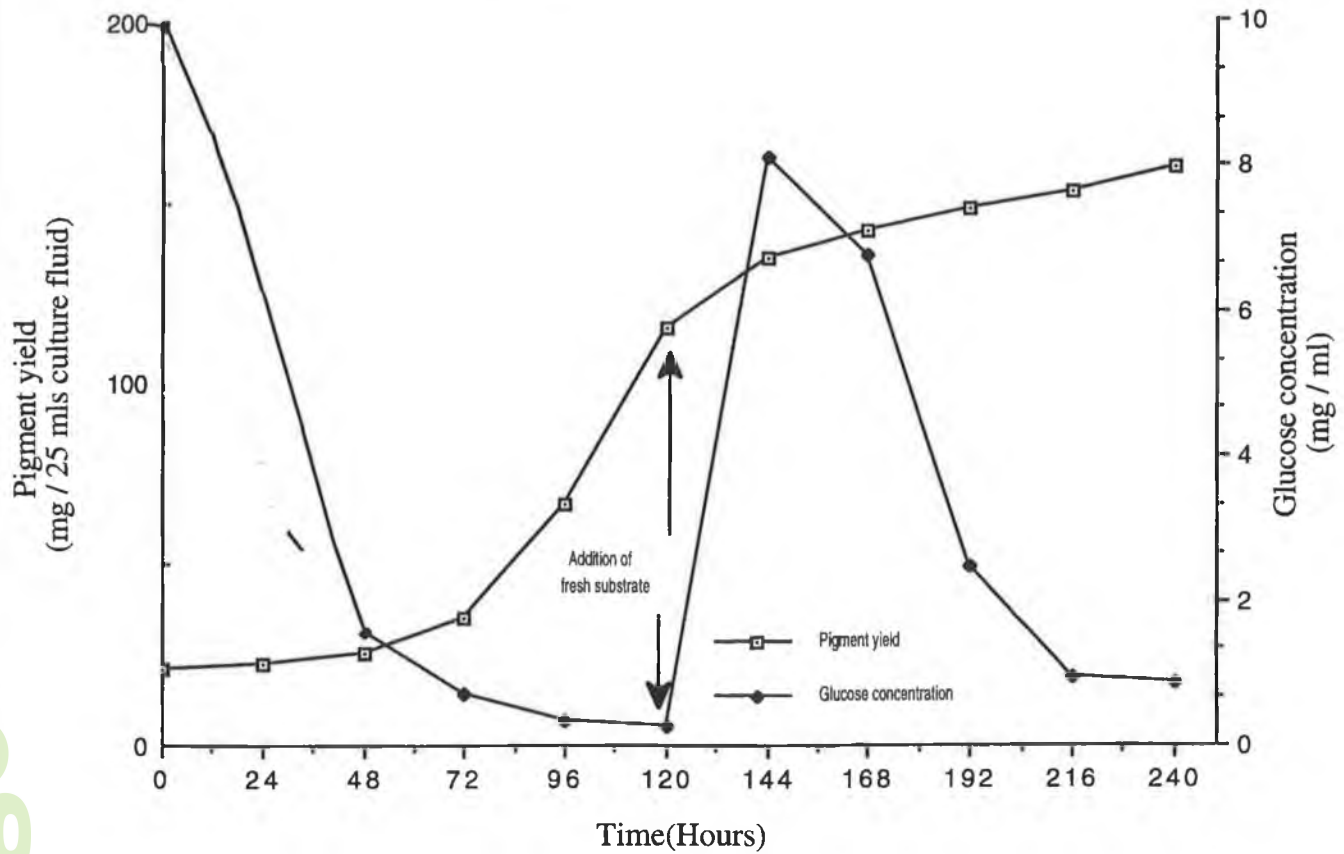
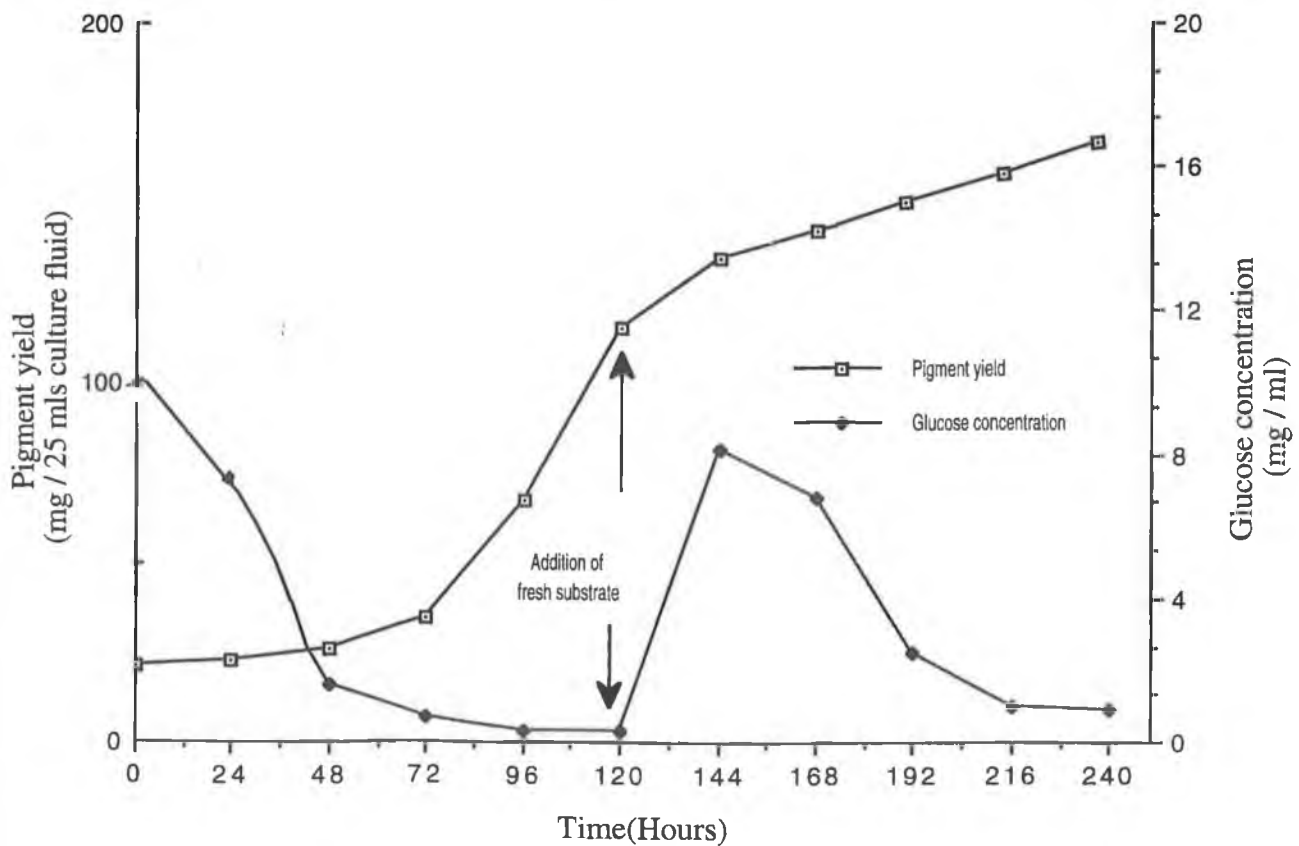

Figure 4.7.2.16 Astaxanthin production and glucose consumption by *Phaffia rhodozyma* grown in shake flask culture supplemented after 120 hours with 1.5% glucose



Consumption of the 1.5% carbon source was rapid prior to the addition of fresh substrate. This followed a similar pattern to that observed previously for the control cultivation using 1.5% glucose. After the addition of fresh substrate, consumption of the fresh glucose was very rapid (Figure 4.7.2.8). 12.49% of the fresh substrate was consumed during the first 24 hours after addition. 72 hours after addition, just 19.48% of the additional carbon remained in the medium (Figure 4.7.2.10). After 240 hours of growth, 92.17% of the additional substrate had been consumed by the yeast. Biomass (Figure 4.7.2.12) and pigment (Figure 4.7.2.16) production increased after the addition of fresh glucose, and continued to increase in line with the rapid consumption of the additional substrate. Higher cell numbers were recorded after the addition of 1.5% glucose (Figure 4.7.2.14).

Consumption of the additional substrate at a glucose concentration of 1.5%, was more rapid than the consumption of the additional 1% carbon source. The opposite was observed to be the case for the control cultivations, with glucose consumption seen to be more rapid at the lower carbon concentration used. 48 hours after the addition of fresh substrate at a concentration of 1.5%, 32.63% remained in the growth medium.

Increased yields of pigment were obtained after the addition of the 1.5% carbon source, and this is to be expected. These results indicate that the addition of fresh substrate to a batch culture of *Phaffia rhodozyma*, after 120 hours growth, when cells are in the stationary growth phase, results in an increase in cell numbers together with an increase in pigment production by the cells.

Statistical analysis was carried out on the results obtained in this section, to determine if correlation existed between;

- (i) pigment and biomass production,
- (ii) pigment production and cell growth,
- (iii) biomass production and cell growth,
- (iv) glucose consumption and pigment production,,
- (v) glucose consumption and biomass production, and

(vi) glucose consumption and cell growth.

Table 4.7.2.1 Correlation coefficients calculated for the control cultivation using a 1% carbon source

Parameters tested	Correlation coefficient (r)	T - Statistic (t)	Accept/reject null hypothesis (r = 0)
Cell growth and biomass production	0.70636	2.82	Reject
Cell growth and pigment production	0.49910	1.63*	Accept
Biomass and pigment production	0.78649	3.60	Reject
Glucose consumption and pigment production	- 0.54489	- 1.84	Reject
Glucose consumption and biomass production	- 0.99059	- 20.47	Reject
Glucose consumption and cell growth	- 0.74326	- 3.14	Reject

(note : * result not statistically significant at the 95% confidence level)

As observed previously in Section 4.6, strong positive correlation can be seen to exist between growth (as measured by optical density) and biomass production. Strong positive correlation also exists between cell growth and pigment production. Positive correlation implies that large values of x (biomass) are associated with large values of y (astaxanthin), and that small values of x are associated with small values of y. Therefore, as biomass yields increase, so do pigment yields, and vice versa. All but one of the results are statistically significant at the 95% confidence level. Positive correlation between growth and both biomass and pigment production is to be expected, since an increase in cell numbers should occur with an increase in biomass and pigment production. Negative correlation is seen to exist between glucose

usage and biomass production, pigment production and growth. Negative correlation implies that large values of y (pigment) are associated with small values of x (glucose). Stronger negative correlation exists between glucose usage and cell growth, than exists between glucose and both pigment and biomass production. This is expected, since nutrient sources are initially utilised solely for growth, with surplus carbon then used to build the basic forty carbon chain of the pigment.

Correlation coefficients were also calculated for the second control cultivation, and the results are presented in Table 4.7.2.2 .

Table 4.7.2.2 Correlation coefficients calculated for the control cultivation using a 1.5% carbon source

Parameters tested	Correlation coefficient (r)	T - Statistic (t)	Accept/reject null hypothesis (r = 0)
Cell growth and biomass production	0.682892	2.64	Reject
Cell growth and pigment production	0.688718	3.69	Reject
Biomass and pigment production	0.829262	4.20	Reject
Glucose consumption and pigment production	- 0.78166	- 3.54	Reject
Glucose consumption and biomass production	- 0.95884	- 9.55	Reject
Glucose consumption and cell growth	- 0.74813	- 3.19	Reject

The same pattern of correlation can be seen to exist here, as was observed for the control cultivation using a 1% carbon source. Again, there is strong positive correlation between pigment production and growth, and between cell growth and both biomass and pigment production. Negative correlation exists between glucose usage and cell growth, biomass production, and pigment

production. As observed in Table 4.7.2.1, stronger negative correlation exists between consumption and cell growth (as measured by optical density), than exists between glucose usage and both biomass and pigment production. All the correlation coefficients are statistically significant at the 95% confidence level. Table 4.7.2.3 shows the correlation coefficients calculated for the supplemented cultivation where a 1% carbon source was used.

Table 4.7.2.3 Correlation coefficients calculated for the supplemented cultivation where a 1% carbon source was used

Parameters tested	Correlation coefficient (r)	T - Statistic (t)	Accept/reject null hypothesis (r = 0)
Cell growth and biomass production	0.654119	2.45	Reject
Cell growth and pigment production	0.749353	3.20	Reject
Biomass and pigment production	0.864622	4.87	Reject
Glucose consumption and pigment production	- 0.10895	- 0.52*	Accept
Glucose consumption and biomass production	- 0.65364	- 2.44	Reject
Glucose consumption and cell growth	- 0.15868	- 0.45*	Accept

(note : * result not statistically significant at the 95% confidence level)

Two of the results obtained here are not statistically significant at the 95% confidence level. Low negative correlation existing between glucose usage and both biomass and pigment production is surprising, since the addition of fresh substrate produced an increase in pigment production by the cells. However, strong negative correlation is seen to exist between glucose usage and cell growth, as expected. Strong positive correlation exists between cell growth, and both biomass and pigment production. This follows a similar pattern observed for correlation between glucose usage and biomass and pigment

production observed for the control cultivation using the same concentration of glucose. The correlation coefficients were also calculated for the supplemented cultivation using a 1.5% carbon source (Table 4.7.2.4).

Table 4.7.2.4 Correlation coefficients calculated for the supplemented cultivation using a 1.5% carbon source

Parameters tested	Correlation coefficient (r)	T - Statistic (t)	Accept/reject null hypothesis (r = 0)
Cell growth and biomass production	0.654119	4.26	Reject
Cell growth and pigment production	0.749353	4.98	Reject
Biomass and pigment production	0.864622	3.38	Reject
Glucose consumption and pigment production	- 0.10895	- 0.90*	Accept
Glucose consumption and biomass production	- 0.65364	- 2.12	Reject
Glucose consumption and cell growth	- 0.15868	- 0.45*	Accept

(note : * result not statistically significant at the 95% confidence level)

As observed previously for the supplemented cultivation using 1% glucose, strong correlation exists between cell growth and both biomass and pigment production. However, two correlation coefficients obtained are not statistically significant at the 95% confidence level. Low negative correlation is seen to exist between glucose usage and cell growth, and glucose usage and pigment production. This follows the same pattern observed for the first supplemented cultivation. A possible explanation for this is that negative correlation implies that large values of y (pigment) tend to go with small values of x (glucose). As glucose was added to the medium after 120 hours, the levels of glucose in the medium increased as a result. The negative correlation theory would therefore not be applicable at this point, since large values of pigment occur with small

values of glucose, but only up to the point of addition. Positive correlation would then come into play for a short period, as large values of pigment would occur with large values of glucose. Once the additional glucose began to be consumed, negative correlation would again be applicable. This could explain why the negative correlation coefficients obtained between glucose consumption and pigment production, and glucose usage and cell growth. However, this theory is weakened by the fact that the correlation existing between glucose consumption and biomass production is statistically significant.

4.8 Cultivation of the parent strain (NCYC 874) and a mutant strain (NRRL-Y-18734) of *Phaffia rhodozyma* in a 2L laboratory fermenter

4.8.1 Introduction

The research carried out in this project concentrated on growth and pigmentation of *Phaffia rhodozyma* in batch culture using shake flasks, with a view to investigating biomass and pigment produced by the parent strain and a mutant strain of the yeast, and the role that consumption of the carbon and nitrogen source played with regard to biomass and pigment production.

Results obtained in the Section 4.6 of this research have indicated that the parent strain ceases biomass and pigment production after 120 hours, while the mutant strain continues to produce both pigment and biomass after this time. Culturing both strains of the yeast in a fed batch system did not produce an increase in biomass, but did result in an increase in both cell numbers and pigment yields. The next step in this research involved scaling up from the shake flask to a laboratory fermenter. The advantages of using the fermenter include;

- the parent and mutant strain of the yeast can be cultured under more controlled conditions than could be maintained in the shake flask system of culture, and
- allows the yields of biomass and pigment produced by the parent and mutant strain of the yeast in a system that has twenty times the volume of growth media, than the shake flask system.

Cultivation of the yeast in the fermenter was also carried out to determine if any significant change in the pattern of biomass and pigment production, or growth would be observed, to that previously observed with the shake flask culture of the organism.

4.8.2 Analysis of Results

Fermenter culture conditions were monitored throughout the cultivation of the parent strain (NCYC 874), and this included monitoring any changes in temperature, pH, rpm and dissolved oxygen. A summary of the culture

conditions monitored during the cultivation of the parent strain is given in Table 4.8.2.1 .

Table 4.8.2.1 Culture conditions during the cultivation of the parent strain of *Phaffia rhodozyma* in a 2l laboratory fermenter

Time (Hours)	Temperature (°C)	pH (units)	Dissolved Oxygen (percent)	Agitation (rpm)
0	22	4.01	96	200
9	22	4.07	82	220
20	21	4.14	75	280
24	21	4.10	70	310
41	22	4.00	64	320
48	22	3.89	58	500
65	21	2.35	57	550
72	20	4.48	55	610
90	21	3.99	50	630
96	22	4.14	51	680
120	20	5.15	50	710
140	21	5.08	52	640
160	21	5.10	50	600
170	22	4.90	54	580
180	20	4.50	50	520

During the cultivation of the parent strain in the fermenter, the temperature remained between 20°C and 22°C. The pH of the culture was adjusted when it fell below 4.0. The agitation speed increased as the growth of the yeast increased. As the yeast grew in the culture, the dissolved oxygen fell. However, the dissolved oxygen concentration remained at 50 percent, or above, during culturing of the parent strain.

A mutant strain of *Phaffia rhodozyma* (NRRL-Y-18734) was also cultured in the fermenter. Culture conditions were monitored during the run, which lasted 180 hours, and are shown in Table 4.8.2.2

Table 4.8.2.2 Culture conditions during the cultivation of the mutant strain of *Phaffia rhodozyma* in a 2l laboratory fermenter

Time (Hours)	Temperature (°C)	pH (units)	Dissolved Oxygen (percent)	Agitation (rpm)
0	20	4.10	98	210
9	21	4.21	96	225
20	21	4.20	94	275
24	22	4.35	90	300
41	21	4.10	88	340
48	22	3.95	86	370
65	22	4.35	80	580
72	21	4.65	74	610
90	22	4.80	68	730
96	21	4.40	60	850
120	21	4.14	55	880
140	22	4.20	52	900
160	22	3.92	50	740
170	21	3.75	55	650
180	21	3.95	62	600

Biomass production by the parent strain cultured in the fermenter is shown in Figure 4.8.2.1, together with the range of error of the mean, calculated at the 95% confidence level.

It can be observed that biomass growth begins after a lag phase of 12 hours, which was similar to the length of the lag phase reported by Johnson *et al.* (1979). Biomass production remains steady after 120 hours, when cells are in the stationary phase of growth. An increase of 0.162 g cell weight is produced every 24 hours after this time. The biggest increase in biomass production occurs between 48 and 72 hours, when cells enter the exponential growth phase. An increase of 1.53 g cell weight was recorded. The statistical range of error calculated for these results is lower than the range of error obtained for biomass production by the parent strain in shake flask culture.

The parent strain produced increased yields of biomass during 180 hours of growth. Biomass yields produced by the parent strain grown in shake flask

culture decreased after 120 hours. The pattern of increased biomass production observed here, could be due to increased oxygen available in the culture vessel. The maximum yield of biomass produced by the parent strain grown in the fermenter was 6.923 g/l cell weight.

Yields of biomass produced by the mutant strain increase greatly during the first 120 hours of growth (Figure 4.8.2.1). The biggest increase in biomass production occurs between 48 and 72 hours of growth, when an increase of 1.3 g cell weight was recorded. On average, the yields of biomass produced by the mutant strain are between two and four times greater than the yields produced by the parent strain. Biomass production by the mutant strain grown in the fermenter, follows the same pattern observed for biomass production during shake flask culture. In both cases, biomass yields increase over 180 hours.

Growth (as measured by optical density) of the parent strain in the fermenter was also monitored (Figure 4.8.2.2). As observed with biomass production, cell growth increases over 180 hours. Cell numbers are higher than those recorded when the parent strain as grown in shake flask culture. After an initial lag phase of 12 hours cells enter the exponential phase. After 72 hours of growth, cells enter the stationary phase, and cell growth remains steady during this time. A shorter exponential phase of growth was observed when the parent strain was grown in the fermenter. The exponential phase of growth lasted up to 120 hours when the parent strain was grown in shake flask culture.

Growth of the mutant strain was also monitored. The optical density measurements recorded during this run are shown Figure 4.8.2.2 , together with the range of error of the mean.

As observed previously with biomass production, there is an increase in cell growth over 180 hours. Cells enter the exponential phase of growth immediately, and there is a marked increase in cell growth between 24 and 72 hours as biomass and pigment yields are increasing. As the yields of biomass and biomass begin to level off, cell growth remains fairly constant. The optical density measurements recorded during this run are higher than those recorded when the mutant strain was grown in shake flask culture, indicating increased cell growth in the fermenter system.

Figure 4.8.2.1 Biomass production by the parent strain (NCYC 874) and a mutant strain (NRRL-Y-18734) of *Phaffia rhodozyma* grown in batch culture using a 2L fermenter

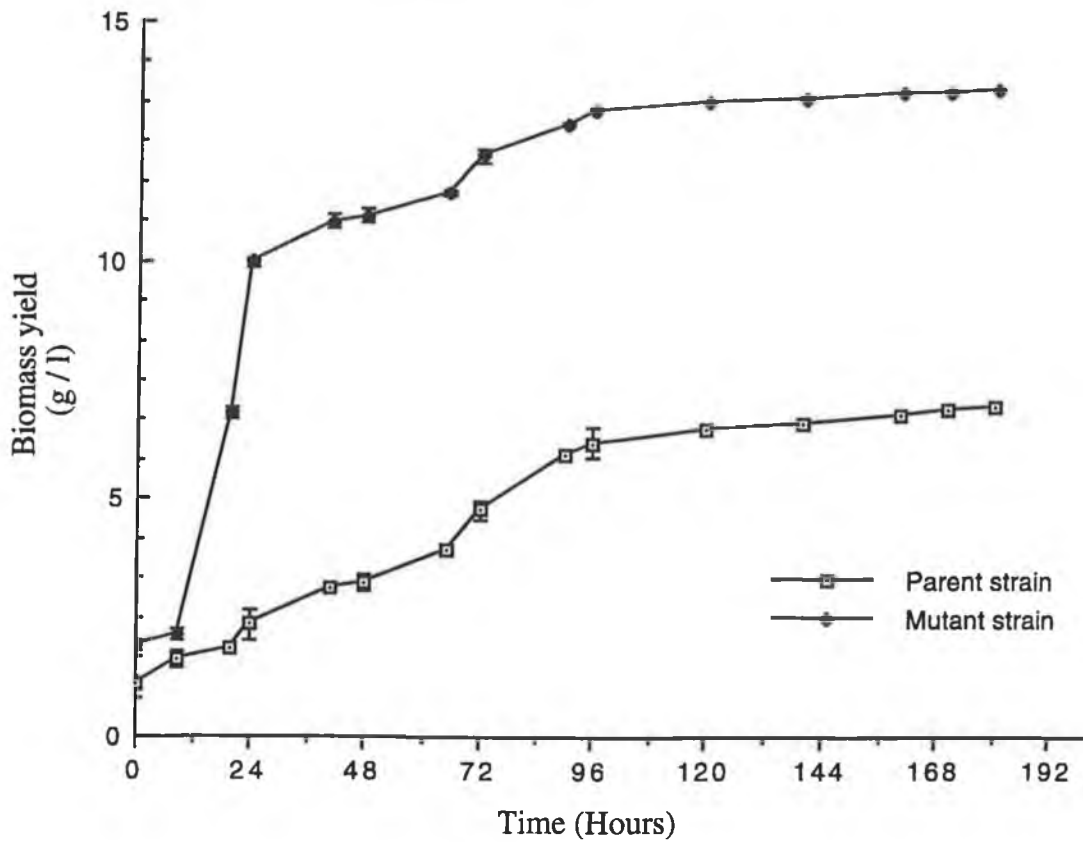

Figure 4.8.2.2 Growth of the parent strain (NCYC 874) and a mutant strain (NRRL-Y-18734) of *Phaffia rhodozyma* in batch culture using a 2L fermenter

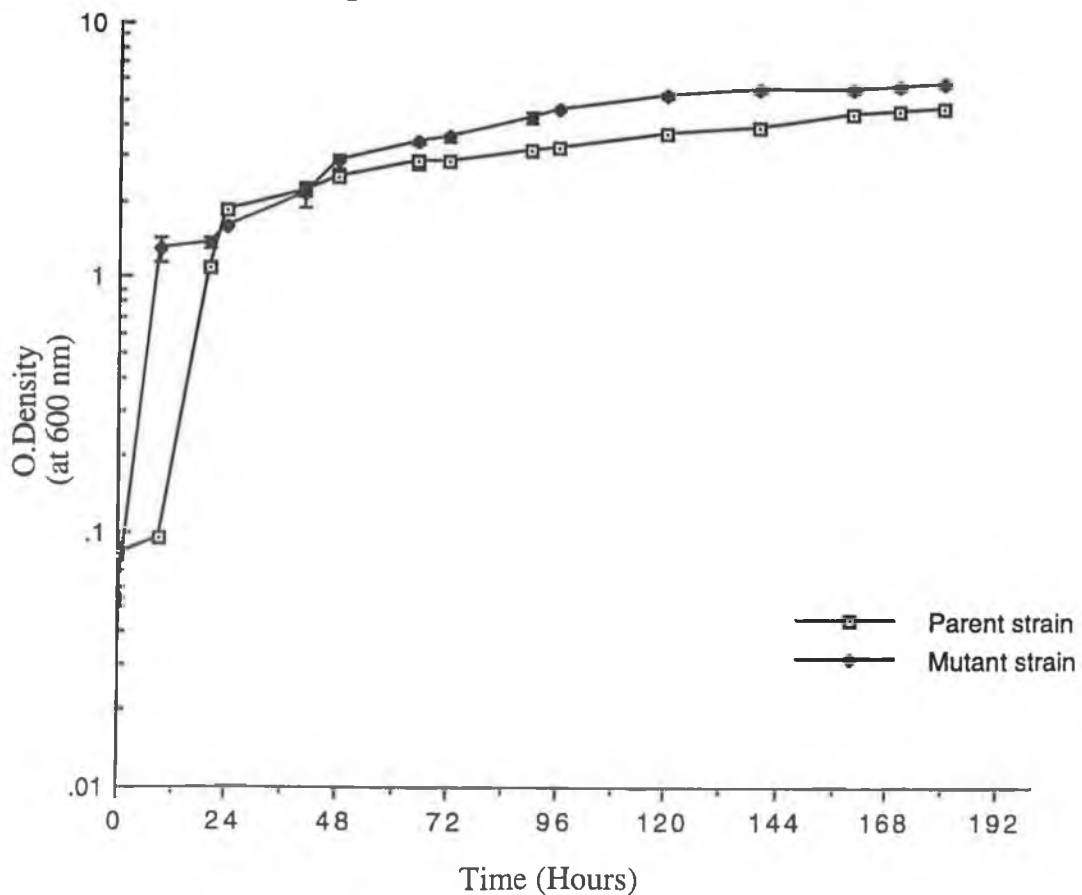
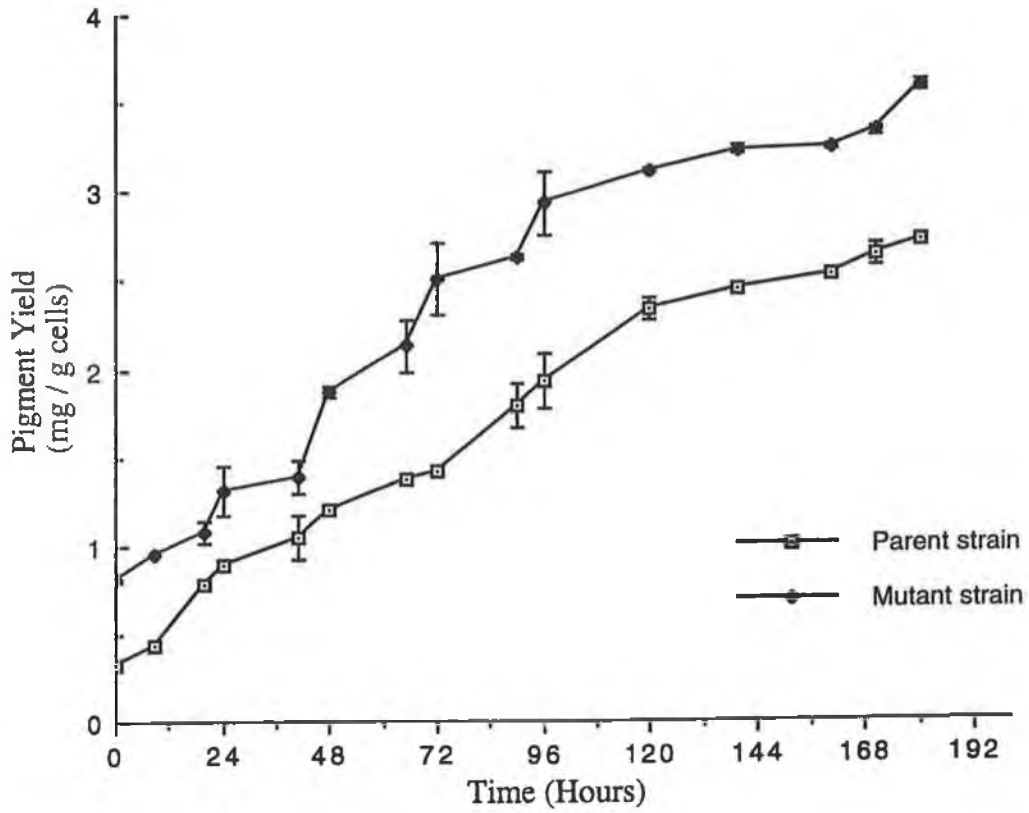

Figure 4.8.2.3 Astaxanthin production by the parent strain (NCYC 874) and a mutant strain (NRRL-Y-18734) of *Phaffia rhodozyma* grown in batch culture using a 2L fermenter



Pigment production by the parent strain in fermenter culture is shown in Figure 4.8.2.3 .

Pigment yields obtained during this run are higher than those cited in the literature (Prevatt *et al.* 1991). This is consistent with the error expected using the simple spectrophotometric analysis of the cells suspended in acetone (Johnson *et al.* 1991).

As observed previously with biomass production, pigment production by the cells begins after an initial lag phase of 12 hours. Pigment production increases up to 180 hours, when a maximum pigment yield of 2.7122 mg per g cells was recorded. The biggest increase in pigment yield occurs between 96 and 120 hours of growth, when an increase of 0.4018 mg was recorded. The biggest increase in biomass yields occurred earlier, between 72 and 96 hours of growth.

Pigment yields produced by the mutant strain in the fermenter culture are shown in Figure 4.8.2.3 . As observed with biomass production, pigment yields produced by the mutant strain increase over 180 hours. As cell growth occurs exponentially, pigment production increases. The biggest increase in pigment yield during any 24 hour period, occurs between 48 and 72 hours of growth, when an increase of 0.64 mg pigment was recorded. The biggest in pigment yield produced by the parent strain occurs 24 hours later, between 72 and 96 hours of growth. As the mutant strain grew at a faster rate than the parent strain, this is to be expected.

Consumption of the carbon source by the parent strain during cultivation in the fermenter was also investigated. Glucose consumption by the parent strain is shown in Figure 4.8.2.5, together with the range of error of the mean, calculated at the 95% confidence level.

Glucose consumption by the parent strain follows the same pattern as previously observed during shake flask cultivation of the yeast (Figure 4.6.2.4). Glucose consumption is rapid for the first 72 hours, when cells are in the exponential phase of growth. During this time biomass (Figure 4.8.2.5) and pigment (Figure 4.8.2.6) yields produced by the cells are increasing. After 72 hours consumption of glucose remains steady. The same pattern can be observed for cell growth and glucose consumption (Figure 4.8.2.7).

Figure 4.8.2.4 Glucose consumption by the parent strain (NCYC 874) and a mutant strain (NRRL-Y-18734) of *Phaffia rhodozyma* after 180 hours growth in a 2L fermenter

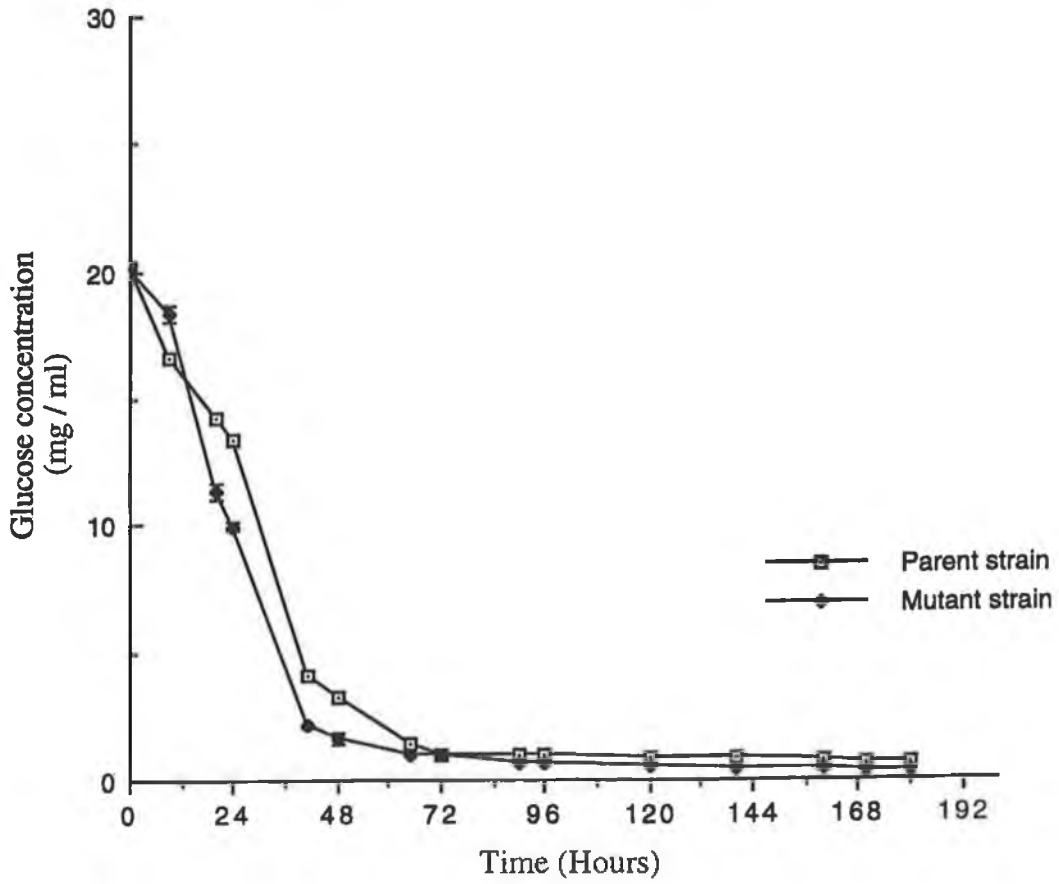

Figure 4.8.2.5 Biomass production and glucose consumption by the parent strain (NCYC 874) of *Phaffia rhodozyma* grown in a 2L fermenter

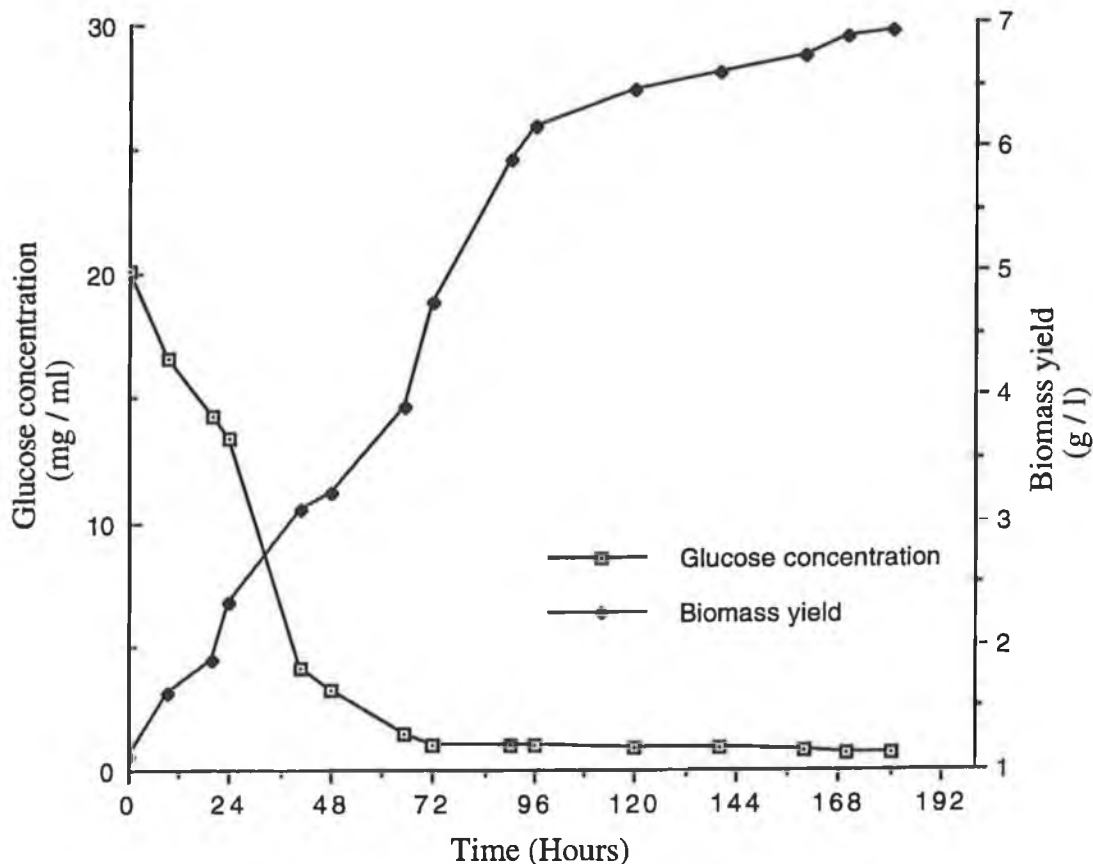

Figure 4.8.2.6 Astaxanthin production and glucose consumption by the parent strain (NCYC 874) of *Phaffia rhodozyma* grown in a 2L fermenter

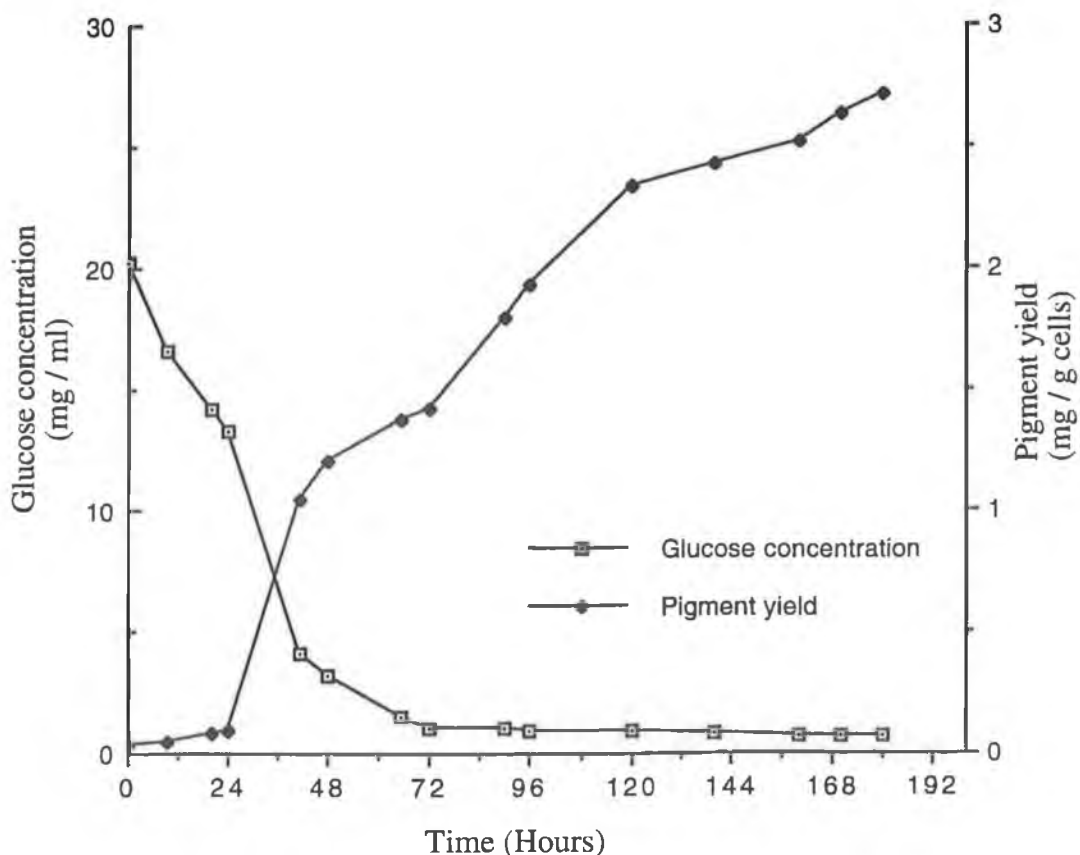
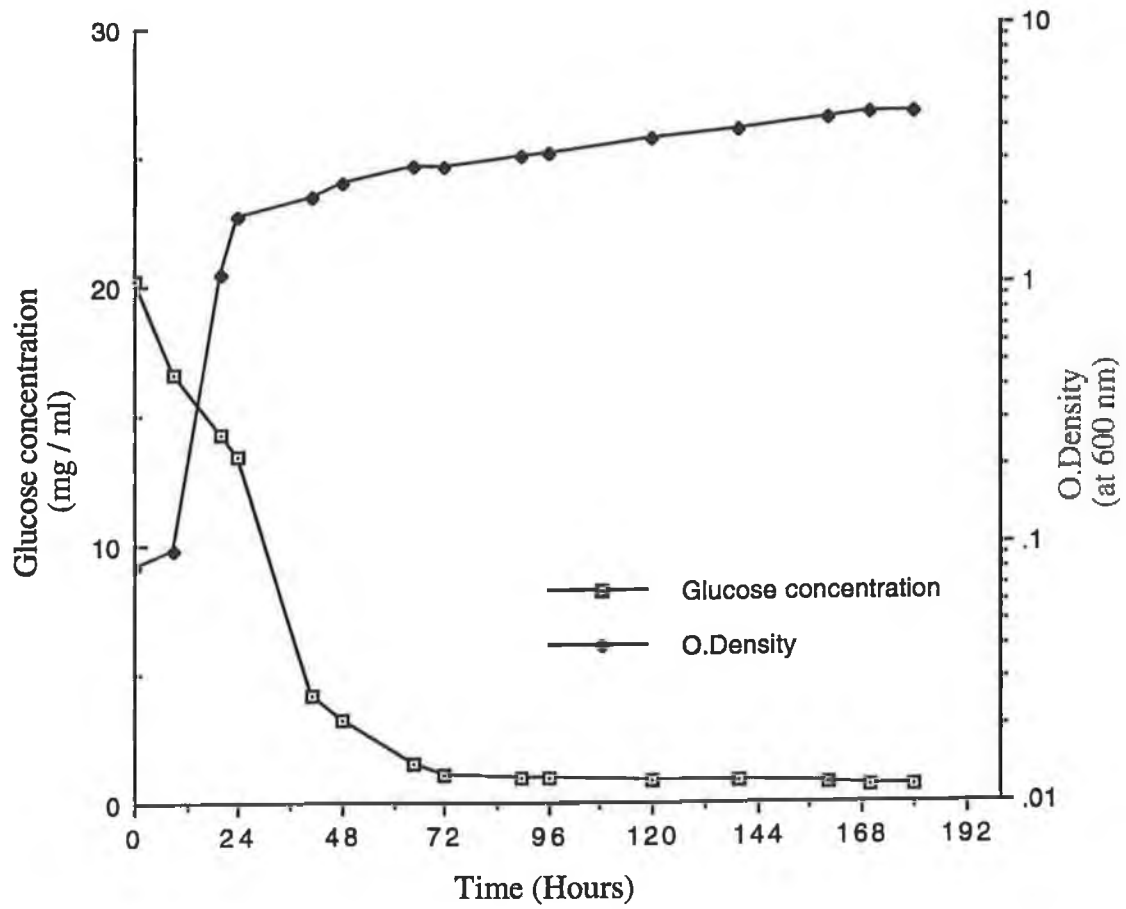

Figure 4.8.2.7 Growth and substrate consumption by the parent strain (NCYC 874) of *Phaffia rhodozyma* grown in a 2L fermenter



Looking at the consumption of glucose in terms of the percentage of the carbon source remaining in the growth medium (see Figure 4.8.2.8) the pattern of glucose consumption becomes clear.

During the first 24 hours of growth, 66.15% of the carbon source remains in the medium. Over the next 24 hours, there is a sharp decrease of 50% in the percentage glucose remaining available to the cells. After 72 hours of growth, 5.03% of the carbon source remains. Biomass and pigment production by the cells is increasing at this time, and the carbon source is being utilised during this time. After 72 hours, glucose usage remains steady, with just 1.87% glucose being consumed during the next 108 hours of growth. Pigment and biomass yields produced by the cells, now in the stationary phase of growth, have begun to level off, with production remaining steady at this time.

Glucose consumption by the mutant strain was also investigated. Glucose consumption by the mutant strain is shown in Figure 4.8.2.4.

Glucose consumption by the mutant strain is very rapid, and the mutant consumes more of the carbon source than the parent strain. As pigment and biomass yields produced by the mutant strain are greater than those produced by the parent strain, this is to be expected. Glucose consumption is rapid during the first 24 hours of growth, and 10.13 mg/ml glucose is consumed during this time. As biomass and pigment production increases, glucose consumption also increases. After 72 hours, 19.141 mg/ml of glucose has been consumed by the cells. This follows the pattern observed for the parent strain. Looking at the results presented in terms of the percentage of the carbon source remaining in the growth medium, the pattern of usage becomes clear (Figure 4.8.2.8).

During the first 24 hours of growth, 49.67% of the carbon source remains in the medium. Biomass (Figure 4.8.2.9) and pigment production (Figure 4.8.2.10) by the mutant strain increases rapidly after this time, when cells enter the exponential phase of growth. During the first 96 hours of growth 46.42% of the carbon source is consumed, and is used by the cells to produce pigment and biomass. Once biomass and pigment production remains steady, after 120 hours, glucose consumption is not as rapid. The same pattern can be observed for cell growth (Figure 4.8.2.11).

Figure 4.8.2.8 Percentage of glucose remaining in the growth medium during growth of the parent strain (NCYC 874) and a mutant strain (NRRL-Y-18734) of *Phaffia rhodozyma* in a 2L fermenter

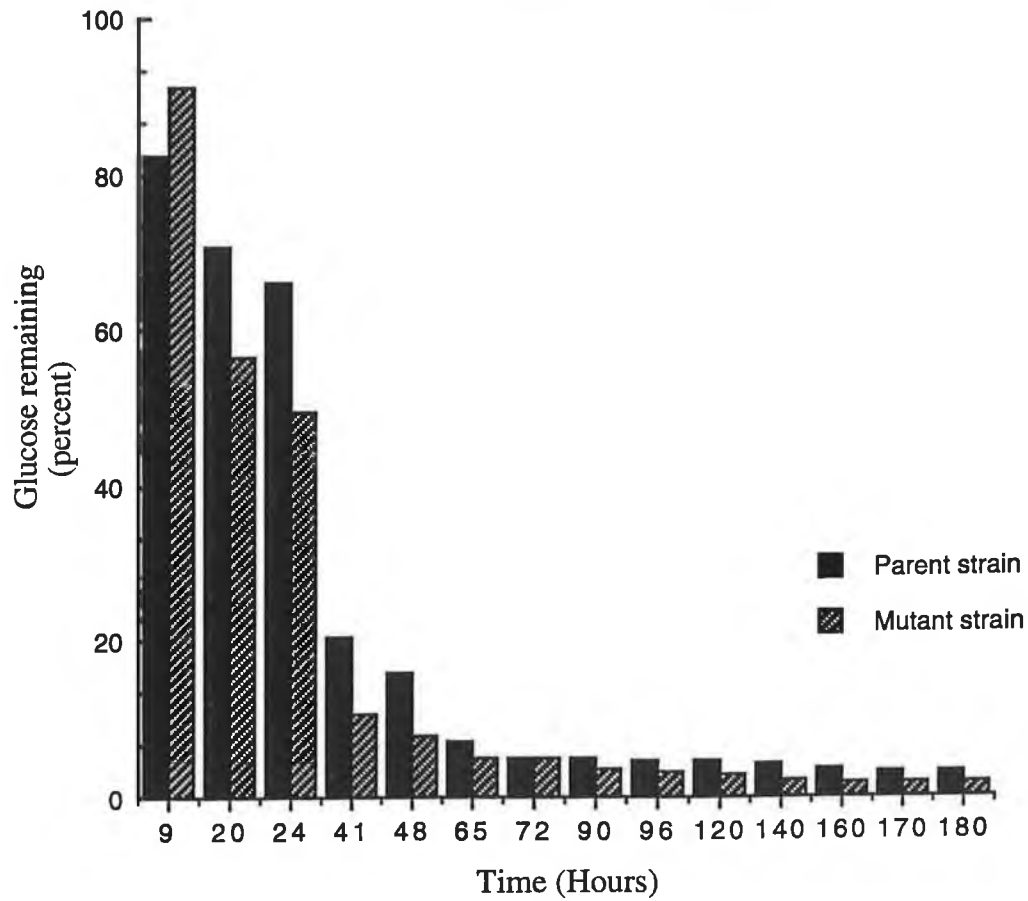

Figure 4.8.2.9 Biomass production and glucose consumption by the mutant strain (NRRL-Y-18734) of *Phaffia rhodozyma* grown in a 2L fermenter

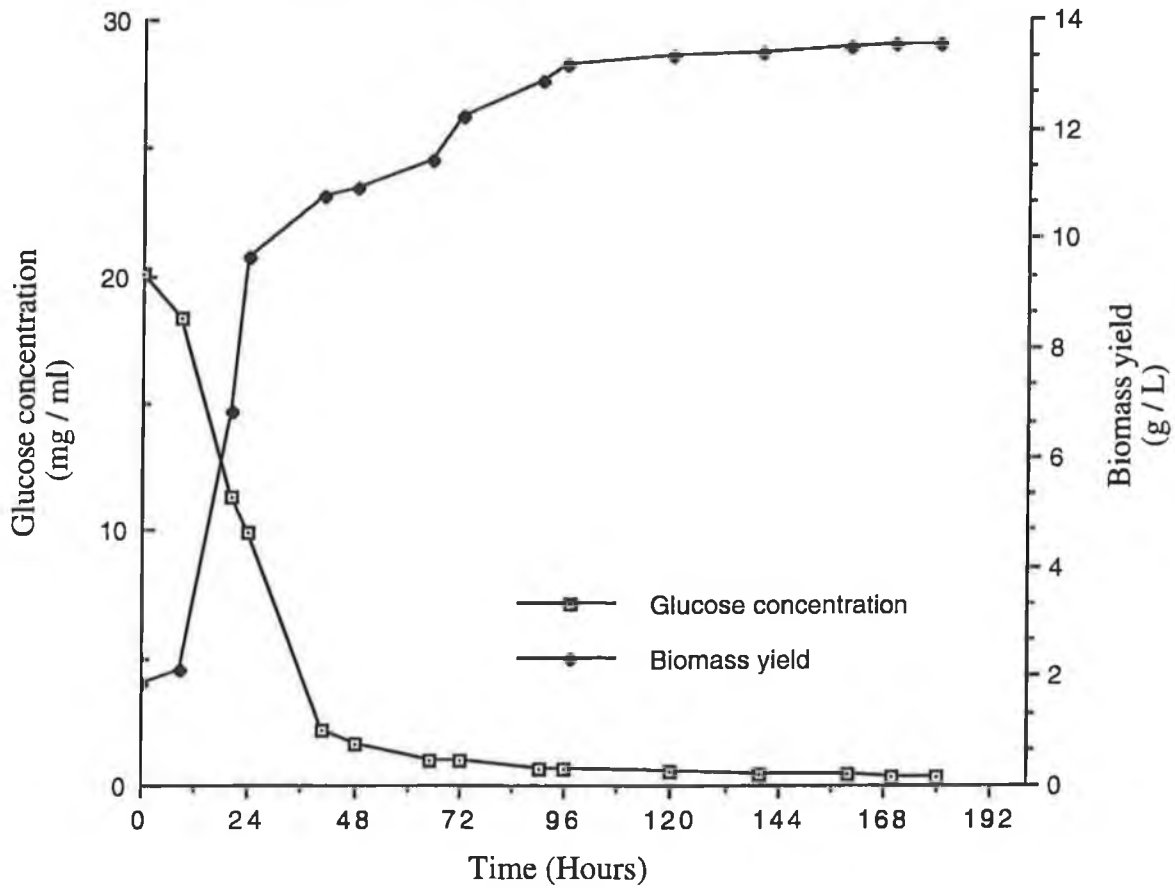

Figure 4.8.2.10 Pigment production and glucose consumption by the mutant strain (NRRL-Y-18734) of *Phaffia rhodozyma* grown in a 2L fermenter

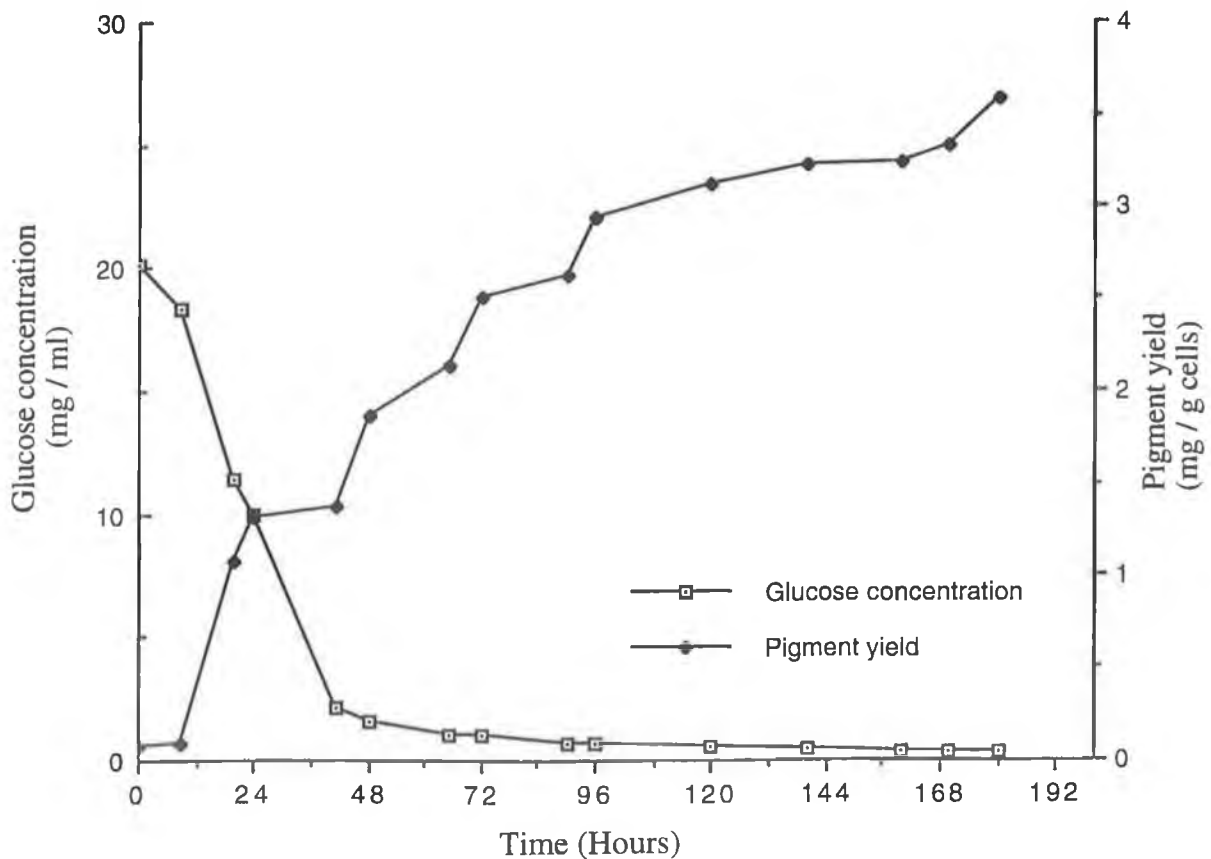
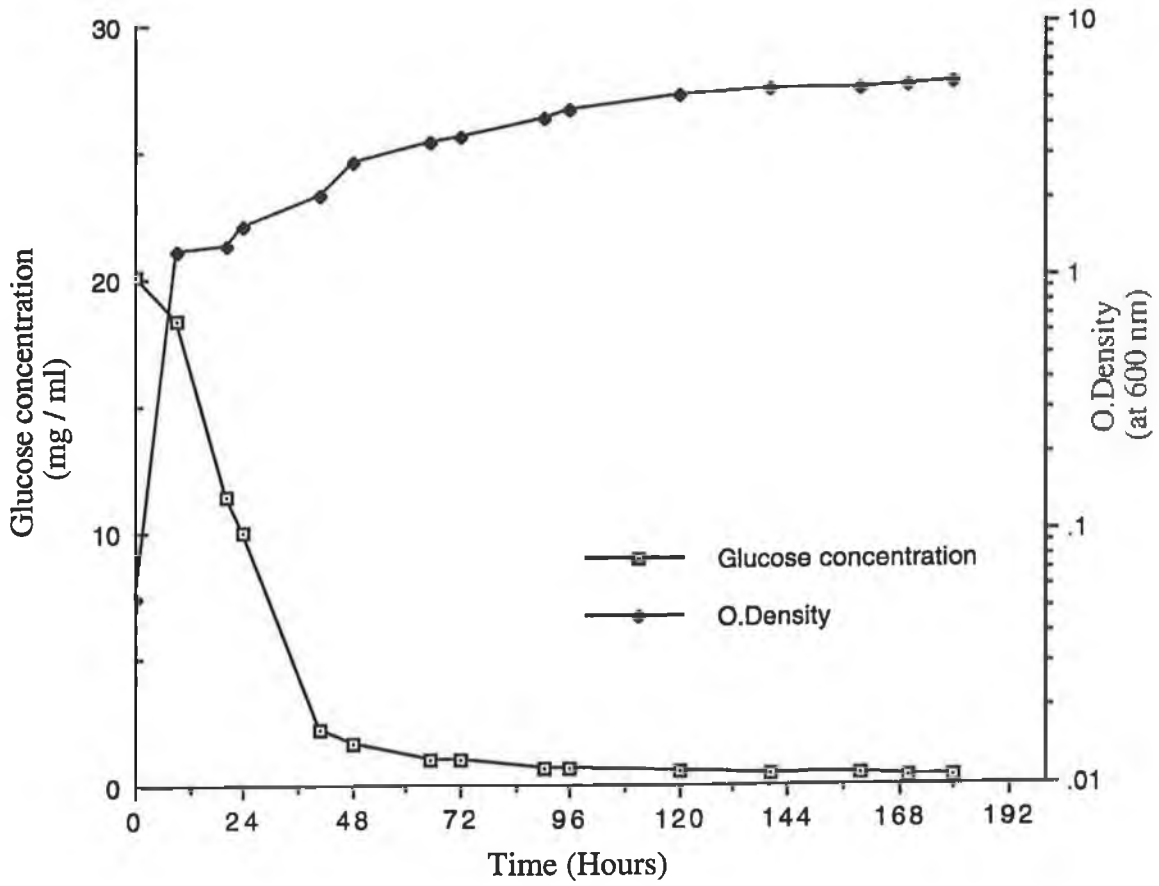

Figure 4.8.2.11 Growth and substrate consumption by the mutant strain (NRRL-Y-18734) of *Phaffia rhodozyma* grown in a 2L fermenter



As cell numbers increase, glucose consumption increases. Once cells enter the stationary phase, glucose consumption remains steady.

Consumption of the nitrogen source by the parent strain cultured in a fermenter was also investigated, and the results are shown in Figure 4.8.2.12 .

There is a steady increase in nitrogen consumption by the cells during 180 hours of growth. During the first 24 hours, 177.45 mg/l of nitrogen is consumed by the cells. During the next 24 hours, 140.43 mg/l nitrogen is consumed. Consumption of nitrogen decreases every 24 hours, up to 180 hours, even though biomass (Figure 4.8.2.13) and pigment production (Figure 4.8.2.14) increases between 24 and 96 hours. The same pattern can be observed for cell growth (Figure 4.8.2.15). Nitrogen consumption by the parent strain grown in the fermenter follows a different pattern to that observed when the strain is grown in shake flask culture (Figure 4.8.2.12). The results for nitrogen consumption by the parent strain cultivated in fermenter culture are shown in Figure 4.8.2.16, as percentage of the nitrogen remaining in the growth medium.

Consumption of the nitrogen source by the parent strain of *Phaffia rhodozyma* follows a different pattern to that observed for the carbon source. Usage of the carbon source is more rapid , and less than 3.16% of the carbon source remains after 180 hours. During the first 24 hours of growth, 83.01% of the nitrogen source remains. 18.47% of the nitrogen source is consumed during the next 48 hours. Consumption of nitrogen falls to 9.51% from 48 to 72 hours of growth, and falls to 6.96% over the next 48 hours. During the last 84 hours of growth, just 11.61% of nitrogen is consumed by the cells, an average of 3.32% every 24 hours. These results indicate that less nitrogen is consumed by the parent strain when grown in the fermenter. However, this does not result in a decrease in cell numbers (Figure 4.8.2.15), or biomass (Figure 4.8.2.13) and pigment production (Figure 4.8.2.14).by the parent strain. The results for nitrogen consumption by the parent strain are presented graphically in Figure 4.8.2.12 .

Nitrogen consumption by the mutant strain cultured in the fermenter, was also investigated. The results for nitrogen consumption are shown in Figure 4.8.2.12.

Figure 4.8.2.12 Consumption of nitrogen by the parent strain (NCYC 874) and a mutant strain (NRRL-Y-18734) of *Phaffia rhodozyma* grown in a 2L fermenter

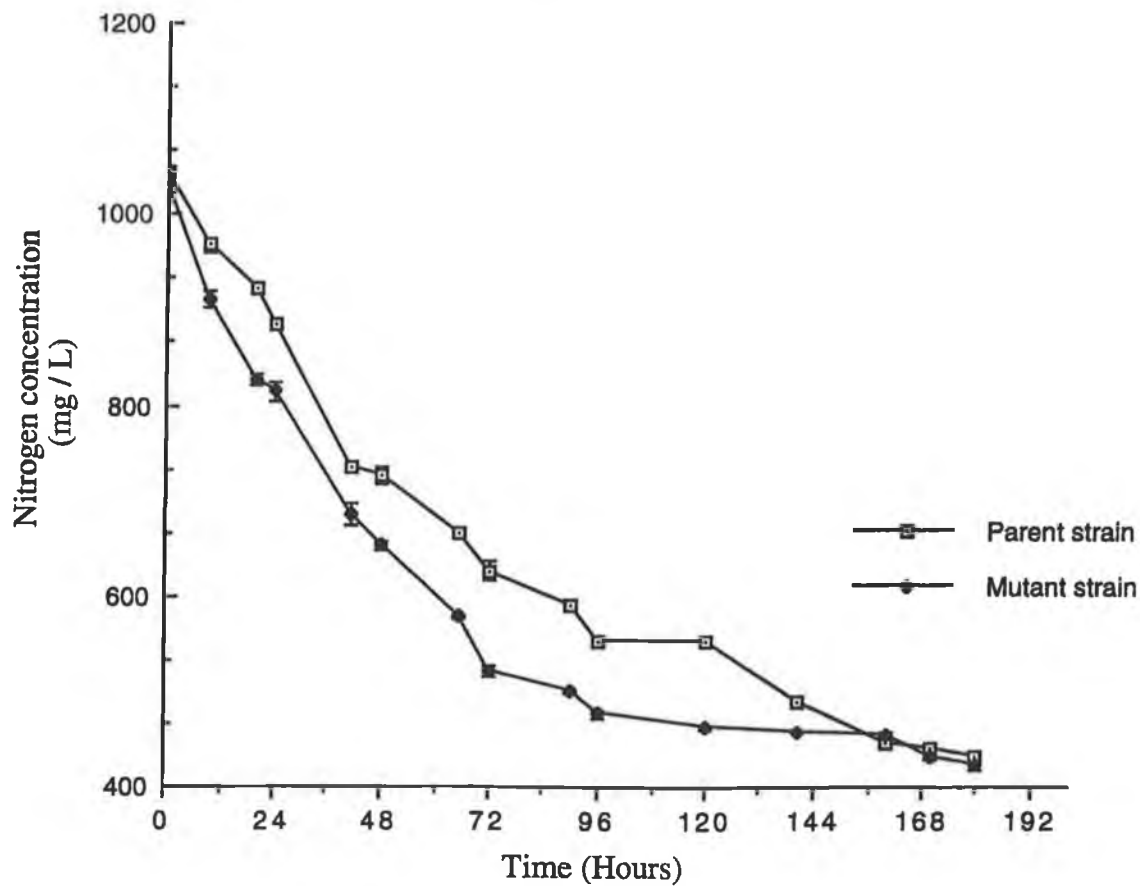

Figure 4.8.2.13 Biomass production and nitrogen consumption by the parent strain (NCYC 874) of *Phaffia rhodozyma* grown in a 2L fermenter

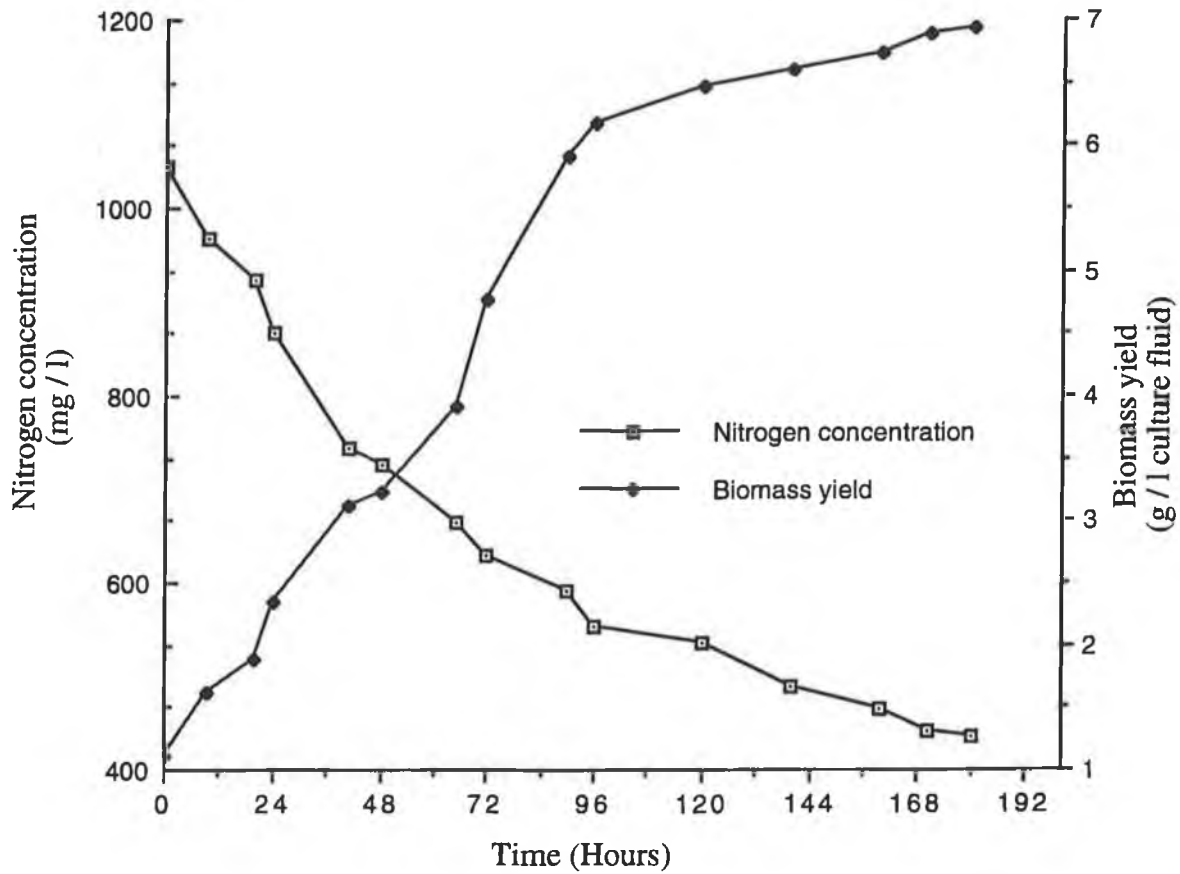

Figure 4.8.2.14 Astaxanthin production and nitrogen consumption by the parent strain (NCYC 874) of *Phaffia rhodozyma* grown in a 2L fermenter

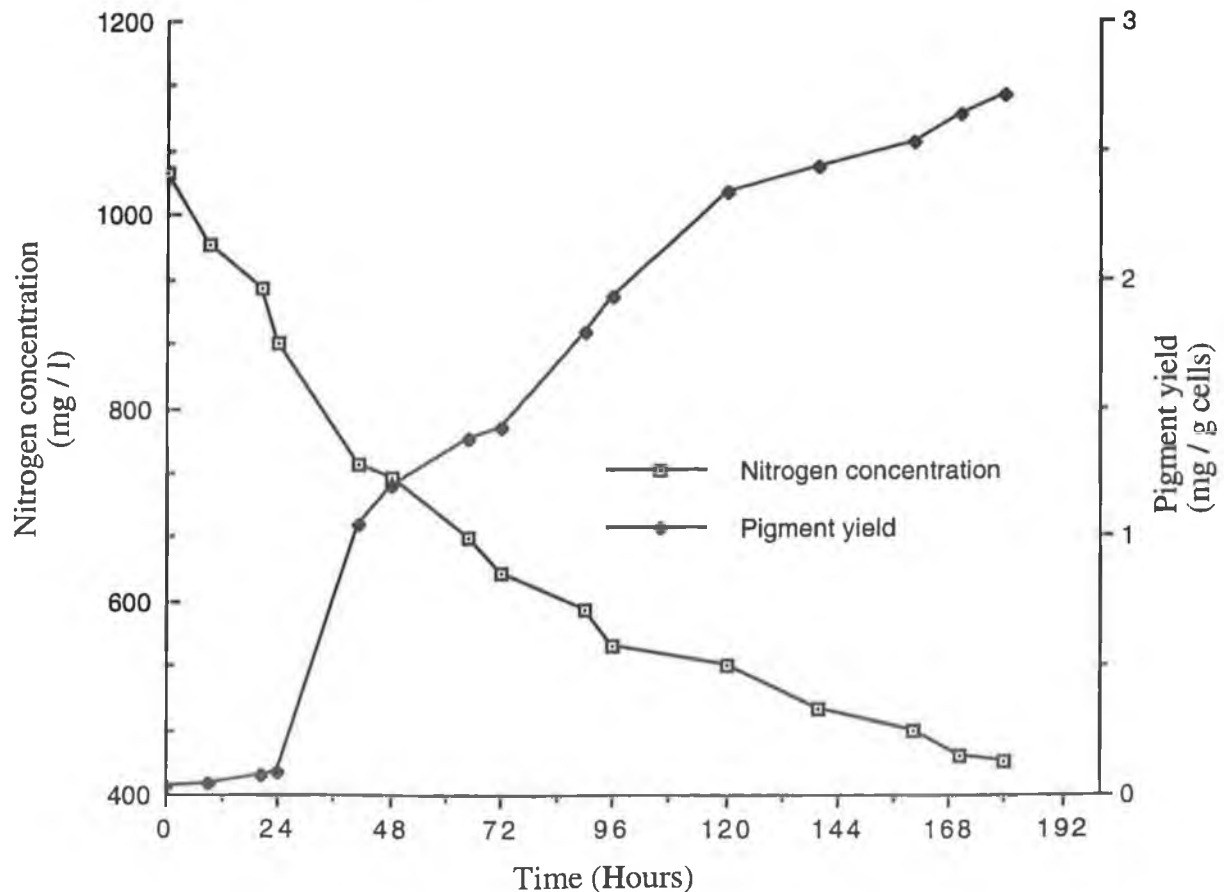
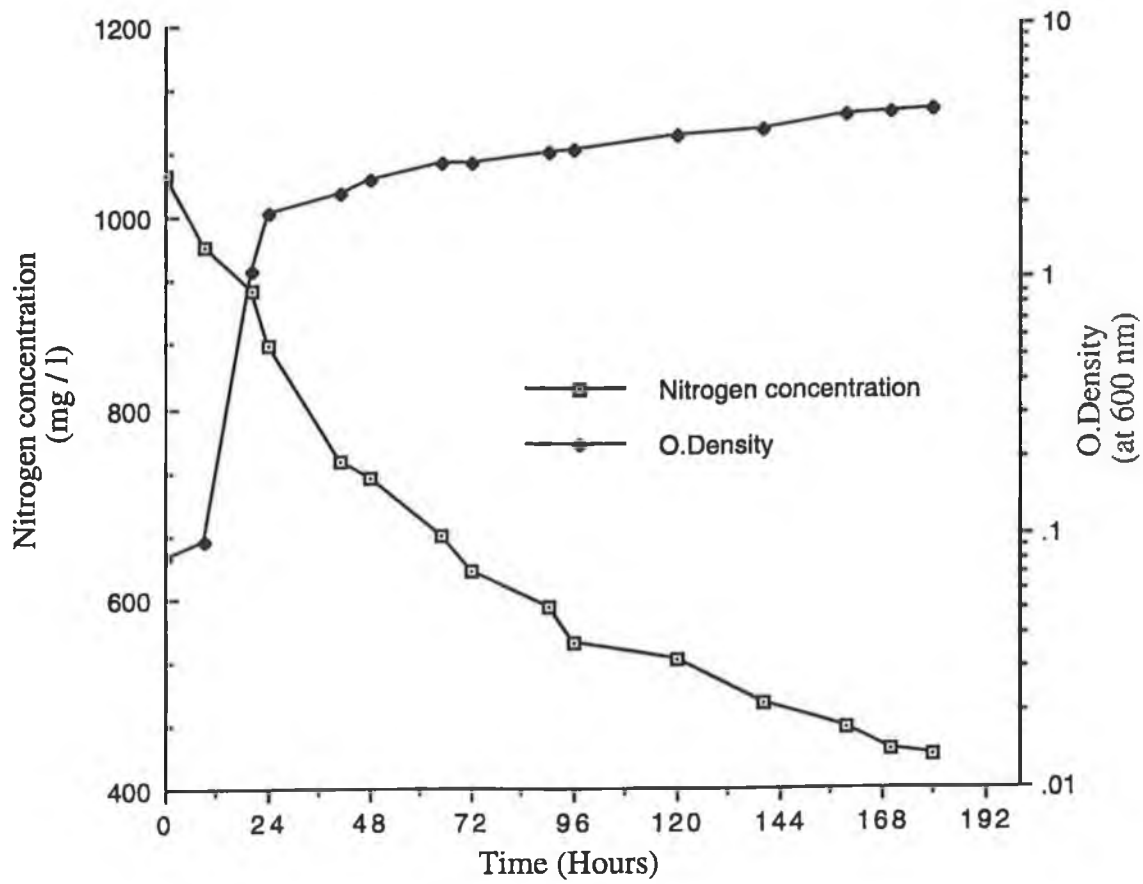

Figure 4.8.2.15 Growth and nitrogen consumption by the parent strain (NCYC 874) of *Phaffia rhodozyma* grown in a 2L fermenter



As observed previously with the parent strain, there is a steady increase in nitrogen consumption by the mutant strain over 180 hours. The mutant consumes more nitrogen than the parent strain, with 10.93 mg/l less of the nitrogen source remaining available to the mutant strain after 180 hours. As observed with the parent strain nitrogen consumption occurs as pigment and biomass are produced by the yeast. The results are presented in terms of the percentage of the nitrogen source remaining in the growth medium in Figure 4.8.2.16.

Consumption of the nitrogen source by the mutant strain follows a different pattern to that observed for the carbon source. Consumption of the carbon source is more rapid, with 1.60% carbon remaining after 180 hours. After 180 hours of growth 40.88% of the nitrogen source remains. As biomass (Figure 4.8.2.17) and pigment (Figure 4.8.2.18) production increases nitrogen is consumed, and after 120 hours 44.85% remains in the growth medium. As cells enter the stationary phase of growth which occurs at 120 hours, nitrogen consumption begins to slow down, and just 3.95% of the nitrogen source is consumed by the cells during the last 60 hours of culturing. The same pattern can be observed for cell growth and nitrogen consumption (Figure 4.8.2.19). As cell growth occurs exponentially, nitrogen consumption increases. Once cells enter the stationary phase of growth, nitrogen consumption remains steady.

The results obtained in this section, indicate that biomass and pigment production, and nitrogen and glucose consumption by the parent strain of *Phaffia rhodozyma* cultured in a 2l fermenter, follows a different pattern to that observed when the parent strain was grown in shake flask culture. Biomass production by the parent strain decreased after 120 hours of growth, when the parent strain was grown in shake flask culture (Figure 4.6.2.1) as did pigment production (Figure 4.6.2.2). This could be due to oxygen levels falling in the growth medium, which would affect biomass and pigment production. When the parent strain was cultured in the fermenter, biomass and pigment production increased during 180 hours of culturing. Biomass and pigment production by *Phaffia rhodozyma* has been shown to increase once the cells enter the exponential phase of growth, and remain steady once cells enter the stationary phase. This was observed when the parent strain of *Phaffia rhodozyma* was grown in both the shake flask and fermenter cultures.

Figure 4.8.2.16 Percentage nitrogen remaining in the growth medium during growth of the parent strain (NCYC 874) and a mutant strain (NRRL-Y-18734) of *Phaffia rhodozyma* in a 2L fermenter

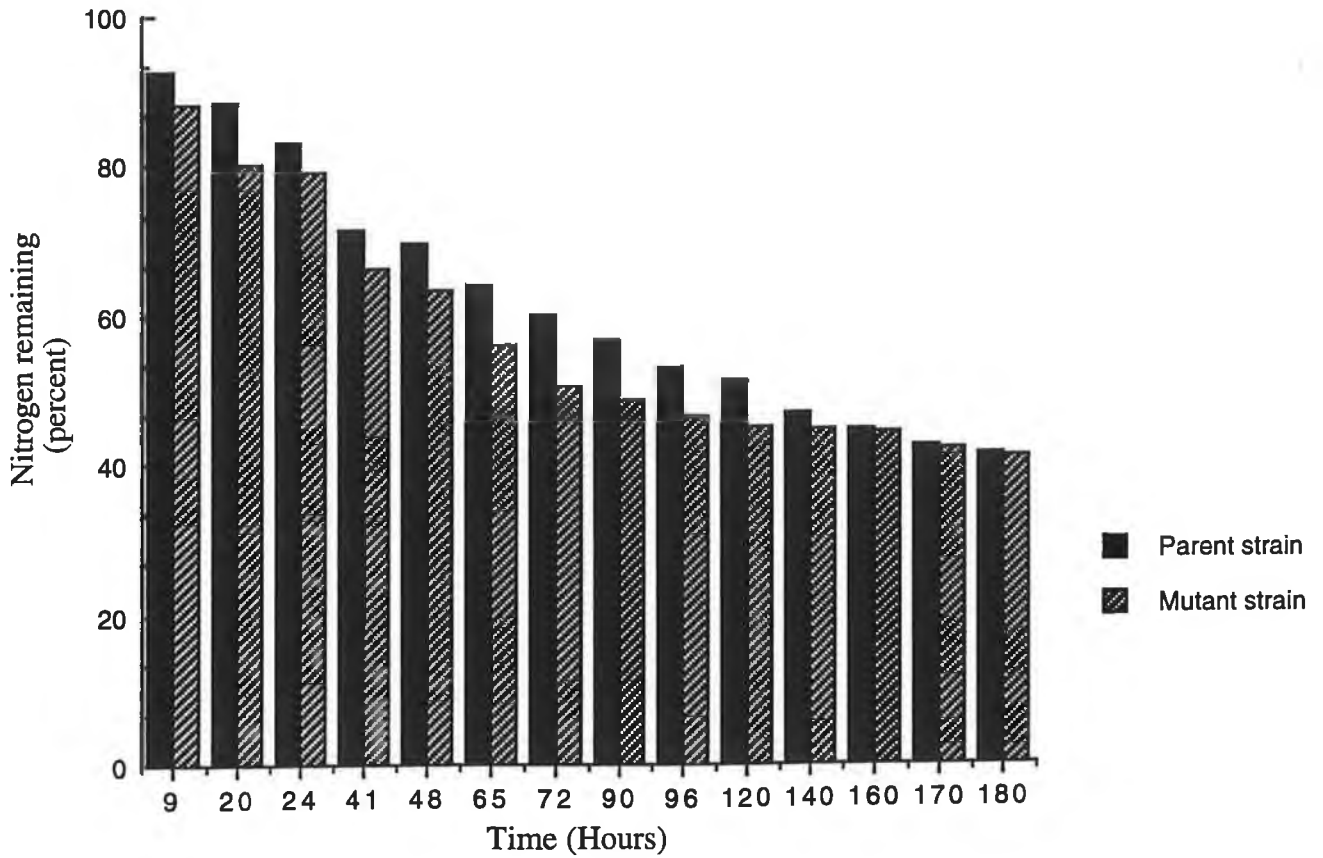

Figure 4.8.2.17 Biomass production and nitrogen consumption by a mutant strain (NRRL-Y-18734) of *Phaffia rhodozyma* grown in a 2L fermenter

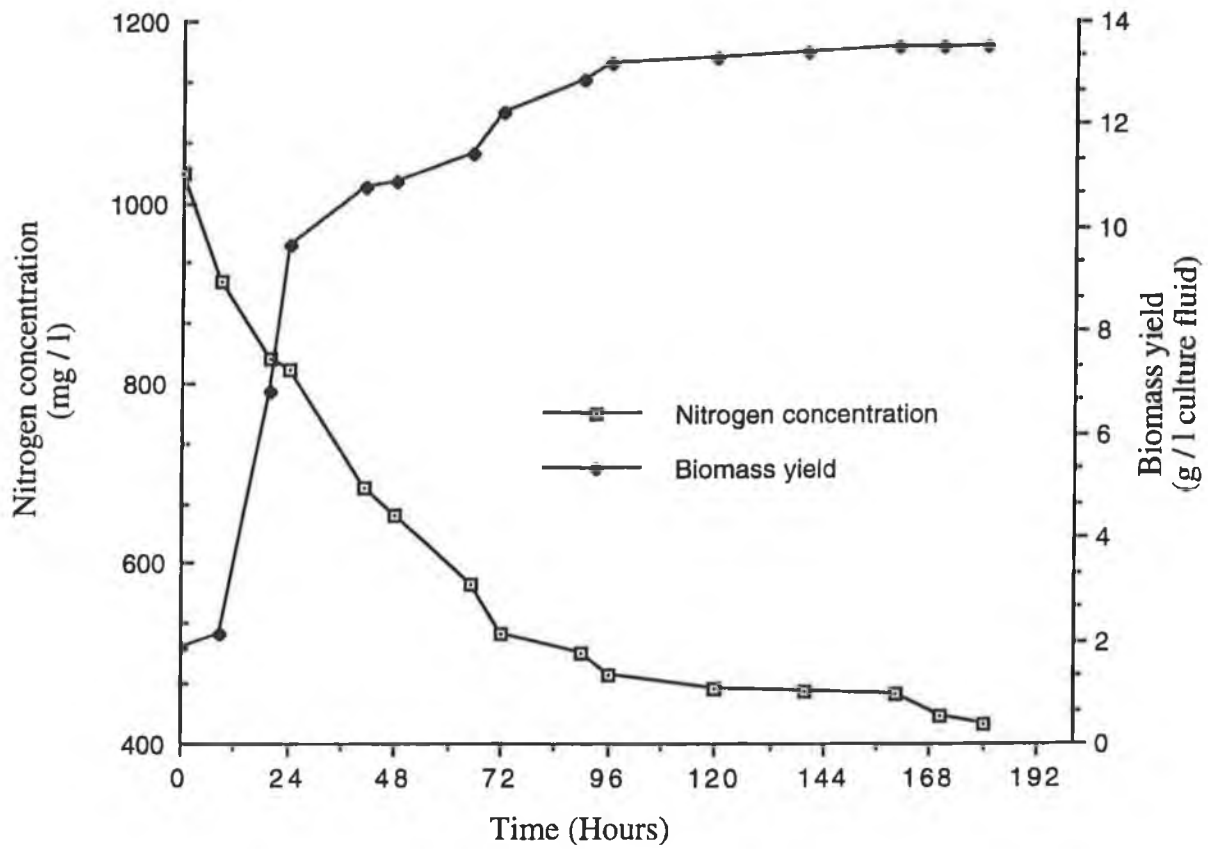

Figure 4.8.2.18 Astaxanthin production and nitrogen consumption by a mutant strain (NRRL-Y-18734) of *Phaffia rhodozyma* grown in a 2L fermenter

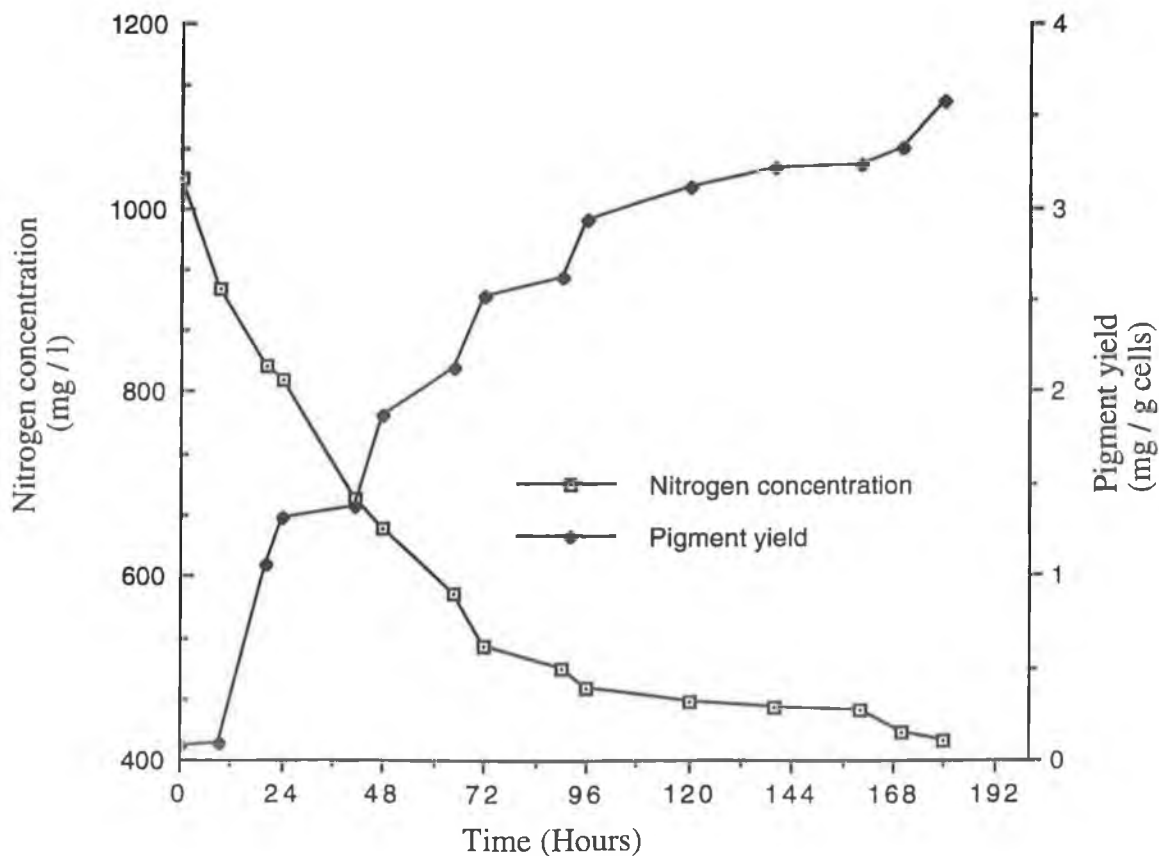
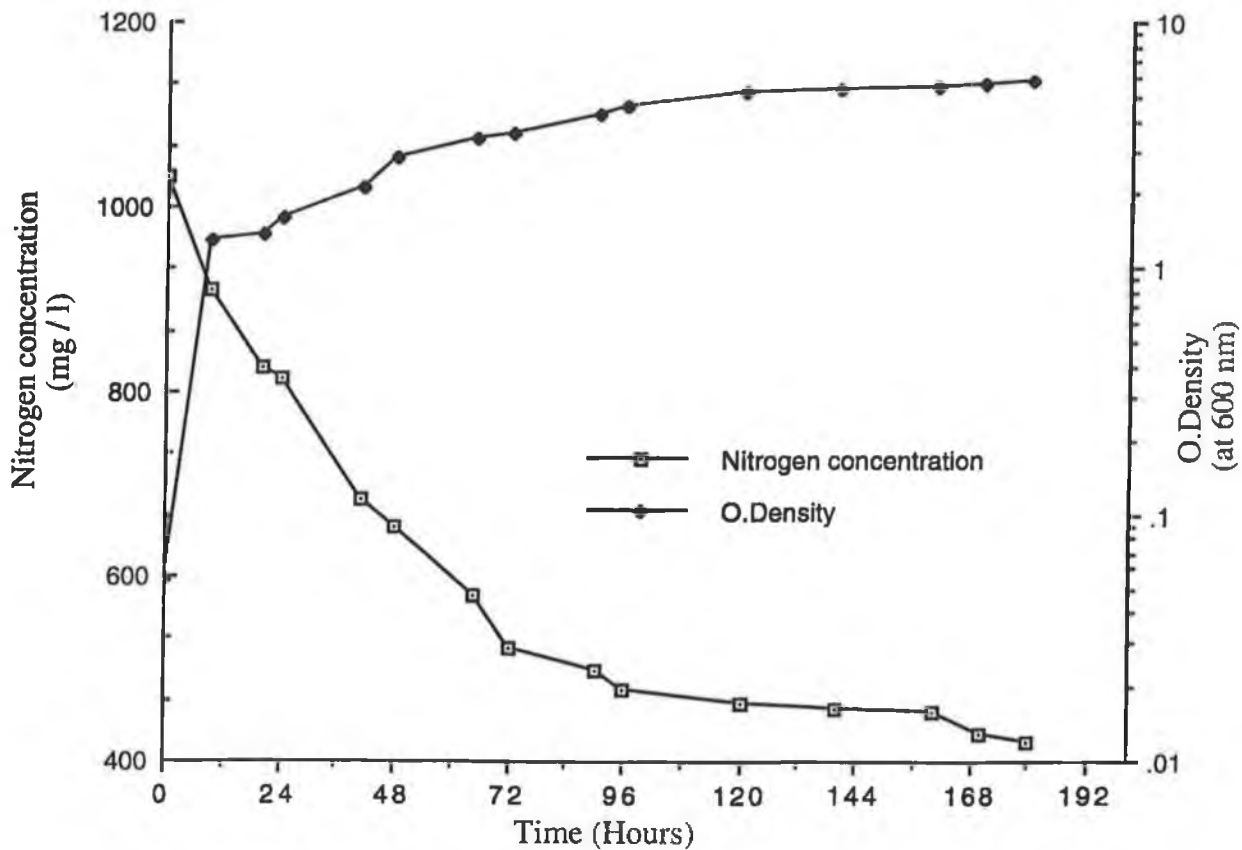

Figure 4.8.2.19 Growth and nitrogen consumption by a mutant strain (NRRL-Y-18734) of *Phaffia rhodozyma* grown in a 2L fermenter



Cell growth, as measured by optical density, followed the same pattern, irrespective of whether the parent strain was grown in shake flask or fermenter culture, and this observation can also be made with regard to consumption of the carbon source. Less of the nitrogen source is consumed by the parent strain, when grown in the fermenter. Consumption of the nitrogen source has been shown to have an effect on pigment and biomass production by the parent strain when grown in shake flask culture (Section 4.6). However, this does not seem to affect biomass and pigment production, or the growth of the yeast, when grown in the fermenter.

Statistical analysis was carried out on the data generated in this section of research to determine the extent of correlation, if any, between the various parameters.

Table 4.8.2.3 Coefficients of correlation calculated for biomass production and pigment production by the parent and a mutant strain of *Phaffia rhodozyma* grown in a 2l fermenter

Strain used	Coefficient of Correlation (r)	T - statistic (t)	Accept/reject null hypothesis (r = 0)
Parent strain (NCYC 874)	0.977904	16.87	Reject
Mutant strain (NRRL-Y-18734)	0.939467	9.89	Reject

The t-value obtained from the t-table for a sample size of 15, minus two, (n-2) at the 95% confidence level, was 1.771 . Where the t-statistic exceeds this value, the null hypothesis of no correlation is rejected, therefore the correlation coefficient obtained is accepted as being statistically significant. Where the t-statistic does not exceed 1.771, then the null hypothesis is accepted, and the correlation coefficient is not accepted s being statistically significant.

The results shown in Table 4.8.2.3 indicate that strong positive correlation exists between biomass and pigment production by the parent and mutant strain of *Phaffia rhodozyma*. Both correlation coefficients are statistically significant at the 95% confidence level, therefore the null hypothesis is rejected. Positive correlation implies that large values of x (biomass) are associated with large

values of y (pigment), and vice versa. As observed previously for the parent and mutant strain, as pigment yields increased, so too did biomass yields. This finding is borne out by the strong positive correlation existing between biomass and pigment production by *Phaffia rhodozyma*. It must be noted that stronger correlation exists between biomass and pigment production by the parent strain, and this is the opposite to that observed when the yeast was grown in shake flask culture (Figure 4.6.2.1).

Table 4.8.2.4 Coefficients of correlation calculated for growth and pigment production by the parent and a mutant strain of *Phaffia rhodozyma* grown in a 2l fermenter

Strain used	Coefficient of Correlation (r)	T - statistic (t)	Accept/reject null hypothesis (r = 0)
Parent strain (NCYC 874)	0.960463	12.44	Reject
Mutant strain (NRRL-Y-18734)	0.976938	16.50	Reject

The results shown above indicate that strong positive correlation exists between cell growth and pigment production by *Phaffia rhodozyma*. As pigment yields increase, so too does growth. The result obtained for the mutant strain is more statistically significant, and indicates that a stronger relationship between growth and pigment production exists for the mutant strain. This finding also agrees with the result obtained for the shake flask cultivation of the yeast (Table 4.6.2.2).

The results shown in Table 4.8.2.5 indicate that strong positive correlation exists between biomass production and growth of *Phaffia rhodozyma*. As biomass production increases, so does cell growth. As observed previously with the correlation between growth and pigment production, stronger correlation exists between cell growth and biomass production by the parent strain. Both results are statistically significant at the 95% confidence level.

Table 4.8.2.5 Coefficients of correlation calculated for growth and biomass production by the parent and a mutant strain of *Phaffia rhodozyma* grown in a 2l fermenter

Strain used	Coefficient of Correlation (r)	T - statistic (t)	Accept/reject null hypothesis (r = 0)
Parent strain (NCYC 874)	0.954903	11.60	Reject
Mutant strain (NRRL-Y-18734)	0.877959	6.61	Reject

Table 4.8.2.6 Coefficients of correlation calculated for glucose consumption and astaxanthin production by the parent and a mutant strain of *Phaffia rhodozyma* grown in a 2l fermenter

Strain used	Coefficient of Correlation (r)	T - statistic (t)	Accept/reject null hypothesis (r = 0)
Parent strain (NCYC 874)	- 0.88810	- 6.99	Reject
Mutant strain (NRRL-Y-18734)	- 0.89374	- 7.18	Reject

The results shown in Table 4.8.2.6 indicate that strong negative correlation exists between glucose usage and pigment production by *Phaffia rhodozyma*. Negative correlation implies that large values of y (pigment) are associated with small values of x (glucose). As glucose is consumed by the cells, pigment production increases. Negative correlation reflects this. The result is more statistically significant for the mutant strain, and indicates that the relationship between pigment production and glucose usage is stronger for the mutant strain than for the parent strain. This also agrees with the previous correlation results obtained for these two parameters, when the yeast was grown in shake flask culture (Table 4.6.2.4).

Table 4.8.2.7 Coefficients of correlation calculated for glucose consumption and biomass production by the parent and a mutant strain of *Phaffia rhodozyma* grown in a 2l fermenter

Strain used	Coefficient of Correlation (r)	T - statistic (t)	Accept/reject null hypothesis (r = 0)
Parent strain (NCYC 874)	- 0.87268	- 6.44	Reject
Mutant strain (NRRL-Y-18734)	- 0.97368	- 15.40	Reject

The results shown above indicate a strong negative correlation between glucose usage and biomass production by *Phaffia rhodozyma*. As glucose is consumed by the yeast, biomass levels increase. The result is more significant for the mutant strain, indicating a stronger relationship between biomass production and glucose consumption, than for the parent strain.

Table 4.8.2.8 Coefficients of correlation calculated for growth (as measured by optical density) and glucose consumption by the parent and a mutant strain of *Phaffia rhodozyma* grown in a 2l fermenter

Strain used	Coefficient of Correlation (r)	T - statistic (t)	Accept/reject null hypothesis (r = 0)
Parent strain (NCYC 874)	- 0.90810	- 7.82	Reject
Mutant strain (NRRL-Y-18734)	- 0.84006	- 5.58	Reject

The results indicate a strong negative correlation exists between glucose consumption and growth of *Phaffia rhodozyma*. As glucose is consumed by the cells, numbers increase. The result is more significant for the parent strain, and this differs from the finding obtained when the yeast was grown in shake flask culture (Table 4.6.2.6). This indicates that the relationship between glucose consumption and cell growth is stronger for the parent strain when grown in shake flask culture, and is stronger for the mutant strain when grown in the fermenter.

Table 4.8.2.9 Coefficients of correlation calculated for astaxanthin production and nitrogen consumption by the parent and a mutant strain of *Phaffia rhodozyma* grown in a 2l fermenter

Strain used	Coefficient of Correlation (r)	T - statistic (t)	Accept/reject null hypothesis (r = 0)
Parent strain (NCYC 874)	- 0.97208	- 14.94	Reject
Mutant strain (NRRL-Y-18734)	- 0.97876	- 17.21	Reject

Strong negative correlation exists between nitrogen consumption and pigment production by *Phaffia rhodozyma*. As observed previously for glucose consumption and pigment production (Table 4.8.2.6), stronger negative correlation exists between nitrogen consumption and pigment production by the mutant strain. This agrees with the result obtained when the yeast was grown in shake flask culture (Table 4.6.2.7). Both results are statistically significant at the 95% confidence level. This result would indicate that the mutant strain utilises nitrogen for pigment production, more than the parent strain.

Table 4.8.2.10 Coefficients of correlation calculated for nitrogen consumption and biomass production by the parent and a mutant strain of *Phaffia rhodozyma* grown in a 2l fermenter

Strain used	Coefficient of Correlation (r)	T - statistic (t)	Accept/reject null hypothesis (r = 0)
Parent strain (NCYC 874)	- 0.94968	- 10.93	Reject
Mutant strain (NRRL-Y-18734)	- 0.98029	- 17.89	Reject

The results indicate that strong negative correlation exists between biomass production and nitrogen usage by *Phaffia rhodozyma*. The result is more statistically significant for the mutant strain, indicating that the relationship between biomass production and nitrogen is stronger for the mutant strain, than the parent strain. This result indicates that the mutant strain is more efficient at

utilising nitrogen for biomass production, then the parent strain. This also agrees with the result obtained when the yeast was grown in shake flask culture (Table 4.6.2.8).

Table 4.8.2.11 Coefficients of correlation calculated for growth (as measured by optical density) and nitrogen consumption by the parent and a mutant strain of *Phaffia rhodozyma* grown in a 2l fermenter

Strain used	Coefficient of Correlation (r)	T - statistic (t)	Accept/reject null hypothesis (r = 0)
Parent strain (NCYC 874)	- 0.96029	- 12.41	Reject
Mutant strain (NRRL-Y-18734)	- 0.98614	- 21.43	Reject

Strong negative correlation is observed to exist between growth of *Phaffia rhodozyma* and consumption of nitrogen. As observed previously with nitrogen usage and biomass production, stronger correlation exists between nitrogen usage by the mutant strain and cell growth. Both results are statistically significant at the 95% level.

Table 4.8.2.12 Coefficients of correlation calculated for glucose consumption and nitrogen consumption by the parent and a mutant strain of *Phaffia rhodozyma* grown in a 2l fermenter

Strain used	Coefficient of Correlation (r)	T - statistic (t)	Accept/reject null hypothesis (r = 0)
Parent strain (NCYC 874)	0.930314	9.15	Reject
Mutant strain (NRRL-Y-18734)	0.939043	9.85	Reject

Strong positive correlation is shown to exist between nitrogen and glucose consumption by *Phaffia rhodozyma*. As biomass and pigment yields produced by the cells increases, glucose and nitrogen are depleted. The correlation obtained for the mutant strain is more significant. This indicates that there is a

close relationship between biomass and pigment production by the parent and mutant strain, and glucose and nitrogen consumption. The mutant strain consumes more nitrogen and glucose than the parent strain, therefore stronger correlation between glucose and nitrogen usage for the mutant strain is to be expected.

4.8.3 HPLC Analysis of *Phaffia rhodozyma* Carotenoids

Qualitative analysis of astaxanthin was carried out as fully described in Chapter Three. Reverse phase HPLC allows good separation of the individual components of *Phaffia rhodozyma* extracts that absorb at 470 nm.

To ensure purity of the carotenoid standard used in this analysis, several standards were prepared using pure crystalline astaxanthin and β -carotene (Roche Vitamins and Chemicals, U.K.), and were run through the HPLC under conditions fully described in Chapter Three. A chromatogram obtained for the crystalline astaxanthin standard is shown in Figure 4.8.3.1 . The retention time pure *trans* - astaxanthin was determined to be 5.24 minutes. Pure crystalline β -carotene was also used to prepared standards, which were then run through the HPLC. A chromatogram obtained for the β -carotene standard is shown in Figure 4.8.3.2 . The retention time for pure β -carotene was determined to be 19.196 minutes.

There is great variation in the retention times obtained for astaxanthin using reverse phase HPLC quoted in the literature, with retention times from 2.6 to 2.7 minutes (Prevatt *et al.* 1991), to 5 minutes (de Haan *et al.* 1991) being obtained. However, very little data is available for comparison.

After extraction of astaxanthin from *Phaffia rhodozyma* (NCYC 874) cells using enzyme treatment, pigments were extracted into methanol. Samples were then analysed by HPLC. A chromatogram obtained for a sample taken from the fermenter after 120 hours, is given in Figure 4.8.3.3 . Peak one had a retention time of 4.967, and was determined to be *trans* - astaxanthin. The pure standard had a retention time of 5.24 minutes. Peak four had a retention time of 18.734 minutes, and was determined to be β -carotene. The pure standard had a retention of 19.196 minutes.

Figure 4.8.3.1 HPLC chromatogram obtained for the astaxanthin standard sample

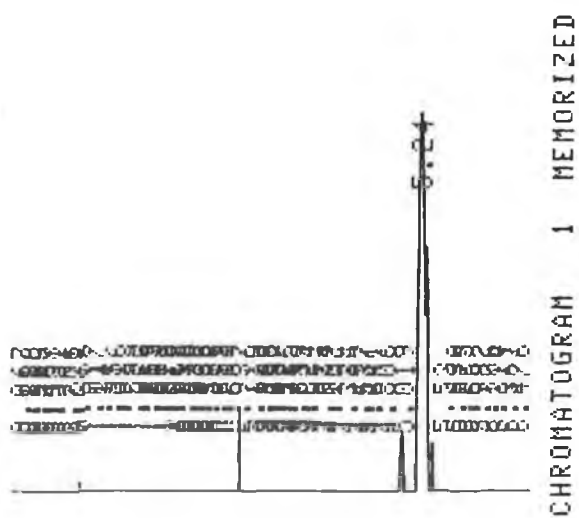

Figure 4.8.3.2 HPLC chromatogram obtained for the β -carotene standard sample

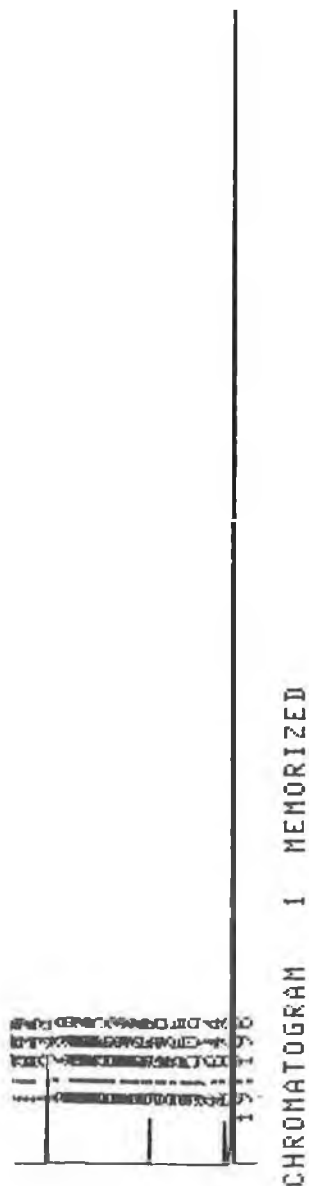
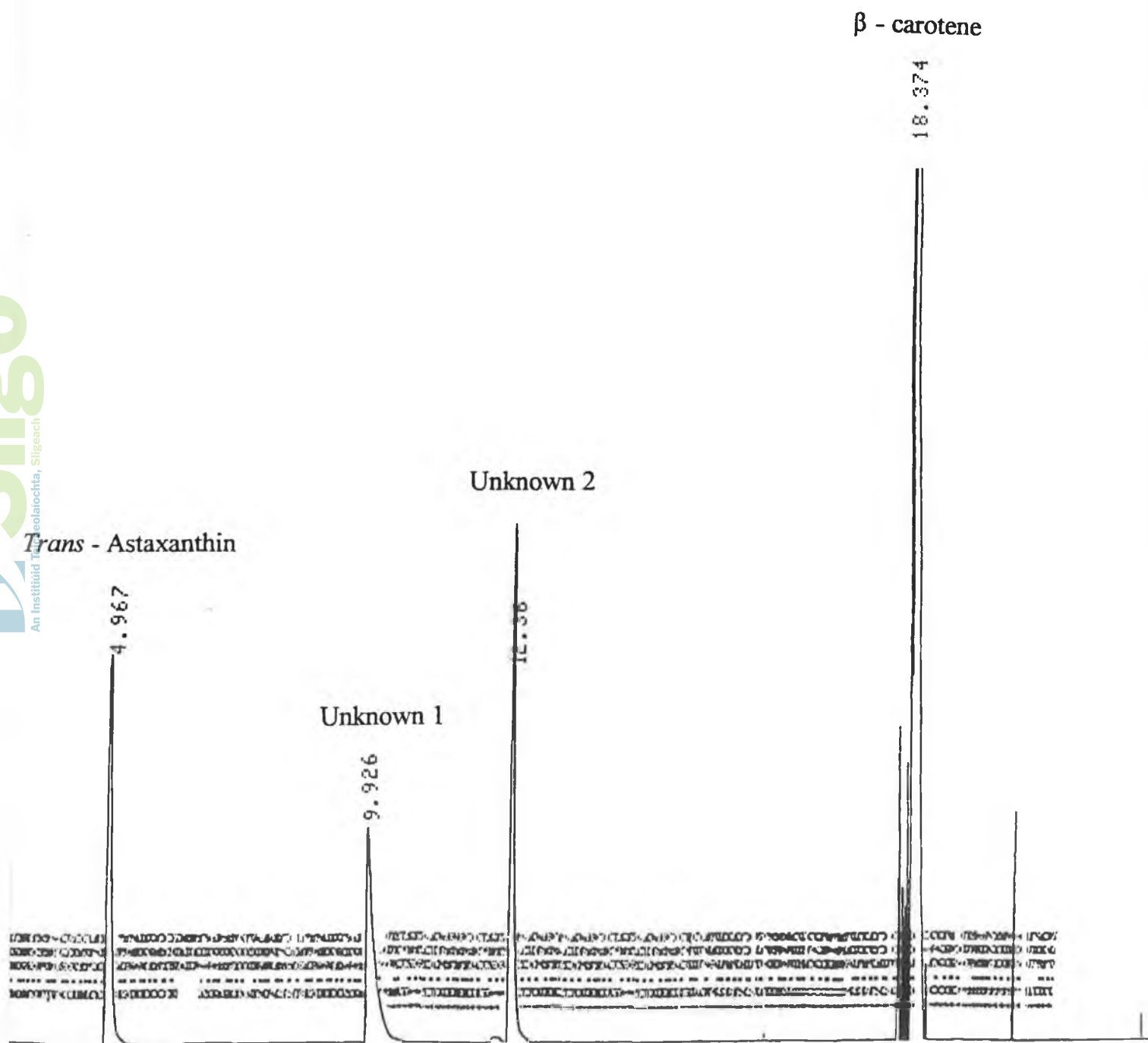

Figure 4.8.3.3 HPLC chromatogram of sample taken from the fermenter culture after 120 hours, showing separation of the individual carotenoids of *Phaffia rhodozyma*



Using normal phase HPLC, individual components of a *Phaffia rhodozyma* extract can be analysed (Prevatt *et al.* 1991). It is suggested that pigments elute in the following order; β -carotene, Echinenone, *trans* - astaxanthin and *cis* - astaxanthin. It is highly possible that the two unknown peaks one and two are echinenone and *cis* - astaxanthin. Each analysis carried out by HPLC was carried out for twenty minutes. All the individual components should have eluted after 15 minutes or so (Prevatt *et al.* 1991).

Good peak resolution was obtained using reverse phase HPLC, and two of the carotenoids in the *Phaffia rhodozyma* (NCYC 874) sample were identified.

4.8.4 TLC analysis of *Phaffia rhodozyma* carotenoids

TLC analysis was carried out using pure crystalline standards of β -carotene and *trans* - astaxanthin, obtained from Roche Vitamins and Chemicals (U.K.). A sample was run on the same plate as the two standards, to observe the separation of the individual carotenoids in the *Phaffia rhodozyma* sample.

Samples were taken from the fermenter after 120 hours, and enzyme treatment was carried out. Pigments were extracted into methanol. A sample was taken from the parent strain culture and run on the TLC plate (ps sample), together with the two standards. A sample was also taken from the mutant strain culture, and run on a separate plate (ms sample), together with the two standards. Individual carotenoids were identified on the basis of their Rf values, and co-chromatography with β -carotene and *trans* - astaxanthin.

Depending on the solvent system used, different Rf values can be obtained for the individual carotenoids in a *Phaffia rhodozyma* extract. For example, An *et al.* (1989) used a mix of 20% acetone and 80% petroleum ether, on silica plates 0.25 mm thick, and obtained the Rf values shown in Table 4.8.4.1 .

Table 4.8.4.1 Rf values for individual *Phaffia rhodozyma* carotenoids

Carotenoid	Rf Value
<i>cis</i> - astaxanthin	0.22
<i>trans</i> - astaxanthin	0.29
Phenicoxanthin	0.45
Echinenone	0.73
β -carotene	0.95

Different Rf values will be obtained for the pigment depending on the solvent system used, but the pigments should separate out in the order shown above.

The two standards were run on the same plate as the sample (ps) taken from the fermenter when the parent strain was cultured. The Rf values obtained for the individual carotenoids in the sample are given in Table 4.8.4.2 .

Table 4.8.4.2 Rf values obtained for the carotenoids in the *Phaffia rhodozyma* (parent strain) extract

Carotenoid	Rf Value	Colour
Carotenoid 1	0.19	Yellow / red
Carotenoid 2	0.50	Yellow / orange
Carotenoid 3	0.78	Yellow / red
Carotenoid 4	0.97	Orange / yellow
<i>trans</i> - astaxanthin (standard)	0.48	Orange / red
β -carotene (standard)	0.98	Yellow / orange

The Rf value obtained for the *trans* - astaxanthin standard was 0.48 . The Rf value obtained for carotenoid number 2 was 0.50 . Carotenoid 2 was determined to be *trans* - astaxanthin. The β -carotene standard had an Rf value of 0.98, while carotenoid number 4 was found to have an Rf value of 0.97, therefore, carotenoid number 4 was determined to be β -carotene. The other carotenoids were identified on the basis of the Rf values quoted in the literature. An *et al.*(1989) suggested that the individual carotenoids in *Phaffia rhodozyma* extracts separated out in the following order: *cis* - astaxanthin, *trans*

- astaxanthin, Echinenone and β -carotene. On the basis of this information, carotenoid 1 was determined to be *cis* - astaxanthin, and carotenoid 3 was determined to be Echinenone. Photographs were taken of the TLC plate on which the sample was run, but pigment colour could not be distinguished, therefore the photographs are not included here.

A sample taken from the fermenter when the mutant strain was cultured, was also run on a TLC plate together with the two standards. The Rf values obtained for the individual carotenoids in the sample are given in Table 4.8.4.3.

Table 4.8.4.3 Rf values obtained for the individual carotenoids in the *Phaffia rhodozyma* (mutant strain) extract

Carotenoid	Rf Value	Colour
Carotenoid 1	0.28	Orange / red
Carotenoid 2	0.49	Yellow / orange
Carotenoid 3	0.89	Orange
<i>trans</i> - astaxanthin (standard)	0.33	Orange / red
β -carotene (standard)	0.97	Yellow / orange

Carotenoid 1 was determined to be *trans* - astaxanthin on the basis of colour and Rf value. Carotenoid 3 was determined to be β -carotene, also on the basis of Rf value and colour. Based on Rf values obtained for individual carotenoids using TLC, the mutant strain of *Phaffia rhodozyma* is observed to have to have a carotenoid that was not detected in the parent strain, and on the basis of the Rf value of the pigment, and polarity during TLC, carotenoid 2 was determined to be Phenicoxanthin.

Mutant strains of *Phaffia rhodozyma* have exhibited changes in carotenoid composition from the parent strain, and carotenoids detected in the parental strain are often not detected in the mutant (An *et al.* 1989). The TLC analysis carried out in this research qualitatively demonstrated this, and allowed positive identification of the individual carotenoids in the parent and mutant strain of *Phaffia rhodozyma*.

Chapter Five

Discussion of Results

5.0 Discussion of Results.

5.1 Mechanical and enzymatic cell breakage

Astaxanthin is an oxygenated carotenoid pigment used as a dietary supplement for salmonids and crustaceans grown in aquacultural farms. One source of astaxanthin for aquacultural use is the yeast *Phaffia rhodozyma*. However, regardless of the pigment level in the yeast cell, efficient uptake by the digestive tracts of fish and subsequent deposition in the flesh will not occur, unless the cell walls are modified making the internal pigment available (Johnson *et al.* 1979). The *Phaffia rhodozyma* cell wall has a tough capsular coating, probably consisting of mannans and a α - 1, 3 - linked glucans which cannot be broken down by most animals. It is necessary to modify the cell walls, without altering the astaxanthin, before incorporation into animal feeds (Nelles *et al.* 1993).

Many methods have been employed to rupture the cell wall of *Phaffia rhodozyma* to allow the extraction of pigment from the cells. These include mechanical breakage, chemical treatment and enzymatic treatment. Mechanical and enzymatic treatment was investigated in this research, and each method compared in terms of their effectiveness at releasing pigment from the cells. Chemical treatment using acids was also investigated as a method of cell breakage, and was also used in combination with enzyme treatment.

Using the homogeniser to rupture the cell walls of *Phaffia rhodozyma* is one of the most common methods used to release pigment from the cells (Johnson *et al.* 1991). The duration of the homogenisation process varies greatly, with times ranging from three minutes (Johnson *et al.* 1979) to five minutes (Fleno *et al.* 1988) to seven minutes used (Prevatt *et al.* 1991). The volume of solvent used also varies greatly, with volumes used ranging from 10 mls (Prevatt *et al.* (1991)) to 20 mls (Johnson *et al.* 1979). The weight of beads used in the homogenisation process also varies greatly, and weights of beads from 0.025 g (Prevatt *et al.* 1991) to 1g (Calo *et al.* 1996) have been used. Therefore, a uniform method was needed which would allow standard conditions to be applied during the procedure, while still allowing the release of pigment from the cells.

The volume of solvent used in the homogenisation process did not affect the yield of astaxanthin obtained from the cells. However, the weight of beads used was shown to affect the yield of pigment obtained from the cells. The results indicated that the weight of beads used in the procedure was crucial to the amount of pigment released from the cells. The maximum yield of astaxanthin obtained from 1g of cells was recorded using 4.5 g of beads, irrespective of the volume of acetone used. A cell disintegration efficiency of 80.47 to 81.67% was recorded using this weight of beads (Table 4.1.3.1). Increasing the weight of beads used in the procedure did not result in an increase in pigment yield from the cells.

Approximately 20% of the cells containing pigment remained intact after homogenisation. Various studies have been carried out to determine the effectiveness of using a homogeniser to rupture *Phaffia rhodozyma* cells. One study found that six minutes homogenisation with a Gaulin homogeniser, using 0.25 g of beads and 10 mls of acetone, rendered 75% of the astaxanthin extractable (Torregrossa *et al.* 1991). Another study using a Gaulin homogeniser found that 5 minutes homogenisation using 20 mls of methanol and 15 g of beads allowed all the astaxanthin in the cells to be extracted, although no specific figures are quoted (Fleno *et al.* 1988). The percentage of astaxanthin extracted from *Phaffia rhodozyma* cells in this study was found to be over 80%, 5% higher than the maximum extraction percentage quoted in the literature (Torregrossa *et al.* 1991). However, the conditions applied during the homogenisation process in these studies were different to those employed in this research, and this may explain the difference in the extraction values.

Mechanical breakage using a Braun homogeniser was found to be 80% effective, allowing the release of 80% of the astaxanthin from *Phaffia rhodozyma* cells, under the conditions determined in this research to optimise pigment extraction. However, although homogenisation works well for small scale preparations, this technique is unsuitable for the large scale production of astaxanthin from *Phaffia rhodozyma*, due to the cost of the process and the length of time involved.

Enzymatic digestion is another method commonly used to rupture the cell wall of *Phaffia rhodozyma*. Okagbue *et al.* (1984) used autolysis to digest the cell wall of *Phaffia rhodozyma*. Okagbue *et al.* (1983) also experimented with the co-fermentation of *Phaffia rhodozyma* with *Bacillus circulans* WL-12 .

Bacillus circulans WL-12 produces enzymes during co-fermentation with *Phaffia rhodozyma* which partly digests the cell walls of the yeast.

Commercially available enzymes have also been used to digest the cell wall of *Phaffia rhodozyma*. Gentles *et al.* (1991) discovered that using the enzyme Fungelase to treat whole cells of *Phaffia rhodozyma* facilitated the extraction of astaxanthin into acetone. The use of other commercially available enzymes such as Novo Viscozyme, Novo Gamanase and Novo Ceremix was less successful. In all cases, each enzyme allowed less than 28% of astaxanthin to be released from the cells (Torregrossa *et al.* 1991). SP 299 Mutanase was also used to digest the cell walls of *Phaffia rhodozyma*. Using an enzyme concentration of 0.12 g/l, and a contact time of 43 hours, 95% of the astaxanthin was released from the cells (Torregrossa *et al.* 1991). Three enzymes were used in this study, and compared for effectiveness at digesting the cell wall of *Phaffia rhodozyma*.

Maximum percentage extraction of astaxanthin from the yeast cells was recorded using an enzyme concentration of 250 mg / ml, and a contact time of 24 hours (Figure 4.2.4). Gentles *et al.* (1991) suggested that increasing the contact time between the enzyme preparation and cells could increase the percentage extraction of pigment from *Phaffia rhodozyma* cells. However, the findings of this study indicated that increasing the enzyme concentration to 500 mg / ml and the contact time to 48 hours, did not result in an increase in the percentage extraction of pigment from the cells.

The greatest percentage extraction of astaxanthin was obtained using SP 299 Mutanase. Percentage extraction was used to measure the effectiveness of a specific enzyme at digesting the cell wall of *Phaffia rhodozyma*. The highest percentage extraction of astaxanthin was recorded using this enzyme. SP 299 Mutanase allowed 93.94% of pigment to be released from the cells (Figure 4.2.3), Novozyme 234 allowed 89.33% of pigment to be released (Figure 4.2.1), while Lyticase allowed 80.44% of pigment to be released from the cells (Figure 4.2.2).

The results obtained for percentage extraction of astaxanthin using Novozyme 234 and SP 299 Mutanase can be compared to those obtained in other studies using these enzymes. It can be observed that the results obtained in this study are higher than those quoted in the literature (Torregrossa *et al.* 1991).

However, Torregrossa *et al.* found SP 299 Mutanase to be the most effective enzyme preparation tested, in terms of percentage extraction of astaxanthin. This agrees with the finding obtained in this study.

More samples may be processed using enzyme treatment making it a more attractive than mechanical breakage, for use on a large scale basis. However, a potential drawback to enzyme treatment may be the cost, since the enzymes used are very expensive. This method of cell breakage may not be economically viable in a large scale operation as a result.

Various methods of chemical treatment have been used to treat *Phaffia rhodozyma* cells to render the astaxanthin extractable. A methylene chloride technique that was used with *Pichia lysis* was also tested on *Phaffia rhodozyma*. However, no breakage was induced using this method (Prevatt, W.D. 1991). Hydrochloric and sulphuric acids have been used to treat *Phaffia rhodozyma* cells to determine if lysis of the cell wall would occur. Using an elevated temperature of 60°C, treatment of *Phaffia rhodozyma* cells with hydrochloric acid allowed 90% of astaxanthin to be extracted, while treatment with sulphuric acid allowed 91% of astaxanthin to be extracted (Prevatt, W.D. 1991).

Acid lysis using hydrochloric and sulphuric acid was carried out in this study to determine if cell breakage would occur. Maximum percentage extraction recorded using hydrochloric acid was 31.33%, using a 2M concentration at a temperature of 60°C (Table 4.3.1). Maximum percentage extraction using sulphuric acid was 24.66%, also using a 2M concentration at a temperature of 60°C. These values are substantially lower than those quoted in the literature (Prevatt, W.D. 1991). However, maximum percentage extraction was recorded in this study using the same temperature of incubation and concentration of acid as that quoted in the literature.

Various researchers have recommended that acid lysis should be carried out prior to mechanical breakage, to maximise extraction of astaxanthin from the cells (Prevatt, W.D. 1991). This was not attempted in this study. The results obtained in this study indicated that acid lysis alone was an ineffective method of cell breakage, therefore, acid treatment was used prior to enzyme treatment with SP 299 Mutanase to determine if the percentage of astaxanthin extracted from the cells could be increased. The results obtained showed that using acid

lysis to pre-treat *Phaffia rhodozyma* cells prior to enzyme treatment increased the percentage of astaxanthin extracted from the cells.

Maximum extraction of pigment using a combination of hydrochloric acid lysis and enzyme treatment was 98.24%, an extraction value 4.31% higher than that recorded using enzyme treatment as the sole method of cell breakage (Table 4.4.1.1). Maximum percentage extraction using sulphuric acid lysis and enzyme treatment was 88.97%.

Maximum extraction of pigment was recorded using an incubation temperature of 60°C, and a 2M concentration of both acids. Increasing the incubation temperature above 60°C reduced the effectiveness of both acids at lysing the cells, most likely due to the degradation of the pigment, resulting in lower extraction percentages.

The results obtained in this study indicate that hydrochloric and sulphuric acid lysis aids in *Phaffia rhodozyma* cell breakage, when used with enzyme treatment. However, acid lysis is not effective when used as the sole method of cell breakage.

5.2 Comparison of various growth media

Phaffia rhodozyma was cultured in four different growth media, and growth curves were obtained using the viable and total cell counts. The longest lag phase was recorded using the substitute yeast malt broth to culture the organism. Cells remained in this phase of growth for 40 hours (Figure 4.5.1.1). Cells remained longest in the exponential phase of growth when *Phaffia rhodozyma* was cultured in the yeast malt broth, with cells remaining in this growth phase for 48 hours.

It is not clear why a longer lag phase was observed when a substitute yeast malt broth was used to culture *Phaffia rhodozyma*. This could be due to the yeast cells taking longer to adapt to this growth medium after transfer of the inoculating culture, resulting in slower growth and a longer lag phase.

The highest mean specific growth rate recorded was 0.185 μ / hr⁻¹, using the mineral salts medium to culture the organism (Table 4.5.1.1). No comparative figures are quoted in the literature. However, Johnson *et al.* (1979) recorded a

mean specific growth rate of $0.16 \mu / \text{hr}^{-1}$, when *Phaffia rhodozyma* was grown in fermenter culture at 20°C using a mineral salts medium. This value is lower than that recorded in this study using the same medium. However, this difference may be attributed to the different culture methods used.

The second highest mean specific growth rate recorded was $0.17 \mu / \text{hr}^{-1}$, when *Phaffia rhodozyma* was cultured in the yeast malt broth. Meyer *et al.* (1993) recorded a mean specific growth rate of $0.18 \mu / \text{hr}^{-1}$ for *Phaffia rhodozyma* when grown in a yeast malt broth at 22°C for 120 hours. The mean specific growth rate recorded in this study was the same as that recorded by Meyer *et al.* (1993). However, it must be noted that the growth rate recorded by Meyer *et al.* was recorded after a longer incubation time than that used in this study.

The lowest mean specific growth rate recorded was $0.12 \mu / \text{hr}^{-1}$, when *Phaffia rhodozyma* was cultured in the rich assay growth medium. No specific values were quoted in the literature when *Phaffia* was cultured in either the rich assay growth medium or the substitute yeast malt broth. Therefore, no comparisons may be made to the results obtained in this study using these media.

The specific growth rate was used to determine which media supported the best growth of *Phaffia rhodozyma*. Therefore, the mineral salts medium and yeast malt broth were determined to be the best media at supporting the growth of *Phaffia rhodozyma*.

In subsequent research carried out in this project, yeast malt broth and the mineral salts medium were the media chosen to culture *Phaffia rhodozyma*, on the basis of the results obtained in this section of the research.

5.3 Effect of the addition of glucose on growth and pigment production by *Phaffia rhodozyma* grown in batch culture

Yields of biomass and pigment produced by *Phaffia rhodozyma* grown in the control culture using a 1.5% carbon source, were greater than those obtained in the control culture using 1% glucose (Figures 4.7.2.1 and 4.7.2.5). In both control cultures however, biomass and pigment yields increased up to 120 hours, after which time the yields decreased. The greatest increase in pigment yield in a 24 hour period was obtained using a 1% carbon source, when a two fold increase of 81 mg pigment was recorded between 72 and 96 hours of

growth. The biggest increase in pigment production using 1.5% glucose was also obtained at this time, when an increase of 46.04 mg pigment was recorded. The biggest increase in biomass yield recorded during any 24 hour period, was obtained between 72 and 96 hours of growth, using a 1.5% carbon source. Maximum pigment yield at a 1% glucose concentration was 159.27 mg pigment, while maximum pigment yield at a 1.5% glucose concentration was 184.27 mg / 25 mls culture fluid.

Astaxanthin production in the cultures where no additional substrate was added followed the same pattern as biomass production. Yields of pigment and biomass increased up to 120 hours, then decreased. The addition of fresh glucose at concentrations of 1% and 1.5%, did not result in an increase in biomass yields (Figure 4.7.2.2), but did result in an increase in the yield of pigment from the cells (Figure 4.7.2.6). The addition of fresh substrate to the cultures at both concentration used, also resulted in an increase in cell numbers (Figure 4.7.2.4).

Meyer et al. (1993) reported that during a batch fermentation of *Phaffia rhodozyma*, after the addition of fresh glucose to the culture at a concentration of 2%, an increase in biomass and astaxanthin yields was observed. The results obtained in this research support this finding. However, another study reported that supplementing a batch culture of *Phaffia rhodozyma* after 120 hours of growth with 1% glucose, produced an increase in biomass yields, but no increase in pigment yields (Grant, S.M., Healy, M.G., and Murphy, W.R. 1994). It must be noted that the results recorded by Grant *et al.* (1994) were obtained using a different method of culture to that used in this study, and may explain the difference in the results.

Consumption of the carbon source in both control cultures followed a similar pattern (Figure 4.7.2.7). Consumption of the glucose at a 1% concentration was more rapid than at the higher concentration used. After 240 hours of growth 0.88% of the 1% carbon source remained in the medium, while 3.65% of the 1.5% carbon source remained (Figure 4.7.2.9).

After the addition of fresh glucose to the cultures at both concentrations used, consumption of the additional substrate proceeded rapidly (Figure 4.7.2.8). In the culture where additional 1% glucose was added after 120 hours 81.48% of the fresh substrate remained 24 hours after addition. After 240 hours, only

8.67% of the additional carbon remained in the medium. In the culture where 1.5% glucose was added after 120 hours, 87.5% of the additional glucose remained in the medium 24 hours later. After 240 hours of growth, 7.83% of the additional glucose remained in the medium (Figure 4.7.2.10). As the addition of glucose resulted in an increase in pigment yield and cell numbers, the rapid consumption of the additional substrate would be expected. Consumption of the additional glucose was more rapid at the higher concentration used.

Statistical analysis was carried out on the data generated in this section of research, to determine the extent of correlation, if any, between the four test parameters. Negative correlation was observed to exist between consumption of the carbon source and cell growth, biomass production, and pigment production, for all four cultivations. Stronger negative correlation was observed to exist between glucose consumption and cell growth, than existed between glucose consumption and both biomass and pigment production. This is expected, since research has shown that nutrient sources are initially used by *Phaffia rhodozyma* solely for growth, with surplus carbon then used to build the forty carbon chain of astaxanthin (Johnson *et al.* 1991).

Two of the results obtained for correlation between glucose usage and both biomass and pigment production, for the cultures supplemented with 1% and 1.5% glucose were not statistically significant at the 95% confidence level. These correlation coefficients were very low. The addition of fresh substrate to the cultures would have upset the relationship between glucose usage and pigment production, since negative correlation implies that large values of y (pigment) would occur with small values of x (glucose). Once additional substrate was added to this culture, this relationship would not apply.

The results obtained in this section of research indicate that the addition of fresh glucose to a culture, at concentrations of 1% and 1.5%, results in an increase in cell numbers and pigment yields.

The 'fed batch' mode of adding additional carbon to the growth medium is effective at producing increased cell numbers, and pigment yields. This would suggest that a fed batch system of culture for *Phaffia rhodozyma* would be more effective than a batch system, at increasing pigment yield.

5.4 Cultivation of the parent strain (NCYC 874) and a mutant strain (NRRL-Y-18734) of *Phaffia rhodozyma* in shake flask culture

Biomass production by the parent strain of *Phaffia rhodozyma* followed the same pattern observed for astaxanthin production. This finding is supported by Johnson *et al.* (1979) who reported that astaxanthin production by *Phaffia rhodozyma* is growth associated. Yields of pigment and biomass produced by the cells increased up to 120 hours, with maximum biomass and pigment production occurring at this time. After 120 hours of growth, the yields of pigment and biomass produced by the parent strain decreased (Figures 4.6.2.1 and 4.6.2.2).

Biomass and pigment production by the mutant strain of *Phaffia rhodozyma* followed a different pattern however, with the yields of pigment and biomass produced by the yeast increasing over 240 hours (Figures 4.6.2.17 and 4.6.2.18). Pigment yields produced by the mutant strain were 3 to 4 times greater than the yields produced by the parent strain of the yeast. Calo *et al.* (1995) also observed that mutants of *Phaffia rhodozyma* produce much greater yields of pigment than the parent strain of the yeast. In some cases, mutants contained 232% more pigment than the parent strain.

The maximum yield of biomass produced by the parent strain when cultured in the yeast malt broth was 234 mg per 25 mls of culture fluid, and the maximum yields of pigment produced by the parent strain was 238 mg / 25 mls of culture fluid. Meyer *et al.* (1993) obtained a maximum biomass yields of 168.22 mg, and a maximum pigment yield of 297 mg, when the parent strain (CBS 5905T) of *Phaffia rhodozyma* was grown in shake flask culture using a yeast malt broth. The parent strain of *Phaffia rhodozyma* used in this study produced greater yields of biomass than those recorded by Meyer *et al.* (1993), but lower pigment yields were recorded in this study using strain NCYC 874 of *Phaffia rhodozyma*.

The same pattern can be observed as regards biomass and pigment yields produced by the mutant strain in this study, when grown in a mineral salts medium. Meyer *et al.* (1993) obtained lower biomass yields and higher pigment yields when a different mutant strain of *Phaffia rhodozyma* (M4) was grown in shake flask culture using the same medium.

The maximum yields of biomass produced by the parent strain of the yeast when cultured in the mineral salts medium was 3733.55 mg per 25 mls of culture fluid, while the maximum yield of pigment produced was 521.40 mg per 25 mls of culture fluid. The yields of biomass and pigment produced by the parent strain in this study (NCYC 874) are greater than those recorded by Evans *et al.*(1991), when the parent strain was grown in shake flask culture using a mineral salts medium. The same pattern can be observed regarding the yields of biomass and pigment produced by the mutant strain (NRRL-Y-18734) used in this study. Greater pigment and biomass yields were produced by the mutant strain used in this study, than were recorded by Evans *et al.*(1991) using the same growth medium to culture a mutant strain (ENZA M10) of *Phaffia rhodozyma*.

The growth of the parent and mutant strain of *Phaffia rhodozyma* was observed to follow the same pattern, with cell numbers increasing over 240 hours (Figures 4.6.2.3 and 4.6.2.19).

Glucose consumption by the parent and mutant strain of *Phaffia rhodozyma* followed a similar pattern (Figure 4.6.2.4). During the first 24 hours of growth, the parent strain consumed 47.31% of the carbon source, while the mutant strain consumed 38.42% during the same period. Glucose consumption was rapid over the next 96 hours, as biomass and pigment yields produced by both strains of the yeast are increasing. Maximum biomass and pigment yields are produced by the parent strain after 120 hours of growth, when 4.3% to 5.09% of the carbon source remains in the medium. The depletion of the carbon source results in a decrease in biomass production, and this finding is supported by Johnson *et al.* (1979), who reported that termination of growth coincides with the exhaustion of glucose from the growth medium. Even though just 4.06% to 5.51% of the carbon source remains available to the mutant strain at this time, biomass and pigment production continue to increase. This would seem to suggest that the mutant strain of *Phaffia rhodozyma* is more efficient than the parent strain at utilising the carbon source. This may explain why there is an increase in both biomass and pigment production, even though just 5% of the carbon source remains in the medium.

Consumption of the nitrogen source by the parent and mutant strain of *Phaffia rhodozyma* follows a different pattern to that observed with glucose consumption (Figure 4.6.2.12). Consumption of nitrogen remains steady over

240 hours. The parent strain consumes less of the nitrogen source than the mutant strain, with 33.37% of the nitrogen source available to the parent strain after 240 hours of growth, while 17.50% of the nitrogen is available to the mutant strain after this time. This may indicate that the mutant strain is also more efficient than the parent strain at utilising the nitrogen source. This may explain why biomass and pigment yields produced by the mutant strain increase over 240 hours, while the yields produced by the parent strain decreases.

Very little work has been published with regard to consumption of nitrogen by *Phaffia rhodozyma*. Therefore, no data is available which would allow comparisons to be made with the findings obtained in this study. However, in a study carried out by An *et al.* (1989), it was reported that mutant strains of *Phaffia rhodozyma* derived using antimycin mutagenesis, grew slower than the parent strain on various nitrogen sources. The results obtained for nitrogen consumption by the mutant strain (NRRL-Y-18734) used in this study contradicts this finding, as the mutant strain consumed approximately twice as much of the nitrogen source as the parent strain of the yeast. However, it must be noted that the findings obtained in the study carried out by An *et al.* (1989), were obtained using mutants of *Phaffia rhodozyma* derived using different treatments to those used to produce the mutant used in this study.

The mutant strain used in this research was created by subjecting the parent strain (NCYC 874) of *Phaffia rhodozyma* to a series of mutagenic treatments using NTG and EMS together with UV treatment, and this seems to have produced a mutant that is more efficient than the parent strain at utilising carbon and nitrogen.

Statistical analysis of the data produced in this section of research, was carried out to determine the extent of correlation, if any, between the various test parameters.

Positive correlation was observed to exist between the production of biomass and pigment by both strains of *Phaffia rhodozyma*. Positive correlation was also observed to exist biomass and growth for both strains of the yeast. In both cases, the positive correlation results obtained when the parent strain was cultured in a yeast malt broth, were not found to be statistically significant. Positive correlation was observed to exist between biomass production and

growth for both the parent and mutant strain, although the results obtained for the parent strain were not statistically significant. These results indicate that the production of biomass and pigment by *Phaffia rhodozyma* is linked. Johnson *et al.*(1979) also observed that astaxanthin production by *Phaffia rhodozyma* is growth associated, but stated that pigment production did not exactly coincide with an increase in biomass.

Negative correlation was observed to exist between consumption of glucose by both strains of the yeast, and the production of pigment and biomass. Negative correlation was also observed to exist between growth (as measured by optical density) and glucose consumption by both strains of the yeast. This indicates that glucose consumption is closely linked to biomass and pigment production by *Phaffia rhodozyma*. However, stronger negative correlation was observed to exist between consumption of the nitrogen source by the parent strain, and biomass production. This indicates that nitrogen consumption by the parent strain is more closely linked to the production of biomass, than to the consumption of the carbon source. Negative correlation was observed to exist between consumption of the nitrogen source and growth of the yeast. As nitrogen is consumed, biomass and pigment yields increase, as do the optical density measurements. Stronger negative correlation was observed to exist between glucose consumption and growth of both strains of *Phaffia rhodozyma*. This is to be expected, since consumption of the carbon source by *Phaffia rhodozyma* has been shown to be primarily linked to cell growth (Johnson *et al.* 1991).

The negative correlation results obtained for pigment production and glucose consumption by both strains of is interesting. Stronger correlation was observed to exist between glucose consumption and pigment production by the parent strain, while pigment production by the mutant strain was found to be more strongly linked to consumption of the nitrogen source. These results indicate that the parent and mutant strains of *Phaffia rhodozyma* utilise the carbon and nitrogen sources differently, with the nitrogen source utilised by the parent strain to produced biomass, while the carbon source was utilised to produce pigment. The mutant strain utilised the nitrogen source to produce pigment, while the carbon source was used in the production of biomass and cell numbers.

5.5 Cultivation of the parent strain (NCYC 874) and a mutant strain (NRRL-Y-18734) of *Phaffia rhodozyma* in a 2L laboratory fermenter

Biomass production by the parent strain of *Phaffia rhodozyma* followed a different pattern to that observed when the parent strain was grown in shake flask culture (Section 4.6). When the parent strain was grown in the fermenter (Figure 4.8.2.1), biomass production began after an initial lag period of 20 hours, which was similar to the length of the lag phase observed by Johnson *et al.* (1979). Biomass and pigment production (Figure 4.8.2.3) decreased after 120 hours of growth, when cells entered the stationary phase. The parent strain produced greater yields of both pigment and biomass when cultured in the fermenter. Biomass and pigment yields decreased after 120 hours when the parent strain was grown in shake flask culture. The fermenter allowed *Phaffia rhodozyma* to grow in a controlled environment where conditions are carefully monitored. Temperature, pH and dissolved oxygen were all carefully controlled in the fermenter. Johnson *et al.* (1979) reported that at low oxygen dissolution rates, yeast and astaxanthin yields were greatly reduced. Dissolved oxygen can become limiting in shake flasks, but dissolved oxygen level remained above 50% during the cultivation of the parent strain in the fermenter. This could explain the increase in biomass and pigment yields produced by the parent strain after 120 hours, in the fermenter.

Growth (as measured by optical density) of the parent strain followed the same pattern as observed during shake flask culture (Figure 4.8.2.2). Consumption of nitrogen by the parent strain was not as rapid as when the parent strain was grown in shake flask culture (Figure 4.8.2.12). There is no clear explanation for this. Nitrogen consumption was observed to have an effect on pigment and biomass production by the parent strain when grown in shake flask culture. However, yields of pigment and biomass increased when the parent strain was grown in the fermenter, even though there was less consumption of the nitrogen source.

Glucose consumption by the parent strain was observed to be more rapid by the parent strain when cultured in the fermenter. Johnson *et al.* (1979) reported that after 60 hours of growth in fermenter culture using a 1.5% carbon source, the glucose was exhausted from the medium. The results obtained in this study dispute this finding. 4.47% of the carbon source remained after ten days

growth of the parent strain in shake flask culture, while 3.16% glucose remained after 180 hours growth in the fermenter.

Biomass and pigment production by the mutant strain of *Phaffia rhodozyma* followed the same pattern as observed when the mutant was grown in shake flask culture. In both cases, biomass (Figure 4.8.2.1) and pigment (Figure 4.8.2.3) yields produced by the mutant increased up to 120 hours of growth, and remained constant after that time. Growth of the mutant strain (as measured by optical density) also followed the same pattern as observed when the mutant was grown in shake flask culture. Optical density measurements recorded when the mutant was grown in the fermenter, were higher than those recorded for the mutant during shake flask culture (Figure 4.8.2.2). Pigment production by the mutant strain cultured in the fermenter also followed the same pattern as observed when the mutant was grown in shake flask culture.

The maximum yield of pigment produced by the parent strain when grown in the fermenter was 2712 mg of pigment per g of cells, while the mutant strain produced a maximum yield of 3622 mg per g of cells. These values are higher than those cited in the literature. Johnson *et al.* (1979) reported a maximum pigment yield of 406 mg per g of cells, when the parent strain of *Phaffia rhodozyma* was cultured in a 2l fermenter. Fang *et al.* (1993) obtained a maximum pigment yield of 1633 mg per g of cells, when a mutant strain of *Phaffia rhodozyma* (NCHU-FS301) was cultured in a 2l fermenter.

The maximum yield of biomass produced by the parent strain cultured in the fermenter was 6.293 g / l, while the mutant strain produced a maximum yield of 14.323 g / l. Again, these values are higher than those cited in the literature. Johnson *et al.* (1979) obtained a maximum biomass yield of 6.04 mg / l, while Fang *et al.* (1993) reported a maximum biomass yield of 6.657 g / l, when a mutant strain of *Phaffia rhodozyma* was cultured in a 2l fermenter. However, the culture conditions employed in these studies were different to those employed in this research, and would explain the difference in the yields of biomass and pigment produced by the yeast.

Glucose consumption by the mutant strain was very rapid, and followed the same pattern observed for the parent strain (Figure 4.8.2.8). As biomass and pigment yields increased so did consumption of the carbon source. This was the same pattern as observed when the mutant was grown in shake flask

culture. Nitrogen consumption also followed the same pattern as observed with shake flask culture of the mutant strain (Figure 4.8.2.12). The pattern of growth, biomass and pigment production, and glucose and nitrogen consumption by the mutant strain cultured in the fermenter followed a similar pattern as when the mutant was grown in shake flask culture, and indicates that the mutant can produce higher yields of biomass and pigment than the parent strain, irrespective of the culture method used.

No information on the consumption of nitrogen by *Phaffia rhodozyma* was available in the literature. Therefore, no comparisons may be made with regard to the results obtained in this study.

The statistical error of the means obtained for the various parameters during fermenter culture of the parent and mutant strain of *Phaffia rhodozyma* are lower than those obtained when the strains were grown in shake flask culture. The fermenter is a more controlled environment than the shake flask system, and less erroneous would be expected.

Statistical analysis of the data generated in this section was carried out to determine the extent of the correlation between the test parameters. Positive correlation was found to exist between pigment and biomass production by the parent and mutant strain of *Phaffia rhodozyma*. As biomass production increased, so too did pigment production. This is to be expected since pigment production has been shown to be growth related (Johnson *et al.* 1979). This was also observed when the parent strain was grown in shake flask culture. This indicates that the correlation existing between biomass and pigment production by the mutant strain is stronger than that existing between pigment and biomass production by the parent strain.

Positive correlation was observed to exist between biomass production and growth and pigment production and growth by the parent and mutant strain of *Phaffia rhodozyma*. Stronger correlation was observed to exist between pigment production and growth by the mutant strain. This was also observed when the parent and mutant strains were grown in shake flask culture.

Negative correlation was found to exist between glucose consumption and both pigment and biomass production by the parent and mutant strains. This indicated that the mutant strain is more efficient than the parent strain at

utilising carbon for both pigment and biomass production. This follows the pattern during shake flask cultivation of the parent and mutant strains. Negative correlation was also found to exist between glucose consumption and growth of the parent and mutant strain. This was also observed when both strains were grown in shake flask culture.

Negative correlation also existed between nitrogen consumption and biomass production by both strains of *Phaffia rhodozyma*. Correlation was found to be more statistically significant for the parent strain, indicating that biomass production by the parent strain is more strongly linked to nitrogen consumption, while pigment production is more strongly linked to glucose consumption. Nitrogen consumption by the mutant strain was found to be more strongly linked to pigment production. This agrees with the previous claim made (Section 4.6) that the mutant strain utilises more of the nitrogen source to produce pigment, and uses more of the carbon source to produce biomass. The parent strain uses glucose mainly for production of pigment, and uses nitrogen mainly for biomass production. The parent strain and mutant strain of *Phaffia rhodozyma* utilise carbon and nitrogen differently when grown in both shake flask and fermenter culture.

The results obtained in this section indicate a close similarity between biomass and pigment production by the parent and mutant strain when grown in both shake flask and fermenter culture. The results obtained in this section also indicate a close similarity between growth, and glucose and nitrogen consumption by both strains when grown in both fermenter and shake flask culture. Pigment and biomass yields produced by the yeast were greater when both strains were grown in the fermenter.

Chapter Six

Conclusions

6.0 Conclusions

Astaxanthin is the carotenoid pigment that produces the pink colour found in the flesh of salmon and trout, and the shells of lobsters and shrimp. These animals are unable to synthesise their own astaxanthin, but rather acquire it from algae in the food chain (Goodwin, T.W. 1972). The addition of a synthetic version of this pigment to feeds is the current mode of pigmentation used in intensive salmonid farming.

There is considerable interest in the use of natural sources of astaxanthin as pigmenters, due to the reluctance of many consumers to have synthetic substances present in the food chain. The psychrophilic red yeast *Phaffia rhodozyma* has considerable potential as an astaxanthin source for this market. Recent advances in isolating high carotenoid producing strains of *Phaffia rhodozyma* have meant that *Phaffia rhodozyma* remains a very attractive natural source of astaxanthin (Prevatt *et al.* 1991).

The use of *Phaffia rhodozyma* as a commercial source of astaxanthin is dependant on the isolation of strains that will stably produce ~ 10,000 µg / g astaxanthin in industrial fermenters, as well as the utilisation of sugar waste streams as inexpensive growth substrates. Several approaches have been taken to improve the astaxanthin yield from *Phaffia rhodozyma*. These include the use of various mutagenic techniques, and studying the effect of culture conditions. Mutants have been isolated that produce levels of pigment as high as 15,000 µg / g yeast (Johnson *et al.* 1995). The approach taken in this work was based on analysis of culture conditions. The impact of the addition of fresh carbon during culturing was studied to determine whether a fed-batch mode of culture would be an effective means of increasing pigment yields from the cells.

The work carried out comprised four areas of investigation. The first was preliminary investigations, which was used to determine the most effective method of cell breakage and pigment release. The findings of these investigations had a direct effect on the other sections of this work, since the cell breakage methods used throughout the experiments were those found to be most effective during the preliminary investigations.

Mechanical cell breakage was found to be the least effective method of cell breakage, even though homogenising conditions were optimised. A maximum disintegration of 81.67% was recorded using the homogeniser. Enzymatic digestion of *Phaffia rhodozyma* cells was also investigated using three enzyme preparations. The most effective enzyme preparation tested was SP 299 Mutanase, using an enzyme concentration of 250 mg per ml after 24 hours contact time.

Using hot acid lysis as the sole method of cell breakage was found to be ineffective. However, pre-treatment of *Phaffia rhodozyma* cells with hot hydrochloric acid at a 2M concentration, using an incubation temperature of 60°C followed by enzyme treatment with SP 299 Mutanase, released 98.24% of the pigment from the cells. During all shake flask experiments carried out in this research yeast cells were ruptured using mechanical cell breakage, under the optimum operating conditions determined during the preliminary investigations. However, samples taken from the fermenter were subjected to acid lysis and enzyme treatment, since the preliminary investigations determined this to be the most effective method of cell breakage.

The analytical methods used during experiments were those found to be the simplest and most effective. Optical density measurement is a widely used method of growth analysis, and is known to be reliable. The spectrophotometric assay method of pigment analysis is not the most accurate available (Johnson *et al.* 1991) However, the spectrophotometric method is quick and easy to use, and given the low error obtained using this method, pigment yields produced by the cells were quantified using the spectrophotometric method of analysis.

Once the basic experimental techniques had been decided the next step was to choose a growth medium which would support good growth and pigmentation of *Phaffia rhodozyma*. Four growth media were investigated, and two were chosen on the basis of specific growth rates. Yeast Malt Broth and a Mineral Salts Medium were both used to culture the yeast on the basis of these results.

The next step in this research looked at the production of pigment and biomass by the parent strain (NCYC 874) and a mutant strain (NRRL-Y-18734) of *Phaffia rhodozyma* when grown in shake flask culture using a Yeast Malt Broth and a Mineral Salts Medium.

Pigment and biomass production by both strains of *Phaffia rhodozyma* were observed to follow a different pattern in shake flask culture. Biomass and pigment production by the parent strain increased up to 120 hours, then decreased. Biomass and pigment production by the mutant strain increased over 240 hours. Growth of both strains followed a similar pattern. Glucose consumption by both strains was rapid, with both consuming over 95% of the carbon source during the first 120 hours of growth. The pattern of nitrogen consumption was different. Less nitrogen was consumed by the parent strain with 33.37% remaining in the growth medium after 240 hours of growth. The mutant strain consumed twice as much nitrogen as the parent strain, with just 17.50% remaining in the medium after 240 hours. The results obtained here indicated that the parent and mutant strain of *Phaffia rhodozyma* utilised carbon and nitrogen differently. The mutant strain seems to be more efficient at utilising carbon, hence the increase in biomass and pigment production during 240 hours of culturing. Even though less than 5% of the carbon source remains available to the mutant after 120 hours of growth, biomass and pigment production continues to increase. This suggests that the mutant has the capacity to store glucose, and utilise it once the carbon in the medium has been depleted. The parent strain does not seem to have this capacity. Biomass and pigment levels decrease once the carbon source has been depleted. The mutagenic treatment carried out on the mutant may be responsible for this.

The statistical analysis of the data generated in this section of research was carried out to determine the extent of correlation, if any, between the test parameters. The results of this analysis indicated that biomass production by the parent strain is more closely linked to nitrogen consumption, while pigment production was found to be more strongly linked to glucose consumption. Pigment production by the mutant strain was more strongly linked to nitrogen consumption, while biomass production was more strongly linked to glucose consumption. This result differs from those published in earlier work by Johnson and Lewis (1979), who stated that the parent strain of *Phaffia rhodozyma* utilised glucose primarily for growth, while excess carbon was used to produce astaxanthin.

The mutant produced ten to fifteen times more biomass than the parent strain, and almost four times as much pigment. This indicates that the use of mutant strains of *Phaffia rhodozyma* could result in an economically viable astaxanthin production process. These results also showed that pigment production by

Phaffia rhodozyma was not limited to the exponential growth phase, and this would increase the fermentation time and production cost of the process. This must be borne in mind when looking at the commercial production of astaxanthin from *Phaffia rhodozyma*.

Once biomass and pigment production by *Phaffia rhodozyma* was investigated using shake flask culture, the next step involved scaling up to a 2l laboratory fermenter. Biomass production by the parent and mutant strains followed a different pattern to that observed during shake flask culture. The parent strain produced increased yields of biomass and pigment over 180 of culturing when grown in the fermenter. Dissolved oxygen can become limiting in shake flask culture, but the dissolved oxygen level remained above 50% in the fermenter. pH, temperature and agitation speed were all controlled in the fermenter, and could explain the increase in biomass and pigment yields produced by the parent strain. Growth and glucose consumption by the parent and mutant strains followed the same pattern as observed during shake flask culture. Less nitrogen was consumed by the parent strain of the yeast when grown in the fermenter, however, there is no clear explanation for this.

Pigment and biomass production, growth, and glucose and nitrogen consumption by the mutant strain followed the same pattern as observed during shake flask culture. Greater pigment and biomass yields were produced by the mutant when grown in the fermenter. As observed previously, statistical analysis of the fermenter data showed that the parent and mutant strain of *Phaffia rhodozyma* used carbon and nitrogen differently. The mutant used more of the nitrogen to produce pigment, and more of the carbon to produce biomass. The parent strain used nitrogen to produce biomass, and glucose for pigment production and growth. Both strains of *Phaffia rhodozyma* consumed more carbon and nitrogen when grown in the fermenter.

Research has shown that the pattern of astaxanthin formation differs for the parent and mutant strains of *Phaffia rhodozyma* (Prevatt *et al.* 1991). At present two pathways are suspected, one of which has a bicyclic precursor and one which has a monocyclic precursor. The difference in astaxanthin formation is due to the mutagenic treatment carried out on the parent strain of *Phaffia rhodozyma* to produce mutants (Johnson *et al.* 1991). This research has shown that the parent and mutant strains utilise carbon and nitrogen differently, and this is also due to the genetic differences between the parent and mutant

strain of the yeast. The results obtained in this work also indicate that the mutant strain of *Phaffia rhodozyma* has more potential for use in the commercial exploitation of this source of astaxanthin, since the mutant strain produced much higher biomass and pigment yields than the parent strain. Pigment and biomass production by the mutant was also more consistent, and indicates that the mutant can stably produce high amounts of both biomass and pigment when grown in a batch culture.

Culturing of *Phaffia rhodozyma* should provide a high cell mass and optimum astaxanthin concentration in the shortest time. Culturing can be carried out by one of three methods, two of which were used in this research. The first of these is batch fermentation, where maximum growth occurs during the exponential growth phase, due to a high cell mass. This leads to an increase in oxygen demand which can be expensive and complicated on a large scale. This must be considered in relation to *Phaffia rhodozyma* cultivation, since the required end-product, astaxanthin, is synthesised during the late exponential and early stationary growth phases.

Fed-batch fermentation is where substrate is added in accordance with the demands of the organism, and the growth rate is controlled due to controlled substrate addition. An adequate oxygen supply can be maintained. Fermentative respiration is avoided, therefore there is optimum substrate usage and biomass production, and high availability of oxygen contributes to good pigment production. Continuous fermentation involves replacing some of the spent medium with new medium. It is not a feasible option for *Phaffia rhodozyma* cultivation since astaxanthin production increases after cell growth has ceased. Continuous fermentation is more expensive and a longer fermentation times means that stricter sterile conditions are required than with the other two methods of culturing.

The fed-batch mode of culture was investigated as a means of increasing pigment production by *Phaffia rhodozyma*. The addition of fresh glucose to the culture after 120 hours, at concentrations of 1% and 1.5%, resulted in an increase in pigment yields. The results indicated that the addition of glucose during culturing is an effective method of increasing pigment yields from *Phaffia rhodozyma* cells. This would support the use of a fed-batch system for the commercial production of astaxanthin from *Phaffia rhodozyma*, as opposed to continuous culture.

Economic considerations play a part in the investigation of new processing routes to astaxanthin. Salmon and trout aquaculture has increased to 600,000 metric tonnes in 1991, and by the year 2000 salmonid and crustacean farming is expected to be worth more than 40 billion dollars worldwide (Rosenberry, 1993). Synthetic astaxanthin costs about 2,500 dollars (US) per kg, with an estimated market value of 80 to 100 million dollars per year. The market for astaxanthin will increase as the aquaculture of salmon, trout and crustaceans increases, and pigments and other nutrients produced by biotechnology will gain an increasing market share. Astaxanthin is an excellent example of a compound derived from biotechnology, because the chemical synthesis is rather difficult and expensive, and the biological process may become competitive with further development (Johnson *et al.* 1995).

The first step in the production of pigment from *Phaffia rhodozyma* is the fermentation of the yeast. The production of brewers yeast is carried out using a similar procedure. Fermentation of *Phaffia rhodozyma* with an optimum astaxanthin content will be more expensive than fermentation of brewers yeast since the growth of *Phaffia rhodozyma* is slower. Also, astaxanthin production is not limited to the exponential phase, increasing fermentation time and production costs. Holding the temperature below 25°C requires cooling, and this is expensive.

The optimisation of astaxanthin yield and the income this would generate must be compared to implementing a fed-batch system, not a batch system. Extra costs incurred as a result of using this system include a longer culture time that is associated with this type of culture, additional costs of raw materials and the additional cost of labour since the additional substrate must be physically added to the culture. These cost must be taken into account when investigating the commercial production of astaxanthin from *Phaffia rhodozyma*.

The economic viability of astaxanthin production from *Phaffia rhodozyma* will increase when cheaper substrates are used to culture the yeast, and when high producing mutants are used to produce pigment.

Commercial production of astaxanthin from *Phaffia rhodozyma* has been carried out by Gist Brocades (Netherlands). Their product 'Natupink' is a spray dried pellet which is added to the feed of aquatic species. However,

registration has not been granted for this product in the United States or Europe.

One of the aims of this project was to investigate pigment production by the parent strain and a mutant strain of *Phaffia rhodozyma* in batch culture. This was achieved, although further work is needed with regard to the use of carbon and nitrogen by the mutant strain, since more efficient usage of carbon and nitrogen seems to have resulted in increased yields of biomass and pigment. Another aim of this research was to determine how pigment production by *Phaffia rhodozyma* could be increased. This was achieved using a fed-batch system of culture, and pigment yields increased after the addition of fresh substrate to the culture. Successful commercialisation of *Phaffia rhodozyma* as a natural source of astaxanthin will involve the use of mutant strains of the yeast together with fed-batch culture, to optimise pigment yields.

Another aim of this work was to look at the extraction of astaxanthin from *Phaffia rhodozyma*, and the maximisation of cell breakage. This was achieved using a combination of pre-treatment with hot hydrochloric acid, followed by enzyme treatment using SP 299 Mutanase. Less than 3% of the cells remained intact after treatment.

Some of the findings of this work indicated that further work should be carried out on culture conditions. For example, it would have been advantageous to have tested for evidence of repression of respiration, to explain the fact that no increase in biomass or pigment yields were obtained using a higher concentration of glucose (1.5%). This may be of benefit to other researchers, since it has been shown that pigment production by *Phaffia rhodozyma* is repressed using increased glucose concentrations (de Haan *et al.* 1991). It would also have been advantageous to monitor the dissolved oxygen concentration during shake flask culture experiments.

A better technique for the quantification of astaxanthin from *Phaffia rhodozyma* is needed, that produces less erroneous results. There is also a need for on-line testing of intermediate products during the culturing of the yeast, to more fully understand the biochemical process that are taking place.

As stated previously, the most likely culture system for *Phaffia rhodozyma* which would produce optimum astaxanthin yields, is fed-batch culturing. A study of this system in terms of economic considerations should be undertaken.

The most likely options for biological production of astaxanthin are *Rhodotorula rubra* and *Phaffia rhodozyma*. The development of other 'natural' sources of astaxanthin mean that novel processing techniques and the use of high producing mutant strains of *Phaffia rhodozyma* are necessary to ensure the competitiveness and commercial feasibility of using this yeast as an astaxanthin source.

References

Acheampong, E.A., and Martin, A.M. (1995) Kinetic studies on the yeast *Phaffia rhodozyma*. J.Basic Microbiol. **35**(3):147-155

Adrio, J., Lopez, M., Casqueiro, J., Fernandez, C., and Viega, M. (1995) Electrophoretic karyotype of the astaxanthin-producing yeast *Phaffia rhodozyma*. Curr.Genetics. **27**:447-450

Adrio, J., and Viega, M. (1995) Transformation of the astaxanthin-producing yeast *Phaffia rhodozyma*. Biotechnology Techniques. **9**(7):509-512

An, G.H., Schumann, D.B., and Johnson, E.A. (1989) Isolation of *Phaffia rhodozyma* mutants with increased astaxanthin content. Appl.Environ.Microbiol. **55**(1):116-124

An, G.H., and Johnson, E.A. (1990) Influence of light on growth and pigmentation of the yeast *Phaffia rhodozyma*. Antonie van Leeuwenhoek. **57**:191-203

An, G.H., Bielich, J., Auerbach, R., and Johnson, E.A. (1991) Isolation and characterisation of carotenoid hyperproducing mutants of yeasts by flow cell cytometry and cell sorting. Biotechnology. **9**:70-73

An, G.H. (1993) Selection and evaluation of astaxanthin over-producing mutants of *Phaffia rhodozyma*. World Journal of Micro. and Biotechnol. **9**:514-520

Andersen, L.K. (1975) Extraction of carotenoid pigments from shrimp processing waste. U.S.Patent. No. 3,906,112

Andrewes, A.G., Phaff, H.J., and Starr, M.P. (1976) Carotenoids of *Phaffia rhodozyma*, a red pigmented fermenting yeast. Phytochemistry. **15**:1003-1007

Andrewes, A.G., and Starr, M.P. (1976) (3R,3'R)-Astaxanthin from the yeast *Phaffia rhodozyma*. Phytochemistry. **15**:1009-1011

Arpin, N., Lebneton, J., and Fiasson, J.L. (1966) Reserches chimiotaxinomiques sur le champignons. II. Les carotenoides de *Peniphora aurantiaca* (Bres.) (Basidiomycete). Bulletin de la Societe de Mycologie de France. **82**:450-459

Asknes, A., Gjerde, B., and Roalds, O. (1986) Biological, chemical and organoleptic changes during the maturation of farmed salmon, *Salmo salar*. Aquaculture. **53**:7-20

Bailey, J.E., and Ollis, D.F. (1986) Biochemical Engineering Fundamentals. Mc Graw-Hill International Editions. Chemical Engineering Series.

Bayley, S.T., and Morton, R.A. (1978) Recent developments in the molecular biology of extremely halophilic bacteria. Crit.Rev.Microbiol. **6**:151-205

Bejerkin, B., Storebakken, T., and Liaaen-Jensen, S. (1989) Pigmentation of rainbow trout with astaxanthin and canthaxanthin. Aquaculture. **90**(1):210

Bell, E.R., and White, E.B. (1989) Flowers and plants as sources of food colourants. Intl.Ind.Biotechnol. **9**(3):609-614

Bendich, A., and Oldson, J.A. (1989) Biological actions of carotenoids. FASEB J. **3**:1927

Bernhard, K., Muller, R.K., and Spruijtenberg, R. (1986) Cyclohexane derivatives, and processes for making same. U.S.Patent. No. 4,555,855

Bernhard, K. (1991) Synthetis of Astaxanthin-The route of a carotenoid from research to commercialisation. *In* Carotenoids, Chemistry and Biology.

Bitzer, R.R. (1963) For brighter colours in trout. U.S.Trout News. July/August. pp3

Bluhm, R., Branch, R., Johnston, P., and Stein, R. (1990) Aplastic anaemia associated with canthaxanthin ingested for tanning purposes. J.A.M.Assoc. **264**(9):1141-1142

Bobkova, T.S. (1965) Carotenoid pigments of Mycobacteria and yeasts. Mikrobiologiya (English translation). **34**:229-233

Borowitzka, L.J., and Borowitzka, M.A. (1990) Commercial production of β -carotene by *Dunaliella salina* in open ponds. Bull.Marine.Soc. **47**(1):244-235

Bramley, P.M., and Mackenzie, A. (1988) Regulation of carotenoid biosynthesis. Curr.Topics.Cell.Reg. **29**:291

Broger, E.A., Crameiri, Y., Leuenberger, H.G., Widmer, E., and Zell, R. (1981) Process for the manufacture of cyclohexane derivatives. U.S.Patent. No. 4,283,559

Brown, T.E., Richardson, F.L., and Vaughn, M.L. (1967) Development of red pigmentation in *Chlorococcus wimmeri* (*Chlorophyta:Chlorococcales*). Phycologia. **6**:167-184

Bubrick, P. (1991) Production of astaxanthin from *Haematococcus*. Bioresource Technology. **38**:237-239

Buchwald, M., and Jencks, W.P. (1968) Optical properties of astaxanthin solutions and aggregates. Biochemistry. **7**(2):324-398

Calo, P., de Miguel, T., Valasquez, J.B., and Villa, T.G. (1995) Mevalonic acid increases trans-astaxanthin and carotenoid biosynthesis. Biotechnology Letters. **17**(6):575-578

Calo, P., and Gonzalez, T. (1995) The yeast *Phaffia rhodozyma* as an industrial source of astaxanthin. Microbiologia Sem. **11**:386-388

Calo, P., Valasquez, J.B., Sierio, C., Blanco, P., Longo, E., and Villa, T.G. (1995) Analysis of astaxanthin and other carotenoids from several *Phaffia rhodozyma* mutants. J.Agric.Food.Chem. **43**:1396-1399

Calo, P., deMiguel, T., Siero, C., Valasquez, J.B., and Villa, T.G. (1996) Ketocarotenoids in halobacteria:3-hydroxy-echinenone and trans-astaxanthin. J.Appl.Bacteriol. **79**:282-285

Chapman, J.W., Marsden, W., and Maume, K. (1992) Astaxanthin-generating yeast cells. European Patent. Publ.No. 0474347 A1

Chien, Y.M., and Jeng, S.C. (1992) Pigmentation of kuruma prawn *Panaeus japonicus* Bate by various pigment sources and feeding levels. Aquaculture. **102**:333-346

Choubert, G. (1979) Tentative utilisation of spirulin algae as a source of carotenoid pigments for rainbow trout. Aquaculture. **18**:135-143

Chun, S.B., Chin, J.E., Bai, S., and An, G.H. (1992) Strain improvement of *Phaffia rhodozyma* by protoplast fusion. Letters of the Federation of European Microbiological Societies (FEMS). **93**(3):221-226

Craik, C.A., and Harvey, S.M. (1986) The carotenoids of eggs of wild and farmed Atlantic salmon and their changes during development to the start of feeding. J.Fish Biology. **29**: 548-566

Crozier, G.F. (1974) Pigments of fish. In Chemical Zoology. Florkin, M., and Scheer, B.T. (ed). Volume 8, chapter **13**:509-521

Czezuga, B. (1981) The presence of carotenoids in some invertebrates of the Antarctic coast. Comp.Biochem.Physiol. **69B**:611-615

Czygan, F.C. (1968) Sekunder-Carotinoide in Grunalgen. I. Chemie, Vorkommen und Faktoren, Welche die Bildung dieser Polyene beeinflussen. Arch.Mikrobiol. **61**:81-102

DeBoer, L., Van Hell, B., and Krouwer, A. (1993) Novel strains of *Phaffia rhodozyma* containing low levels of HDCO. Intl.Patent. Appl.No. WO 93/12249

Dentice Di Accadia, F., Gribanovski-Sassu, O., and Lozano Rayes, N. (1968) Blushing effect of some carbohydrates on the green alga *Dictyococcus cinnabarius*. Experimanta. **24**:1177-1179

DeRitter, E., and Purcell, A.E. (1981) Carotenoid analytical methods. *In* Carotenoids as colourants and Vitamin A precursor. Academic Press, New York. pp815-925

Droop, M.R. (1955) Carotenogenesis in *Haematococcus pluviialis*. Nature. **175**:42-46

Evans, C.T., Adams, D., and Wisdom, R.A. (1991) Yeasts and their use in astaxanthin production. European Patent. Application No. 90311254.8 (Enzymatix Ltd.).

Elliot, A. (1934) Morphology and life-history of *Haematococcus pluviialis*. Arch.Protistenk. **82**:250-272

Fang, T., and Cheng, Y-Shin. (1993) Improvement of astaxanthin production by *Phaffia rhodozyma* through mutation and optimisation of culture conditions. Journ.Fermentation and Bioengineering. **75**(6):466-469

FAO Fisheries Circular No.815 (1991) Aquaculture Production. Rome, Italy.

Fleno, B., Christensen, I., and Larsen, R. (1988) Astaxanthin-producing yeast cells, methods for their preparation and their use. Intl.Patent. Appl.No. WO 88/08025

Foss, P., Storebakken, T., Scheidt, K., Liaaen-Jensen, S., Austreng, E., and Streiff, K. (1984) Carotenoids in diets for salmonids. I. Pigmentation of rainbow trout with the individual optical isomers of astaxanthin in comparison with canthaxanthin. Aquaculture. **41**:213-226

Foss, P., Storebakken, T., Austreng, E., and Liaaen-Jensen, S. (1987) Carotenoids in diets for salmonids. V. Pigmentation of rainbow trout with astaxanthin and astaxanthin dipalmitate in comparison with canthaxanthin. Aquaculture. **65**:293-304

Fujita, T., Satake, M., Watanbe, T., Kitajima, C., Miki, W., Yamaguchi, K., and Konosu, S. (1983) Pigmentation of cultured red sea bream with astaxanthin diesters purified from krill oil. Bull.Jap.Soc.Sci.Fish. **49**(2):1855-1861

Gentles, A.S., and Haard, N.F. (1991) Pigmentation of rainbow trout with enzyme-treated and spray-dried *Phaffia rhodozyma*. The Prog.Fish. Culturist. **53**(1):1-6

Gibbons, N.E. (1969) Isolation, growth and requirements of halophilic bacteria. *In* Methods in Microbiology. Norris, J.R., and Ribbons, D.W. (ed). Volume **3B**: pp169-183 Academic Press, London.

Girard, P., Falconnier, B., Bricout, J., and Vladescu, B. (1996) β -carotene producing mutants of *Phaffia rhodozyma*. Appl.Microbiol.Biotech. **41**:183-191

Glover M., Morton, R.A. and Rosen, D.G. (1952) Astaxanthin Cholesterol and Lipids in developing salmon eggs. Biochem J. **50**: 425-429

Golubev, W.I., Babjeva, I.P., Blagodatskaya, V.M., and Reshetova, I.S. (1977) Taxonomy of yeasts isolated from the sap of birch (*Betula verrucosus* Eeh.). Mikrobiologiya. **46**:564-568

Goodwin, T.W. (1951) Carotenoids in fish. Biochem.Soc.Symp. **6**:63-80

Goodwin, T.W. (1972) Carotenoids in fungi and non-photosynthetic bacteria. Prog.Ind.Microbiol. **11**:29-88 Hockenhull, D.J.D. (ed).

Goodwin, T.W. (1984) Biochemistry of Carotenoids. Volume 2. *In* *Animals*. Second edition, Chapman and Hall, London.

Goodwin, T.W. (1992) Distribution of Carotenoids. *In* Methods in Enzymology. Volume **213**-Carotenoids Part A, Chemistry, Separation, Quantitation and Antioxidation. Packer, L. (ed). pp167-172

Grant, S.M., Healy, M.G., and Murphy, W.R. (1994) Effect of carbon concentration on astaxanthin synthesis during growth of the fermentative yeast *Phaffia rhodozyma*. Icheme Research Event.

Grung, M., deSouza, F.M., Borowitzka, M.A., and Liaaen-Jensen, S. (1992) Algal carotenoids. 51. Secondary carotenoids. 2. *Haematococcus pluviialis* aplanospores as a source of (3S,3'S)-astaxanthin esters. J.Appl.Phycol. **4**:165-171

Gueho, E., Kurtzman, C.P., and Peterson, S.W. (1989) Evolutionary affinities of heterobasidiomycetous yeasts estimated from 18S and 25S ribosomal RNA sequence divergence. Syst.Appl.Microbiol. **12**:230-240

deHaan, A., Burke, R.M., and deBont, J.A.M. (1991) Microbial production of food colourants. Med.Fac.Landbouww.Rijksuniv.Gent. **56**(4a):1655-1660

Haard, N.F. (1988) Astaxanthin formation by the yeast *Phaffia rhodozyma* on molasses. Biotech.Letters. **10**(9):609-614

Hari, P., Patel, K., and Martin, A.M. (1992) A new strain of *Rhodotorula rubra* isolated from yogurt. J.Ind.Microbiol. **11**:43-51

Hari, R.K., Patel, T.R., and Martin, A.M. (1994) An overview of pigment production in biological systems: Functions, biosynthesis and applications in the food industry. Food Reviews Intl. **10**(1):49-70

Harvey, R.W., and Stickney, R.R. (1992) Carotenoid pigmentation of salmon and trout. University of Washington, Seattle.

Harvey, D., and Larsen, V.F. (1995) *Phaffia rhodozyma* as a source of the red pigment astaxanthin for farmed salmon. Icheme Research Event. First European Conference. pp1082-1084

Hata, M., and Hata, M. (1973) Studies on astaxanthin formation in some freshwater fishes. Tohoku J.Agr.Res. **24**(4):192-196

Hata, M., and Hata, M. (1975) Carotenoid pigments in the rainbow trout (*Salmo gairdneri irideus*). Tohoku.J.Agr.Res. **26**:35-40

Hayman, G.T., Mannarelli, B.M., and Leathers, T.A. (1995) Production of carotenoids by *Phaffia rhodozyma* grown on media composed of corn wet-milling co-products. Feedstuffs. **14**:389-395

Herbert, V. (1991) Canthaxanthin toxicity. Am.Journ.Clin.Nut. **53**:573-578

Higgs, D., Donaldson, E., Dosanjh, B., Chambers, E.A., Shamaila, M., Skura, B., and Furukawa, T. (1995) The case for *Phaffia rhodozyma*. Northern Aquaculture. March/April:20-24

Hildingstam, J. (1976) Economics of research and development in the sea farming of salmonid species. Fish Farming Intl. March. pp 16-19

Howell, B.K., and Matthews, A.D. (1991) The carotenoids of wild and blue disease affected farmed tiger shrimps (*Panaeus monodon* (Fabricus)). Comp.Biochem.Physiol. **98B**:375-379

Hsieh, L.K., Lee, T.C., Chichester, C.O., and Simpson, K.L. (1974) Biosynthesis of carotenoids in *Brevibacterium* sp.KY-4313. J.Bacteriol. **118**:385-393

Ibrahim, A., Schimizu, C., and Kono, M. (1984) Pigmentation of cultured red sea bream, *Chrysophrys major*, using astaxanthin from Antarctic krill, *Euphausia superba*, and a mysid *Neomysis* sp. Aquaculture. **38**:45-47

Isler, O. (1971) Introduction. In *Carotenoids*. Isler, O. (ed). Birkenhauser-Verlag, Basel, Switzerland.

Jackson, A. (1988) Growth, nutrition and feeding. In *Salmon and Trout Farming*. Laird, L.M., and Needham, T. Ellis Horwood Ltd.

Jacobsen, G., Jolly, S.O., Sedmak, J., Skatrud, T., and Wasileski, J. (1995) Astaxanthin over-producing strains of *Phaffia rhodozyma*. Intl.Patent. Appl.No. 5,466,599

Johansen, J.E., Svec, W.A., and Liaaen-Jensen, S. (1974) Carotenoids of the *Dinophyceae*. Phytochemistry. **13**:2261-2270

Johnson, E.A.. (1978) Astaxanthin production by the yeast *Phaffia rhodozyma*, and its uses as a pigment source in animal feeding. M.Sc Thesis. Dept. of Food Science, University of California, Davis, California.

Johnson, E.A., Villa, T.G., Lewis, M.J., and Phaff, H.J. (1978) Simple method for the isolation of astaxanthin from the basidiomycetous yeast *Phaffia rhodozyma*. Appl.Environ.Microbiol. **35**(6):1155-1159

Johnson, E.A., and Lewis, M.J. (1979) Astaxanthin formation by the yeast *Phaffia rhodozyma*. J.Gen.Microbiol. **115**:173-183

Johnson, E.A., Villa, T.G., Lewis, M.J., and Phaff, H.J. (1979) Lysis of the cell wall of the yeast *Phaffia rhodozyma* by a lytic enzyme complex from *Bacillus circulans* WL-12. J.Appl.Biochem. **1**:273-282

Johnson, E.A., Lewis, M.J., and Grau, C.R. (1980) Pigmentation of egg yolks with astaxanthin from the yeast *Phaffia rhodozyma*. Poultry Science. **59**:1777-1782

Johnson, E.A., and An, G.H. (1991) Astaxanthin from Microbial Sources. Crit.Reviews Biotechnol. **11**(4):297-326

Johnson, E.A., Schreiber, D., Ho, P.K., Hall, W.T., Yang, H.H., and Geldiay-Tuncer, B. (1991) Processes for in vivo production of astaxanthin and *Phaffia rhodozyma* yeast of enhanced astaxanthin content. PCT Patent. Intl.Pub.No. WO 91/02060

Johnson, E.A. (1992) New advances in astaxanthin production by the yeast *Phaffia rhodozyma*. In Profiles and Biotechnology. Villa, T.G., and Abalde, J. (ed). pp289-299 Universidade de Santiago de Compostela.

Johnson, E.A., Schreiber, D., Kwok, P., Ho, P.K., Hall, W.T., Yang, H.H., and Geldiay-Tuncer, B. (1993) Processes for in vivo production of astxanthin, and *Phaffia rhodozyma* yeast of enhanced astaxanthin content. U.S. Patent. Appl.No. 5,182,208

Johnson, E.A, and Schroeder, M. (1995) Astaxanthin from the yeast *Phaffia rhodozyma*. Studies in Mycology. **38**: 81-90

Kamata, T., Tanaka, Y., Yamada, S., and Simpson, K.L. (1990) Study of carotenoid composition and fatty acids of astaxanthin diester in rainbow trout (*Salmo gairdneri*) fed the *Adonis* extract. Nippon.Suisan.Gakkaishi. **56(5)**:789-794

Katayama, T., Shimaya, M., Sameshima, M., and Chichester, C.O. (1973) The biosynthesis of astaxanthin. XII. The conversion of labelled β -carotene-15 into body astaxanthin in the lobster (*Panulirus japonicus*). Intl.J.Biochem. **4**:223-226

Katsuyama, M., Komori, T., and Matsuno, T. (1987) Metabolism of three stereoisomers of astaxanthin in the fish rainbow trout and tilapia. Comp.Biochem.Physiol. **86B**:1

Katsuyama, M., and Matsuno, T. (1988) Carotenoid and Vitamin A, and metabolism of carotenoids; β -carotene, canthaxanthin, astaxanthin, zeaxanthin, lutein and tunaxanthin in *Tilapia nilotica*. Comp.Biochem.Physiol. **90B**:131-139

Khare, A., Moss, G.P., Weedon, B.C.L., and Mathews, A.D. (1973) Identification of astaxanthin in Scottish salmon. Comp.Biochem.Physiol. **45B**:971-973

Koh, M., Kim, S.M., and Chun, S.B. (1992) Construction of astaxanthin over-producing strains of *Phaffia rhodozyma* by protoplast fusion. Microbiol.Biotechnol. **2(1)**:46-49

Knaemitsu, T., and Aoe, H. (1958) Studies on the carotenoids of salmon. I. Identification of the muscle pigments. Bull.Jap.Soc.Fish. **24(3)**:209-215

Knaemitsu, T., and Aoe, H. (1958) On the studies of carotenoids of salmon. II. Determination of muscle pigment. Bull.Jap.Soc.Fish. **24**:555-558 Krinsky, N.I., Matthews-Roth, M.M., and Taylor, R.M. (ed). Plenum Press, New York. pp 337-368

Krinsky, N.I., and Deneke, S.M. (1982) Interaction of oxygen and oxy-radicals with carotenoids. J.Natl.Cancer.Inst. **69**:205

Krinsky, N.I. (1989) Antioxidant functions of carotenoids. Free Radical.Biol.Med. **7**:617-638

Kuo, H.C., Lee, T.C., Kamata, T., and Simpson, K.L. (1976) Red crab processing waste as a carotenoid source for rainbow trout. Alimenta. **15**:47-51

Kurashige, M., Okimasu, E., Inoue, M., and Utsumi, K. (1990) Inhibition of oxidative injury of biological membranes by astaxanthin. Physiol.Chem.Phys.and Med. N.M.R. **22**:27-38

Kvalheim, B., and Knutson, G. (1985) Pigmentering av laks med astaxanthin fra mikroalger. Norsk.Fiskeo.Pdrett. **3**:4

Lambertsen, G., and Braekkan, O.R. (1971) Method of analysis of astaxanthin and it's occurrence in some marine products. J.Sci.Food.Agric. **22**:9

Lanyi, J.L. (1974) Salt dependant properties of proteins from extremely halophilic bacteria. Bacteriol.Review. **38**:272-290

Leathers, T.D., Gupta, S.C., Hayman, G.T., Rothfus, J.A., Ahlgren, J.A., Imam, S.H., Wu, Y.V., and Ggreene, R.V. (1992) New value-added co-products from biofuel conversions. Proc.U.S.-Japan Natural Resources Protein Panel 21st Annual Meeting. ppB1-B7

Leathers, T.D., and Hardy, R. (1995) Fish pigments can be produced from ethanol byproduct. Feedstuffs. **10**:10

Lee, R.G., Neamtu, G.G., Lee, K.C., and Simpson, K.L. (1978) Pigmentation of rainbow trout with extracts of floral parts from *Tagetes erecta* and *Circubita maxima marica*. Rev.Roum.Biochem. **15**(4):287-293

deLeenheer, A.P., and Nelis, H.J. (1991) Microbial sources of the carotenoid pigments used in foods and feeds (A review). J.Appl.Bacteriol. **70**:181-191

Lewis, M.J., Ragot, N., Berlant, M.C., and Miranda, M. (1990) Selection of astaxanthin overproducing mutants with β -Ionone. Appl.Environ.Micro. **56**(9):2944-2945

Lin, H.M., Chan, E.C., Chen, C., and Chen, L.F. (1991) Disintegration of yeast cell walls by pressurised carbon dioxide. Biotechnol. **7**:201-204

Little, A.C., and Martinsen, C. (1979) Colour assessment of experimentally pigmented rainbow trout. Colour Research and Applic. **4**(2):92-95

Long, A., and Haard, N.F. (1988) The effects of carotenoid-protein association on pigmentation and growth rates of rainbow trout. Proc.Aqua.Assoc.of Canada. St.Andrews, N.B.

Longo, E., Sierio, C., Valasquez, J.B., Calo, P., Cansado, J., and Villa, T.G. (1992) Astaxanthin production from *Phaffia rhodozyma*. Biotech.Forum.Europe. **9**(9):565-567

Lyons, T.P. (1990) Miscellaneous products from yeast (product information sheets). Alltech Biotechnology Centre, Kentucky, U.S.A.

Lwoff, M., and Lwoff, A. (1930) Determination experimentale de la synthese massive de pigment carotinode par le flagelle *Haematococcus pluvialis*. CR.Seances.Soc.Biol.Paris. **105**:454-461

Mackinney, G., Nakayama, T., Chichester, C.O., and Biss, C.D. (1953) Biosynthesis of carotene in Phycomyces. J.Am.Chem.Soc. **75**:236-238

Maoka, T., Katsuyama, M., Kaneko, N., and Matsuno, T. (1985) Stereochemical investigation of carotenoids in the Antarctic krill *Euphausia superba*. Bull.Jpn.Soc.Sci.Fish. **51**:1671

March, B.E., Hajen, W.E., Deacon, G., Macmillan, C., and Walsh, M.G. (1990) Intestinal absorption of astaxanthin, plasma astaxanthin concentration, body weight and metabolic rate as determinants of flesh pigmentation. Aquaculture. **90**:313-323

Martin, A.M., Acheampong, E., and Patel, T.R. (1993) Production of astaxanthin by *Phaffia rhodozyma* using peat hydrolysates as a substrate. J.Chem.Tech.Biotechnol. **58**:223-230

Mawson, R. (1992) Pigments. PCT Intl.Patent. No. WO/92 01754

May, J.B. (1987) Wet-Milling: process and products. *In* Corn, Chemistry and Technology. Watson, S.A., and Ramstead, P.E. (ed). pp377-397

Mayer, H.J., and Miller, R.K. (1981) Process for producing astaxanthin. U.S Patent. No. 4,245,109

McDermott, J.C., Brown, D.J., Britton, G., and Goodwin, T.W. (1974) Alternative pathways of zeaxanthin biosynthesis in *Flavobacterium* species. Experiments with nicotine as an inhibitor. Biochem.J. 144:231

Meyers, S.P., and Rutledge, J.E. (1971) Economic utilisation of crustacean meals. Feedstuffs. 43:46

Meyers, S.P., and Rutledge, J.E. (1971) Shrimp meal-a new look at an old product. Feedstuffs. 49:31-32

Meyers, S.P., Rutledge, J.E., and Sonu, S.C. (1973) Variability in proximate analysis of different processed shrimp meals. Feedstuffs. Nov.12. pp34-35

Meyers, S. (1977) Using crustacean meals and carotenoids in fortified diets. Feedstuffs.49:26-27

Meyer, P.S., and duPreez, J.C. (1993) Effect of acetic acid on astaxanthin production by *Phaffia rhodozyma*. Biotechnology Letters. 15(9):919-924

Meyer, P.S., and duPreez, J.C. (1994) Photo-regulated astaxanthin production by *Phaffia rhodozyma* mutants. System.Appl.Microbiol. 17:24-31

Meyer, P.S., and duPreez, J.C. (1994) Astaxanthin production by a *Phaffia rhodozyma* mutant on grape juice. World Journal of Microbiol.and Biotechnol. 10:178-183

Meyer, P.S., duPreez, J.C., and Van Dyk, M.S. (1994) The effect of Monoterpenes on astaxanthin production by *Phaffia rhodozyma*. Biotechnology Letters. 16(2):125-128

Meyer, P.S., Wingfield, B.D., and du Preez, J.C. (1994) Genetic analysis of astaxanthin over-producing mutants using RAPD's. Biotechnol.Techniques. **8**(1):1-6

Miki, W. (1991) Biological functions and activities of animal carotenoids. Pure Appl.Chem. **63**:141-146

Miller, M.W., Yoneyama, M., and Soneda, M. (1976) *Phaffia*, a new yeast genus in the Deuteromycotina (Blastomycetes). Int.J.Syst.Bacteriol. **26**:286

Mills, D. (1989) Ecology and management of Atlantic salmon. Chapman and Hall.

Mitza-Schnabel, U. (1980) The sub-cellular distribution of carotenoids in *Neospora crassa*. Phytochemistry. **19**:1409-1413

Mori, T., Makabe, K., Yamaguchi, K., Konosu, S., and Atai, T. (1989) Comparison between krill astaxanthin diester and synthesised free astaxanthin supplemented to diets in their absorption and deposition by juvenile coho salmon (*Oncor hynchus kisutchi*). Comp.Biochem.Physiol **93B**:255

Nagy, A., Garamszegi, N., Vagvolgyi, C., and Ferenczy, L. (1994) Electrophoretic karyotypes of *Phaffia rhodozyma* strains. FEMS. **123**:315-318

Nagy, A., Valvolgyi, C., and Ferenczy, L. (1995) Simple method for obtaining chromosomal DNA for Orthogonal Field Alternation Gel Electrophoresis Analysis from *Phaffia rhodozyma*. Biotechnol.Techniques. **18**(1):63-65

Nakayama, T., McKinney, G., and Phaff, H.J. (1954) Carotenoids in asprogenous yeasts. Antonie van Leeuwenhoek. J.Microbiol.Serol. **20**:217-228

Nakayama, T.O. (1962) Carotenoids. *In* Physiology and Biochemistry of algae. Lewin, R.A.(ed). Academic Press, New York. pp 409

Nakazoe, J. (1982) Application of High Performance Liquid Chromatography to the analysis of carotenoid pigments. Bull.Jap.Soc.Sci.Fish. **48**(7):1007

Nelis, H.J., and deLeenheer, A.P. (1989) Microbial production of carotenoids other than β -carotene. *In* Biotechnology of Vitamins, Pigments and Growth Factors. Van Damme, E.J. (ed). Elsevier Press, New York. pp 43

Nelis, H.J., and deLeenheer, A.P. (1989) Reinvestigation of *Brevibacterium* sp. strain KY-4313 as a source of canthaxanthin. Appl.Environ.Microbiol. **55**:2505

Nelles, L.P., and Wegner, E.H. (1993) Treatment of *Phaffia rhodozyma*. European Patent Application. No. 05538141

Ninet, L., Renaut, J., and Tissier, R. (1969) Activation of the biosynthesis of carotenoids by *Blakeslea trispora*. Biotech.Bioeng. **11**:1195

Novo Bioindustries Product Sheet for Novozyme 234. (1992) Novo Bioindustries, Denmark.

Nuttall, R. (1996) Personal communication. Quality Control Department, Roche Vitamins and Chemicals, Hertfordshire, U.K.

Okagbue, R.N., and Lewis, M.J. (1983) Mixed culture of *Bacillus circulans* WL-12 and *Phaffia rhodozyma* on different carbon sources:Yeast wall lytic enzyme production and extractibility of astaxanthin. Biotech.Letters. **5**(11):731-736

Okagbue, R.N., and Lewis, M.J. (1984) Autolysis of the red yeast *Phaffia rhodozyma*:A potential tool to facilitate the extraction of astaxanthin. Biotechnol.Letters. **6**(4):247-250

Okagbue, R.N., and Lewis M.J. (1984) Inhibition of the red yeast *Phaffia rhodozyma* by saponin. Appl.Micro.Biotechnol. **20**:278-280

Okagbue, R.N., and Lewis, M.J. (1984) Use of alfalfa residual juice (ARJ) as a substrate for propagation of the red yeast *Phaffia rhodozyma*. Appl.Environ.Micro. **20**:33-39

Okagbue, R.N., and Lewis, M.J. (1985) Influence of mixed culture conditions on yeast cell-wall hydrolytic activity of *Bacillus circulans* WL-12, and on extractability of astaxanthin from the yeast *Phaffia rhodozyma*. Journ.Appl.Bacteriology. **59**:243-255

Ostrander, J., and Martinsen, C.. (1976) Sensory testing of pen-reared salmon and trout. J.Food.Sci. **41**:386-390

Palozza, P., and Krinsky, L. (1992) Astaxanthin and canthaxanthin are potent antioxidants in a membrane model. Arch.Biochem.Biophys. **297**:291-295

Palagyi, Zs., Nagy, A., Vagvolgyi, Cs., and Ferenczy, L. (1995) A new mutation protocol for obtaining auxotrophic mutants of the yeast *Phaffia rhodozyma*. Biotechnology. **9**(6):401-402

Peebles, F. (1909) The life history of *Sphaerella lacustris* with special reference to the nature and behaviour of zoo-spoes. Cantralb.Backteriol.Parasitenk.Infek.Krankh. **24**:511-521

Pfander, H. (1992) Carotenoids:An overview. *In* Methods in Enzymology. Volume **213**. Carotenoids, Part A, Chemistry, Separation, Quantitation and Antioxidation. Packer, L. (ed). pp3-13

Phaff, H.J., Miller, M.W., Yoneyama, M., and Soneda, M. (1972) A comparative study of the yeast floras associated with trees on the Japanese Islands, and on the west coast of N.America. Appl.Environ.Microbiol. **26**:286

Phaff, H.J. (1986) My life with yeasts. Annual Rev.Microbiol. **40**:1

Phaff, H.J. (1990) Isolation of yeasts from natural sources. *In* Isolation of Biotechnological Organisms from Nature. Lapeda, D.P. (ed). pp53 McGraw Hill, New York.

PoLulyakh, O.V., Podoprigova, O.I., Eliseev, S.A., Ershov, Yu. V., Bykhovskii, V.Ya., and Dmitrovskii, A.A. (1990) Biosynthesis of Torulene and Torularhodin. Prikladnaya Biokhimiya Mikrobiologiya. **27**(4):541-545

Prevatt, W.D., Dickson, T.D., Vineyard, K.M., Harris, R.L., and Just, D.K. (1991) *Phaffia rhodozyma* mutants that overproduce astaxanthin. Research and Development Report. Phillips Petroleum Company, Oklahoma, U.S.A. (Obtained from the author). pp1-51

Prevatt, W.D. (1991) Various Extraction Techniques for Astaxanthin from *Phaffia rhodozyma*. Internal Report. Phillips Petroleum Company, Oklahoma, U.S.A. pp.2-26

Prevatt, W.D. (1992) Spheroplast fusions of *Phaffia rhodozyma* cells. Intl.Patent. Appl.No. 91117908.3

Prevatt, W.D. (1994) Personal communication. Phillips Petroleum Company, Oklahoma, U.S.A.

Prince, E. (1916) On the red colour of the flesh in salmon and trout. Trans.Am.Fish.Soc. **46**:5-61

Ravinder, P.K., Patel, T., and Martin, A.M. (1995) Growth and pigment production by *Rhodotorula rubra* and *Phaffia rhodozyma*. Journ. Basic Micro. **34**:44-48

Ravinder, P., Sangha, K., Patel, T., and Martin, A.M. (1995) Growth and pigmentation in *Rhodotorula rubra* and *Phaffia rhodozyma*. J.Basic.Microbiol. **35**(1):53-56

Renstrom, B., Borch, G., Skulberg, O., Aareskjold, K., Liaaen-Jensen, S., Vecchi, M., Leuenberger, F., Muller, R.K., and Mayer, H. (1980) Natural occurrence of enantiomeric and meso-astaxanthin. I. Ex.lobster eggs (*Hommarus gammarus*). Helv.Chim.Acta. **63**:711

Renstrom, B., and Liaaen-Jensen, S. (1981) Fatty acid composition of some esterified carotenoids. Comp.Biochem.Physiol. **69**:625-627

Rorstad, G., Robertson, B., and Rae, J. (1992) Process for enhancing the resistance of aquatic animals to disease. European Patent. Appl.No. 91111143.3. Pub.No. EPO 466 037

Rose, A.H. (1987) Yeast culture, a micro-organism for all species. A theoretical look at its mode of action. Alltech's Third Annual Symp. Biotechnology in the Feed Industry. Kentucky,U.S.A. pp113-119

Rosenberry, B. (1993) World Shrimp Farming. Shrimp News Intl. San Diego, California.

Rumsey, G.L. (1988) Fish Farming as a form of animal agriculture: Recent Advances in Fish Nutrition. Proceedings Alltech. 4th Symp:Biotechnology in the Feed Industry. pp235-238

Saito, A., and Regier, L.W. (1971) Pigmentation of brook trout (*Salvelinus fontinalis*) by feeding dried crustacean waste. J.Fish.Res.Board of Canada. **28**(4):509-512

Sanderson, G.W., and Jolly, S. (1994) The value of *Phaffia* yeast as a feed ingredient in salmonid feed. Aquaculture. **124**:193-200

Santopietro, L., Spencer, J.F.T., Spencer, D.M., and Sineriz, P. (1995) Formation of protoplasts from *Phaffia rhodozyma*. Biotechnol.Techniques. **9**(5):339-344

Savolainen, J.E.T., and Gyllenberg, H.G. (1970) Feeding of rainbow trout with *Rhodotorula sarneei* preparations. 3. Amounts and qualities of carotenoids. Lebensm-Wiss.U.Technol. **3**:18-20

Scheidt, K., Leuenberger, F.J., and Vecchi, M. (1981) Natural occurrence of enantiomeric and meso-astaxanthin. V. Ex wild salmon (*Salmo salar* and *Onchorynchus*). Helv.Chim.Acta. **64**:449

Scheidt, K., Leuenberger, F.J., Vecchi, M., and Glinz, E. (1985) Absorption, retention, and metabolic transformations of carotenoids in rainbow trout, salmon, and chicken. Pure Appl.Chem. **57**(5):685-692

Scheidt, K., Foss, P., Storebakken, T., and Liaaen-Jensen, S. (1989) Metabolism of carotenoids in salmonids. I. Idoxanthin, a metabolite of astaxanthin in the flesh of Atlantic salmon (*Salmo salar L*) under varying external conditions. Comp.Biochem.Physiol. **92B**(2):277-281

Scheiner, D. (1976) Determination of ammonia and Kjeldahl nitrogen by the Indophenol method. Water Res. **10**(1):31-36

Schneider, R., Hardy, R.W., and Brannon, E.L. (1979) The use of dietary supplements to improve the flesh colour of salmonids. *In* Research in Fisheries. Annual Report of the College of Fisheries, University of Washington, Seattle. pp67

Schutte, M., and Kula, M. (1990) A review-Pilot and process scale techniques for cell disruption. Biotech.Appl.Biochem. **12**:599-621

Segner, H., Arend, P., von Poeppinghausen, K., and Schmidt, H. (1989) The effect of feeding astaxanthin to *Oreochromis niloticus*, and *Colisa lebrisa* on the histology of the liver. Aquaculture. **79**:381-390

Simpson, K.L. (1977) The recovery of protein and pigments from shrimp and crab meals, and their use in salmonid pigmentation. Proc.of the First Intl.Conf.on Chitin/Chitosan. Mass.Institute.Tech. pp253-262

Simpson, K.L., Katayama, T., and Chichester, C.O. (1981) Carotenoids in fish feeds. *In* Carotenoids as Colourants and Vitamin A precursors. Academic Press, New York.

Sinnot, R. (1988) Fish Pigmentation. Trout News. **7**:8-11

Skrede, G., and Storebakken, T. (1986) Characteristics of colour in raw, baked and smoked wild and pen-reared salmon. J.Food.Sci. **51**(3):804-809

Spencer, J.F.T., Spencer, D.M., and Bruce, I.J. (1989) Yeast Genetics, a Manual of Methods. Springer-Verlag, New York.

Spencer, K.G. (1989) Pigmentation supplements for animal feed compositions. U.S.Patent. No.4,871,551

Spencer, K.G. (1989) Pigmentation supplements for animal feed compositions. PCT Intl.Patent. No. WO 89/06910

Spiegel, M.R. (1988) Outline of theory and problems of statistics *In* Schaums Outline Series. Second edition. pp90-188 Mc Graw-Hill, London.

Spinelli, J., Lehman, L., and Wieg, D. (1974) Composition, processing and utilisation of the red crab (*Pleuroncodes planipes*) as an aquacultural feed ingredient. J.Fish.Res.Board of Canada. **31**:1025-1029

Spinelli, J., and Mahnken, C. (1978) Carotenoid deposition in pen-reared salmonids fed diets containing oils of the red crab (*Pleuroncodes planipes*). Aquaculture. **13**:213-224

Steven, D.M. (1948) Studies on animal carotenoids: Carotenoids of the brown trout (*Salmo trutta linn.*). J.Exp.Biol. **25**:369

Storebakken, T., Foss, P., Austreng, E., and Liaaen-Jensen, S. (1985) Carotenoids in diets for salmonids. 2. Epimerization studies with astaxanthin in Atlantic salmon. Aquaculture. **44**:251-269

Storebakken, T., Foss, P., Scheidt, K., Austreng, E., Liaaen-Jensen, S., and Manz, U. (1987) Carotenoids in diets for salmonids. 4. Pigmentation of Atlantic salmon with astaxanthin, astaxanthin dipalmitate and canthaxanthin. Aquaculture. **65**:279-292

Storebakken, T. (1988) Krill as a potential feed source for salmonids. Aquaculture. **70**:193

Straub, O. (1976) Key to Carotenoids. *In* List of Natural Carotenoids. Birkhauser-Verlag, Basel.

Sumner, J.B., and Somers, F. (1949) Laboratory experiments in biological chemistry. Academic Press, New York.

Tacon, A.G. (1981) Speculative review of possible carotenoid functions in fish. Prog.Fish Culturist. **43**(4):205-208

Tanaka, Y. (1978) Comparative biochemical studies on carotenoids in aquatic animals. Mem.Fac.Fish. Kagoshima University, Japan.

Terao, O. (1989) Antioxidant activity of β -carotene related carotenoids in solution. Lipids. **24**:659-661

Tilseth, S., Hansen, T., and Moller, D. (1991) Historical development of salmon culture. Aquaculture. **98**:1-10

Torregrossa, R., and Prevatt, W.D. (1991) A process for producing astaxanthin in *Phaffia rhodozyma*. European Patent. Application No. 91106436.8 Pub.No. 0454024 A2

Torrissen, O.J. (1984) Pigmentation of salmonids-Effect of carotenoids in eggs and start-feeding diet on survival and growth rate. Aquaculture. **43**:185-19

Torrissen, O.J. (1985) Pigmentation of salmonids:Factors affecting carotenoid deposition in rainbow trout (*Salmo gairdneri*). Aquaculture. **46**:133-144

Torrissen, K.R., and Torrissen, O.J. (1985) Protease activities and carotenoid levels during the sexual maturation of Atlantic salmon (*Salmo salar*). Aquaculture. **50**:112-122

Torrissen, O.J., and Naedval, G. (1988) Pigmentation of salmonids-Variation in the flesh carotenoids of Atlantic salmon. Aquaculture. **68**:305-310

Torrissen, O.J., Hardy, R.W., and Shearer, K.D. (1989) Pigmentation of salmonids-carotenoid deposition and metabolism in salmonids. Crit.Rev.Aquatic. Sci. **1**:209

Van Ooyen, A.J. (1994) Transformation of *Phaffia rhodozyma*. Intl.Patent. Appl.No. WO 94/06918 (Gist-Brocades, N.V.).

Villadsen, I.S. (1992) A method of generating high carotenoid-producing micro-organisms, micro-organisms obtained by the method, and a process for producing carotenoid containing cells or cells parts, or purified carotenoid. Intl.Patent. Appl.No. WO 92/22648

Watanbe, T., Itoh, A., Murakami, A., Tsukashima, Y., Kitajima, C., and Fujita, S. (1984) Effect of nutritional quality of diet given to broodstock on the verge of spawning; on the reproduction of red bream. Jpn.Soc.Sci.Fish. **50**:1023-1028

Wettern, M., and Weber, A. (1979) Some remarks on algal carotenoids and their conversion into animal carotenoids. *In* Marine Algae in Pharmaceutical Science. Hoppe, E.A., Lerner, T., and Yanaka, T. (ed). Walter de Gruyter and Company, Berlin. pp551-570

Weijman, A.C., deMiranda, L.R., and van der Walt, J.P. (1988) Redefinition of *Candida* Berkhout and the consequent emendation of *Cryptococcus* Kutzing and *Rhodotorula* Harrison. Antonie.van Leeuwenhoek.J.Microbiol.Serol. **54**:545-560

Winzler, R. (1941) The respiration of Bakers yeast at low oxygen tension. Journ.Cell and Comp.Physiol. **17**(3):263-277

Wollenweber, W. (1971) Untersuchungen uber die Algengattung *Haematococcus*. Ber.Deutsch.Bot.Ges. **26**:238-298

Yamada, Y., and Kawasaki, H. (1989) The genus *Phaffia* is phylogenetically separate from the genus *Cryptococcus* (*Cryptococcaceae*). Agric.Biol.Chem. **53**:2845

Zeichmeister, L. (1962) Cis-trans isomeric carotenoids, Vitamin A and Arylpolyenes. Academic Press, New York. pp51-55