

LEVERAGING THE GREEN ECONOMY: RECOVERING CONTAMINATED WOOD AS PALLET BLOCKS

A.Dimache¹, D. Kearney², S. Clery², P. Donohoe³

1. Mechanical Engineering Department, Galway-Mayo Institute of Technology. Dublin Road, Galway. Ireland.
2. Palfab Ltd., Macroom, Co.Cork. Ireland.
3. Eirebloc, Macroom, Co.Cork. Ireland.

ABSTRACT

The market for clean wood has been growing in the last years; however, waste wood hasn't been considered a resource mainly because it usually arises as part of a mixed waste stream and it is predominantly contaminated, which often makes recovery impractical. Large quantities of waste wood are being discarded to landfill every year, which represent a significant missed opportunity. The CleanWood LIFE project is offering an innovative solution to wood recovery and identifies uses for all co-products. This paper presents the successful vision separation technology the project has developed to detect and isolate contaminated woodchip. All residues from the process are used: clean wood as boiler fuel for the CHP system, the remaining contaminated wood for the manufacturing of composite pallet blocks, ferrous/non-ferrous materials, stone, glass and plastics for recycling.

KEYWORDS: wood recovery, vision separation technology, sustainability

1. INTRODUCTION

Contaminated wood arising from construction and demolition, packaging or other sources is a massive problem in Europe. Frequently, it is discarded to landfill or can be used only in very restricted applications. Contamination is caused by the presence of metals (nails etc.), paint, solvents (such as creosote), stones, mortar, plastics or even soil.

Within the contaminated timber (such as, for example, a length of timber used for supporting a window frame while being set), generally only small areas are actually contaminated. The purpose of this paper is to describe how to recover a significant portion of the overall material mass such that it can be used for clean wood applications. The CleanWood LIFE Environment project, promoted by Palfab Ltd., a timber processor from near Macroom, Co. Cork, developed a process to enable this recovery. This process shreds the contaminated material into small wood chips, selectively removes foreign materials (stones, metals etc) through a series of automated sorting processes, and finally uses a high precision vision system for locating and extracting residual contaminated chips (e.g. those with paint etc.). Significantly, the residues from the process are almost all recoverable, e.g. stones and metals can be recycled, the discarded wood after final sorting can be used in low level applications, such as composite blocks, while the cleaned wood can be used for wood pellets, horse gallops, animal bedding etc. The only element discarded for landfill is unsorted residues composed of plastics and other untraceable materials.

The paper commences in Section 2 by presenting the driving factors for wood recovery. Then, in Section 3, the CleanWood separation process is described and the novelty of the system is highlighted. The innovative technology for manufacturing compressed pallet blocks using contaminated waste wood and waste tyre-derived materials is briefly presented in this section also. Section 4 proves the sustainability of the CleanWood activity through outlining the results of a Life Cycle Assessment study.

2. WHY WOOD RECOVERY?

The EU is very sensitive to environmental issues and opportunities and has a number of programmes, such as LIFE and ECO-Innovation, which promote new innovative methods for reducing, reusing or recycling waste materials. One such waste material is wood, particularly from the construction and demolition and packaging sectors.

2.1 Sources of Wood Waste and its Uses

Waste wood can come from various sources such as:

- municipal solid waste streams, pallets, the construction and demolition industries, deconstruction, land clearing and primary timber processing
- wood spools & railroad ties [1]
- wood from furniture [1]
- telegraph poles and railway sleepers [2].

Once recovered, it can be used in a variety of applications such as engineered wood products and composites, compost, wooden pallets, animal bedding, furniture manufacture, boiler fuel, packaging filler [1], [3], [4]. Although recovered wood can be used for so many industrial purposes, it is currently mostly used in the production of particleboard and fibreboard [4]. The other possible utilisation options for recycling of recovered wood as a solid material are of minor significance. In order to provide appropriate consumer protection and to prevent the accumulation of hazardous substances, the recovered wood that can currently be used generally as a secondary raw material and in wood based panel production in particular has to be limited to the non-hazardous fractions. Those fractions of untreated and uncontaminated recovered wood can also be traded within the European internal market. E.g. a particleboard mill in Portugal fulfils a considerable part of its demand for raw material with recovered wood transported from Eastern Germany via Baltic and North Sea [4].

2.2 Benefits of Wood Recovery

Wood recovery is a new and growing industry that is developing due to rising timber prices, diminishing space in landfills, and specialty markets for antique woods [5]. With the world's current demand for forest products, use of already-existing wood products that would otherwise go to landfills greatly reduces the need to harvest virgin woods.

Wood recovery has many **benefits for the environment**, including [1], [3], [4], [6]:

- It expands and extends the life of the wood fibre supply
- It contributes to carbon storage
- It reduces environmental depredation and emissions
- It reduces the amount of wood going to landfills
- It contributes to the development of technologies utilising a variety of recoverable wood fibres
- It converts low-value solid waste wood into higher-value products

- The European Union set a target to increase the share of renewable energy in the European primary energy supply from a level of 12% in 2010 to 20% by 2020. One of the most important sources of biomass – in addition to forestry and energy crops - derives from industrial wood at the end of its life (e.g. demolition wood, timber from building sites and the commercial sector)
- The estimation of 50-100 million tonnes of recovered wood in Europe has an energy content of about 750-1,350 PJ (PetaJoules), depending on its moisture content. Thus, the use of recovered wood for energy generation could contribute significantly to two major policy goals of the European Union. On the one hand, such use would contribute to doubling the share of renewable energy in the European primary energy supply to 12% by 2010 and on the other hand, being a virtually CO₂ neutral energy source, it would help meet the reduction of EU GHG emissions as declared within the Kyoto protocol. The substitution of coal with the above amount of recovered wood could lead to a reduction of 75 – 135 million tonnes of CO₂ per year [4].

Wood recovery is good for the environment, while offering **economic benefits** as well [1]:

- It avoids disposal costs
- It is a source of revenue to offset processing cost
- It offers competitive advantage to companies
- It means positive public relations
- The average price of raw, unrefined waste wood is about 25€/tonne, while that for clean wood is approximately 40-60€/tonne [5]
- With the ever-increasing amount of waste and with the aim of returning waste to the economic system through recovery, it is believed that the market will continue to show growth in the next several years.

2.3 Wood Recovery in Ireland

In Ireland, the market for wood recovery is very strong. It is estimated that 111,014 tonnes of wood packaging arose in 2008 (almost 10% of packaging), of which 98.9% was recovered [7]. Around 4% of the construction and demolition waste in Ireland was wood in 2008 and the whole quantity was recovered (78,336 tonnes) [7]. Some **driving factors for the wood recovery** in Ireland are:

- Landfill costs are rising
- Ireland exhibits a significant energy import dependency (90.9% in 2007) [8]
- It can help reduce CO₂ emissions and thus meet the Kyoto limit – Ireland's target is to limit the increase in its greenhouse gas emissions under the Kyoto Protocol to 13% above 1990 levels by 2008-2012 [9]
- More stringent landfill and packaging waste regulations. At present there are two pieces of legislation that have an impact on wood disposal and resources available [10]:
 - *The Landfill Directive* (1999/31/EC) and subsequent amendments (2003, 2006) restricts the quantity of biodegradable waste entering landfill, as a means to reduce greenhouse gas emissions. Whilst wood is not targeted directly, it is a constituent of household waste, and as such is covered by the directive.
 - *The Packaging Directive* (94/62/EC) and subsequent amendments (2004, 2005) restricts the amount of wood used in packaging – for example pallets and packing crates – that can be disposed of either to landfill or incineration without energy recovery. The directive sets recycling and recovery targets for the quantity of wood used for packaging (19.5% in 2006).

3. THE CLEANWOOD PROCESS

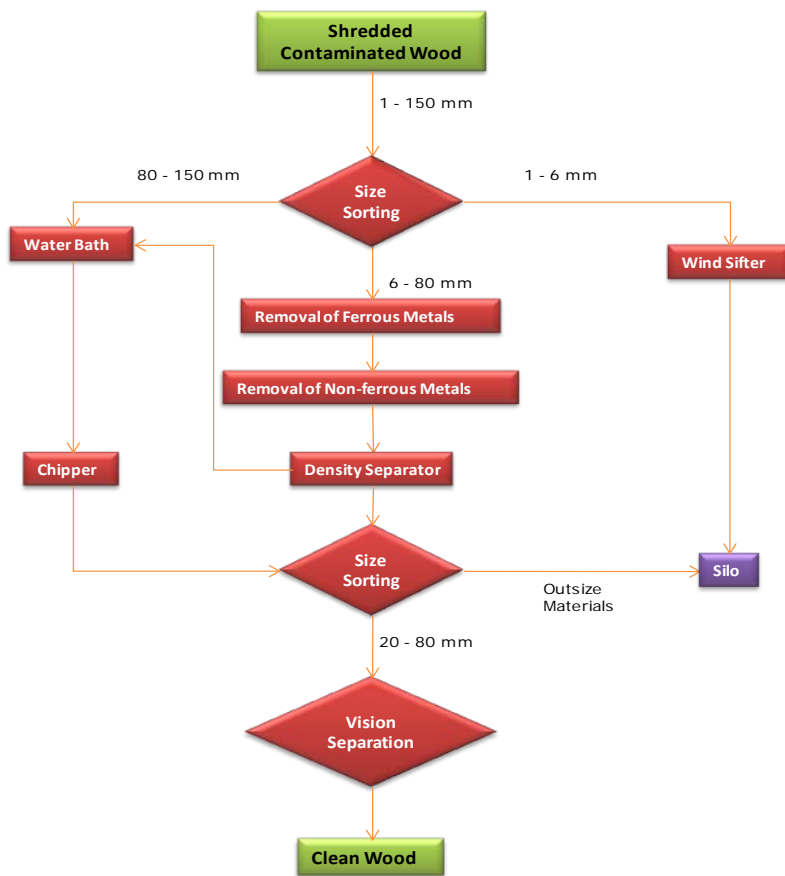

Figure 1 Material separation steps for wood chips

separated by examining each individual woodchip, assessing its quality and making a determination on whether it is clean or contaminated.

3.1 Mechanical Separation

Mechanical separation involves several processes, each designed to remove one or more gross levels of contaminants:

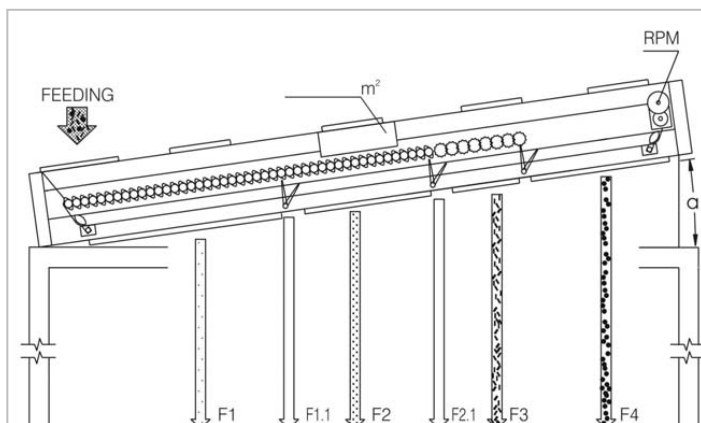

Figure 2 The Dyna-screen process

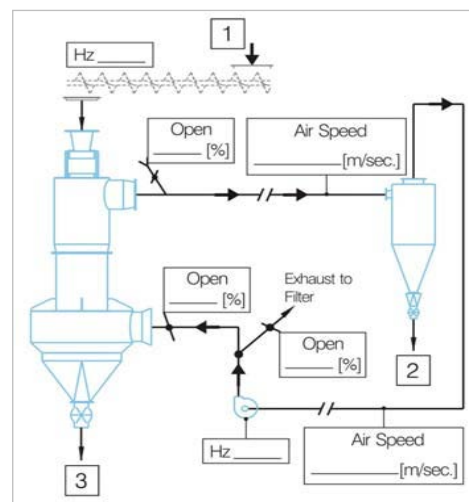

Figure 3 The wind sifter

In response to the above-mentioned drivers for wood recovery, the CleanWood LIFE Environment project has been developing a demonstrator to process waste wood in order to remove contaminants such that the resulting wood can be certified as ‘clean’. The prime source of materials is construction and demolition timbers, which are currently being supplied from local authority processing centres.

The CleanWood process involves several material separation steps for wood chips (see Figure 1). The initial steps carry out gross separation of contaminants such as ferrous and non-ferrous metals, plastics, stones and sand. After this separation, the remaining contaminants are those which either are absorbed by the wood chips (i.e. pressure treated) or which adhere to the chips (such as paint). These can only be

1. The **Dyna-screen** (see Figure 2) identifies and separates the woodchip into bundles of similar sized material. It is fed on to a series of rollers where it is conveyed on a slight incline. The distance between the rollers increases in stages as the material is conveyed along. The woodchip falls through the opening which first presents an appropriate size and shape.
2. The **wind sifter** (see Figure 3) receives the fine material (1), which is comprised of chips of uniform size and weight, from the Dyna-screen. By passing this fine material through a stream of compressed air, it can be separated (2) from heavier contaminants such as aggregate. This enables the lighter woodchip to be channelled away from the heavier contaminants (3) through a system of ducts.
3. **Metal separation** (see Figure 4). A machine named IGM is designed to purge the residual woodchip of all metal contaminants. Ferrous metals are removed using a magnetised roller conveyor belt concept. Non ferrous metals are separated by the use of eddy-currents.

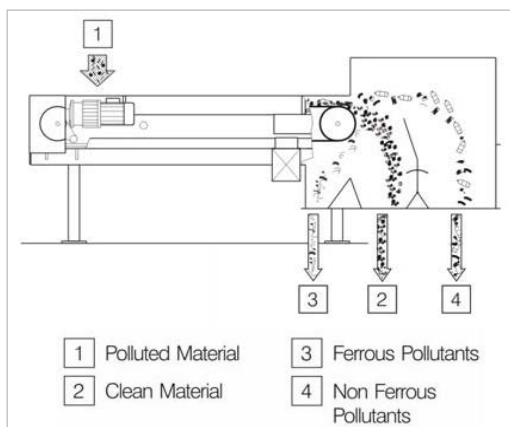

Figure 4 Metal separation

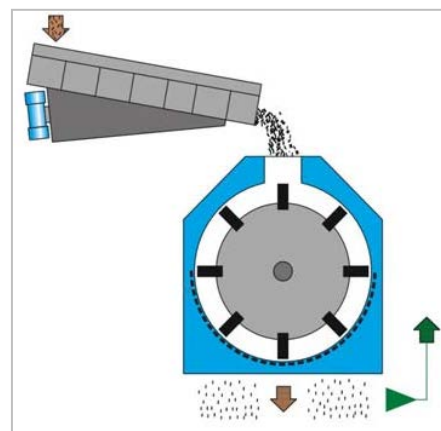

Figure 5 The hammermill

4. **Hammermill** (see Figure 5). The oversized woodchip from the Dyna-screen test is required to be reduced to smaller chip sizes and subsequently re-graded using a hammermill. The material is then reprocessed through the system.

3.2 Vision Separation

By the time the woodchip gets to the vision separator, it has already been cleansed of all physical contaminants (stones, metals, plastics). What remains is primarily chemical treatments, such as paint, creosote and other solvents. A vision system was developed in order to detect this final contamination element. The vision system includes a high resolution colour camera, with a bespoke software package for image analysis, coupled to an air-based removal system for expelling contaminated chips.

Material from the final output of the electro/mechanical sorting equipment is fed on to the vision analysis conveyor where it is passed under the digital imaging camera. This camera takes multiple images per second (depending on the conveyor speed). These images are scanned and processed by the image analysis software package in milliseconds (see Figure 6). Once foreign contaminants are identified, a signal is sent to a PLC, which operates one of twelve air knives located at the end of the conveyor to remove the required contaminants. The air knife blows out all of the material within the signalled location. This will, of necessity, include some amount of 'clean' material. This is deemed preferable in order to ensure that all contaminants are removed. The continuing challenge is to achieve a level of False Accepts as close to zero as possible (False

Accepts is where contaminated material is not recognised by the system), while minimising the level of False Rejects (where clean material is identified as contaminated by the system).



Figure 6 Screenshot of the software programme for a cross sectional view of chips

Overall, the analysis conducted to date has been very encouraging. There has been a gradual improvement in the false accepts rate, though this needs to be improved further. The overall yield of good material from the process continues to improve, although it is still a long way from satisfactory.

3.3 Use of Rejected Material for Manufacturing of Compressed Pallet Blocks

While the rejected material cannot be certified as ‘clean’, nevertheless it still has a high level of purity and can be used for all applications except those which require its calorific potential to be realised (such as wood pellets) or where possible contaminants can leach into the soil (such as horse gallops) or be harmful to animals or humans (such as animal bedding).

A particular example of the use of the residual wood is for the manufacturing of compressed pallet blocks as evidenced by the new Eirebloc facility in Macroom, Co. Cork. This innovation consists of combining waste wood from the CleanWood process with tyre waste in the right proportions to deliver superior performance (compression strength, dimensional stability, resistance to weathering, insulation) through taking advantage of some of the characteristics of the tyre material, such as a greater damping effect, less brittleness and greater durability. Eirebloc manufactures pallet blocks through the use of an extrusion system which guarantees significantly better dimensional accuracy rather than the block moulding process used elsewhere in the industry. The Eirebloc facility will eventually have the capacity to produce 100,000 m³ of pallet blocks, all from recycled waste materials.

4. CLEANWOOD – A SUSTAINABLE ACTIVITY

A full analysis of the CleanWood project was carried out to demonstrate the technical, environmental and economic benefits of the innovative technology. This section will examine the environmental aspect of the project. An abridged quantitative LCA was carried out for the wood recovery process. The abridged LCA method was chosen because it is much quicker and more cost-effective in comparison to a full LCA. The method used is Eco-indicator 99 [11]. The study followed all the steps of an LCA: goal and scope definition, inventory analysis, impact assessment and interpretation [12].

4.1 The Study

The goal of the study was to use Life Cycle Assessment (LCA) to compare the impact on the environment of the wood recovery activity with the impact on the environment of landfill of

contaminated wood arising from construction, demolition or packaging. The results offer a basis for measuring environmental performance and can be used by Palfab Ltd. to improve the environmental performance of the CleanWood activity.

The study was carried out in and was based on specific data supplied by Palfab. Data supplied from Palfab's production and distribution functions consisted of information such as electricity consumption as well as any other types of energy or material consumption, waste and means of transportation. Other data (regarding production of raw materials, combustion of fuel etc.) was obtained from either the manufacturers or through research.

Only the recovery activity was investigated. The final product (the clean wood) was not followed till the end of life because it can have various uses (e.g. animal bedding, fuel, board plants, pellet plants) and therefore various impacts on the environment. The raw material (contaminated wood) used is diverted from landfill, thus avoiding landfill. It is not virgin raw material. It is coming from construction and demolition, packaging or other sources.

Data from Palfab, suppliers or research were interpreted and complemented as needed and allocated to the functional unit (the functional unit in an LCA is the basic mass used for the comparison of alternatives. In this case, the function unit was 2000 kg of clean wood). Then calculations were made to obtain the value of environmental indicators that show the impact on the environment of the wood cleaning activity. The results were interpreted.

The study concluded that **the wood recovery activity has an advantage (decreased environmental load) over landfill**. A negative value of the Eco-indicator was obtained (-445.27 mPt), which means a beneficial impact of the wood recovery activity on the environment. If the contaminated wood used in the cleaning process went to landfill, the impact on the environment would be 1149.88 mPt (considering only the end of life) which is high in comparison with the value of the eco-indicator for the wood recovery activity: -445.27 mPt. **Overall, the wood recovery activity is 'green'.**

4.2 Recommendations

Recommendations were made to improve the overall environmental performance of the wood cleaning activity and some actions have already been carried out in response:

1. Use waste wood as it has a lower impact on the environment than the use of virgin wood.

Action: Complete.

2. The highest impact on the environment is produced during transportation. Palfab should consider ways of reducing the impact on the environment produced during transportation of raw materials or finished products.

Action: Palfab Ltd. ensure that their suppliers of waste wood shred the materials prior to shipment to the company's premises. This ensures that the volume/tonne is minimised.

3. Another area of concern is energy consumption. The impact on the environment due to energy consumption is quite high. Palfab should consider alternative energy sources, which are more environmentally friendly.

Action: Palfab proposed a CHP (Combined Heat and Power) project; it has undergone feasibility analysis and is awaiting approval from the Sustainable Energy Authority of Ireland (SEAI).

4. The separation process is beneficial to the environment. However, PE goes to landfill. PE recycling should also be considered. That would reduce the environmental impact of the overall activity.

Action: Complete.

5. CONCLUSIONS

This paper has presented the innovative solution to wood recovery offered by the CleanWood project. The CleanWood project has proven that clean wood can be recovered from wood containing some contaminated elements. The project has developed a successful vision separation technology to detect and isolate contaminated woodchip and has also identified uses for all co-products: various uses of the clean wood (such as boiler fuel for their new CHP system), manufacturing of composite pallet blocks using the contaminated wood and tyre-derived materials, recycling of ferrous/non-ferrous materials, stone, glass and plastics. Further work needs to be carried out to improve the false reject rate which means a higher percentage of clean wood recovered by the system. This is crucial to making the process economically feasible.

The wood recovery activity has proved to be a sustainable activity. The analyses done during the project showed good environmental and economic performance of the activity. This paper briefly presented the results of the LCA carried out during the project which showed the benefits to the environment. This activity together with the manufacturing of compressed pallet blocks using contaminated wood can have a significant impact on preservation of forests and on landfill.

6. ACKNOWLEDGEMENTS

This paper is based on the LIFE-Environment demonstration project CleanWood (Project No. LIFE06 ENV/IRL/000532). The European Union made possible this demonstration by funding provided through the LIFE Programme.

7. REFERENCES

- [1] Kessler Consulting, Practical Approaches to Wood Waste Management & Recovery Programs. *11th Annual Rinker Conference*, Florida, 2003.
- [2] DTI, Wood Waste Arisings and Recycling Rates: Factsheet, Department of Trade and Industry, UK, 2003.
- [3] AF&PA, Renewable Energy, American Forest and Paper Association, 2009 <http://www.afandpa.org/>.
- [4] COST, Draft Memorandum of Understanding for the implementation of a European Concerted Research Action designated as COST Action E31: Management of Recovered Wood, European Cooperation in the field of Scientific and Technical Research, EU, Brussels, 2002.
- [5] CleanWood, CleanWood Progress Report no. 6, 2010.
- [6] OIT, Commercial Demonstration of Wood Recovery and Value Adding Technologies, Office of Industrial Technologies, US Department of Energy, 2002.
- [7] EPA Ireland, National Waste Report for 2008, 2009.
- [8] DG TREN, EU Energy in Figures, EU Directorate-General for Energy and Transport, 2008.
- [9] SEAI, Renewable Energy Policy Drivers, 2010 http://www.seai.ie/Renewables/Renewable_Energy_Policy/Policy_Drivers/.
- [10] European Commission, Waste, Environment, 2010 <http://ec.europa.eu/environment/waste/index.htm>.
- [11] PreConsultants, Eco-indicator 99: Manual for Designers, 2000 <http://www.pre.nl>.
- [12] ISO, ISO 14040: Environmental Management - Life Cycle Assessment - Principles and Framework, 2006.