

Behaviour of hybrid concrete lattice girder flat slab system using insitu structural health monitoring

Shane Newell^{1,5}, Jamie Goggins^{1,2,3,6}, Magdalena Hajdukiewicz^{1,2,3}, Dave Holleran⁴

¹ College of Engineering & Informatics, National University of Ireland, Galway, Ireland

² Ryan Institute, National University of Ireland, Galway, Ireland

³ Informatics Research Unit for Sustainable Engineering (IRUSE), National University of Ireland, Galway

⁴ Oran Pre-cast Ltd., Oranmore, Galway, Ireland

⁵ Galway-Mayo Institute of Technology, Galway, Ireland

⁶ Centre for Marine and Renewable Energy Ireland (MaREI), Galway, Ireland

email: s.newell2@nuigalway.ie

ABSTRACT: In recent decades, Structural Health Monitoring (SHM) has emerged as an increasingly important tool in Civil Engineering to understand how structures behave during construction and operation. Although SHM is not a new concept, it is only relatively recently that Civil Engineers have adopted SHM for the design, construction and management of civil engineering structures. One of the key benefits of SHM is the improved understanding of insitu structural behaviour.

This paper describes the SHM strategy implemented on a recently constructed building to monitor and record the behaviour of a hybrid concrete lattice girder flat slab floor system. Hybrid concrete construction (HCC) combines insitu and precast concrete to maximise the benefits of both forms of construction. HCC offers many advantages for both the designer and contractor and produces simple, buildable and economic structures which can result in faster, safer construction and reduced costs.

Sensors were embedded in both the precast and insitu components of the hybrid concrete floor system and are used to monitor various aspects of the behaviour of the floor during the manufacture, construction and operational phase of the building. The information from the real-time monitoring offers the opportunity to compare actual and predicted behaviour using structural codes, such as Eurocodes. The majority of the instrumentation is embedded within the structure so that long-term effects such as creep and shrinkage of concrete components can also be investigated.

KEY WORDS: Structural health monitoring; lattice girder flat slab, structural monitoring.

1 INTRODUCTION

This paper describes the implementation of a real-time structural health monitoring (SHM) scheme on a new building (Human Biology Building) under construction at the National University of Ireland, Galway (NUI Galway). This project is one of a number projects which forms part of a measurement framework strategy developed at NUI Galway to continuously monitor the structural and environmental performance of buildings during construction and operation [1, 2]. Although the building is currently under construction at the time of writing, some preliminary results from the project are presented in this paper.

A variety of sensors were embedded in the hybrid concrete floor structure of the building and are used to monitor various aspects of the behaviour of the floor during the manufacture, construction and operational phase of the building.

The overall objectives of this research project are:

- compare actual and predicted behaviour of the floor.
- analyse the long term behaviour of the floor.
- investigate construction and design parameters for potential optimisation of hybrid concrete floor system.
- develop and calibrate numerical models that predict the performance of the hybrid concrete floor system.

1.1 Structural Health Monitoring

SHM can be defined as ‘the use of *in-situ*, non-destructive sensing and analysis of structural characteristics, including the structural response, for purposes of estimating the severity of the damage and evaluating the consequences of the damage on

the structure in terms of response, capacity, and service-life [3]. Although the majority of SHM is related to civil infrastructure, in recent decades, it has emerged as an increasingly important tool in civil engineering for monitoring deterioration in concrete structures and predicting the future performance of structural components [4, 5]. It generally consists of continuous or periodic monitoring of a structure using sensors that are either embedded in it or attached to its exterior [6].

One of the key benefits of SHM is the improved understanding of insitu structural behaviour. The majority of design codes have been developed following research conducted in engineering laboratories where it can be very difficult to replicate the behaviour of real structures insitu. Consequently, testing and analysis is typically conducted on small-scale specimens which only partially represent the overall structure. SHM can be used to provide rich information on how real structures behave when subject to actual structural and environmental loads.

2 HUMAN BIOLOGY BUILDING

The Human Biology building (HBB) is a four storey building over basement and roof level plant enclosure with a gross floor area of 8200m² (Figure 1). This facility will encompass three schools; Anatomy, Physiology & Pharmacology and Therapeutics. The building will be a teaching and research facility with lecture theatres, laboratories, offices and meeting rooms. Construction commenced in January 2015 and the expected construction period is 19 months (July 2016). It is

anticipated that the building will achieve an A rating under the Commercial Energy Rating marking scheme and a BREEAM Excellent rating.



Figure 1. Human Biology Building (under construction)

The HBB is primarily constructed using precast concrete elements, including the building frame, twinwall system, hybrid concrete lattice girder slabs and hollowcore slabs, which were designed, manufactured and installed by Oran Pre-Cast Ltd.

2.1 Hybrid concrete lattice girder flat slab

Presently, the structural frame is substantially complete and external cladding and internal fit-out has commenced. The majority of the floor structure is 400mm thick and is constructed using a two-way spanning hybrid precast concrete lattice girder flat slab system. This consists of a 65mm thick precast lattice girder plank (Figure 2) and 335mm in-situ concrete topping. The lattice girder truss which protrudes from the plank provides stiffness in the temporary state and increases composite action with the in-situ structural concrete topping. The main bottom floor reinforcement is contained within the precast concrete plank and the top layer of reinforcement is placed on site along with a layer of stitching reinforcement across the joint between slabs, prior to pouring the insitu concrete topping. The precast planks are temporarily propped until the structural concrete topping has reached the required compressive strength.

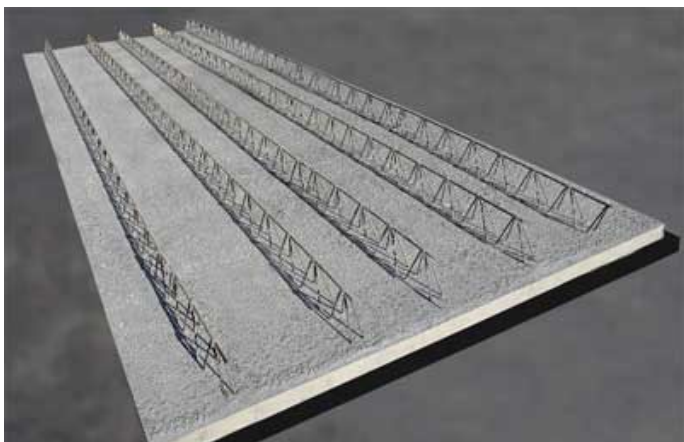

Figure 2. Precast Concrete Lattice Girder Plank(© Oran Pre-cast Ltd.)

Flat slabs are one of the most widely used forms of floor construction providing minimum structural depths, fast construction and uninterrupted service zones. Transportation and site handling limitations generally dictate the allowable sizes of the precast planks. The use of steel moulds results in a high-quality finish, which can be left exposed if required. The quality of the factory produced soffits also provides the opportunity to take advantage of the thermal mass properties of the concrete slab by exposing them. The main advantages of this floor system to the contractor are in terms of programme, reduction in steel fixing and formwork requirements on site.

The precast plank was manufactured using a C40/50 concrete mix with a CEM II A-V cement (370kg/m³ typically or 425kg/m³ if self-compacting concrete used). The mix design for the insitu concrete topping was C30/37 with 230kg/m³ of CEM I cement and 100kg/m³ of GGBS (i.e. 30%).

3 INSTRUMENTATION

3.1 Instrumentation

The SHM strategy implemented in the HBB used a number of sensors embedded in the floor structure to monitor the environmental and structural behaviour of the hybrid concrete lattice girder flat slab. Two zones in the second floor of the HBB were selected for instrumentation using a combination of vibrating-wire (VW) strain gauges, electrical resistance (ER) strain gauges and thermistors (Figure 3).

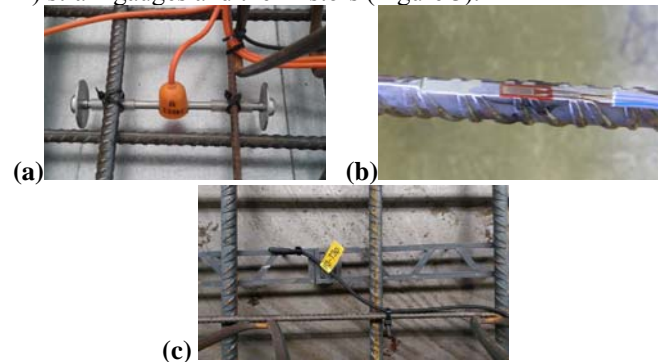

Figure 3. Sensors embedded in the buildings' structure: (a) VW Strain gauge in precast plank, (b) ER strain gauge on reinforcement, (c) Thermistor in precast plank

112 embedment VW strain gauges, manufactured by Gage Technique (Type TES/5.5/T), were installed in both the precast plank prior to manufacture and in the insitu concrete topping prior to pouring. The VW gauges measure both temperature and longitudinal strain in the concrete. These type of gauges were initially developed by the Transport and Road Research laboratory (TRRL) in the UK and are used extensively in bridge sections, tunnel linings and dam projects. They have a range of greater than 300 microstrain and resolution better than 1 microstrain. The temperature can be measured between -20°C and +80°C. These VW gauges are very robust and their stability makes them suitable for monitoring time dependent effects in concrete such as creep and shrinkage.

The VW gauges were positioned along a number of orthogonal grids in the floor structure at over 30 designated

locations so that two-way spanning behaviour of the floor structure could be monitored. At most locations, four VW gauges were positioned through the depth of the slab (1 in the precast plank and 3 in the insitu topping) so that the strain and temperature profile through the slab could be measured (Figure 4).

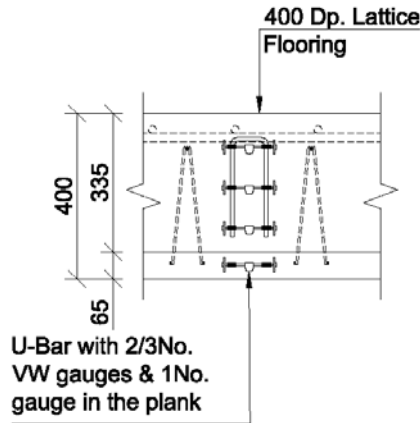

Figure 4. Typical section showing locations of vibrating wire gauge installed in the flat slab system.

To achieve two-way spanning behaviour in the floor structure, ‘stitching’ reinforcement bars are required across the joints between adjacent precast planks. The stitching bar is required to transfer the forces in the bottom transverse reinforcement bars across the joint and are positioned on site after the precast planks have been erected on site. Electrical resistance (ER) uniaxial strain gauges (Tokyo Sokki Kenkyujo model FLA-6-11-3LT, temperature compensating) were bonded to five stitching bars (H12 or H16) to measure the change in strain across the joint (Figure 5). Their gauge length is 6mm and they have a strain limit of 5%.

All ER gauges were protected using waterproof tape and sealant after bonding to the stitching bars to protect the gauges from the harsh environment (alkaline chemicals and pressurised water) when embedded in the concrete. Five individual ER gauges were bonded to each stitching bar so that the variation in strain along the stitching bar across the joint could be monitored.



Figure 5. ER strain gauges on stitching bar across joint in planks

In addition to the instrumentation embedded within the floor structure, the deformation of the plank soffit during the

construction phase was recorded at regular intervals using digital surveying. This will allow the measured strains using the embedded instrumentation to be related to the measured change in strain in the floor structure.

3.2 Data acquisition system

To collect data from the sensors, a data acquisition system containing CR1000 data loggers, AVW200 vibrating wire interface and AM16/32B multiplexers obtained from Campbell Scientific were employed. This system has been automatically logging data from the sensors embedded in the precast plank since manufacture and in the insitu concrete topping since their initial installation on site. During the construction phase, data is being stored on a flash memory card, which is manually downloaded onto a laptop weekly and backed-up on a server. However, data communication relay through the use of Campbell Scientific’s NL115 Ethernet and Compact Flash Module will allow data to be collected over a local network after this is set up on commissioning of the building. This will allow the long term behaviour of the floor structure to be monitored during the operational phase of the HBB.

3.3 Material Testing

To accurately predict the behaviour of concrete elements, it is critical that the properties of the concrete are determined as they will change over time depending on the environment and loading. A comprehensive material testing programme was undertaken to measure the properties of the precast and insitu concrete used in the floor structure. Concrete cylinders, cubes and prisms specimens were made and cured in water and in air (to match the environmental conditions of the floor structure). Density, compressive strength, tensile strength and modulus of elasticity of the concrete in the precast plank and insitu topping were recorded during the construction phase of the project.

The information from the material testing is used to interpret the data from the instrumentation and can also be used for modelling of the behaviour of the floor structure.

3.4 Environmental Conditions

The environmental conditions around the floor structure will impact on the behaviour of the concrete slab, particularly at early stages of curing. Air temperature and relative humidity in the vicinity of the instrumented slab were measured using the weather data from the NUIG weather station (located approximately 1km from the site). When building was enclosed a sensor was positioned inside the building to record the air temperature and relative humidity.

4 PRELIMINARY RESULTS

4.1 Early-age thermal effects

Nine VW strain gauges were embedded in one of the 65mm thick precast planks prior to manufacture and data was recorded immediately after the plank was cast. Data was continuously recorded for this plank during curing, delivery and erection on site so that strain and temperature history of the precast plank can be analysed throughout the life cycle of the product from cradle to end of life. The instrumented plank

was cast during the Summer (June) and temperature curing was not used by the precast manufacturer in this case.

The concrete temperature for the nine VW gauges embedded in the plank and the air temperature (dashed line) are shown in Figure 6(a) for the 7 days after the plank is manufactured. In the first 24 hours after casting (25th June 2015), the peak in the concrete temperature due to the heat of hydration is noted and contrasts with the falling ambient air temperature during the night. The peak in the concrete temperature occurs 10 hours after casting and the maximum difference between the air temperature and the concrete temperature is approximately 5.5°C. **It is noted that the peak temperature is slightly less for the three gauges located close to the perimeter of the plank (less than 300mm) as the plank cools more quickly along its external surfaces.** However, because the concrete plank is relatively thin (65mm), after the first 24 hours the concrete temperature in the plank is relatively uniform for all nine VW gauges and they correlate with the ambient air temperature.

This contrasts markedly with the concrete temperature in the insitu topping in which the heat of hydration is more significant because of the thickness of the concrete (335mm thick), as well as the insulating properties of the precast biscuit resulting in only one surface of the insitu concrete being exposed. The concrete temperature in the insitu topping at one location in which three VW gauges are embedded to measure strain and temperature through the concrete (top, middle and bottom) are shown in Figure 6(b). The temperature for the VW gauge in the precast plank at this location is also shown. For the first 7 days after pouring, the temperature in the concrete exceeds the ambient air temperature and it is only after 7 days that the heat generated from the hydration process has fully dissipated. The effect of the diurnal temperature changes are clearly visible in the measured temperature in the concrete floor. Similar to the precast plank, the peak in concrete temperature occurs 10 hours after casting and at this point, the maximum temperature differential between the air and concrete temperature is approximately 13°C. As expected, the peak temperature is recorded for the VW gauge in the middle of the insitu topping as the internal section of the slab will be slowest to cool down. The effect of the heat of hydration from the insitu topping on the concrete in the precast plank can be noted almost immediately after pouring and results in a peak increase in temperature of 9°C.

For 'thick' concrete sections (typically greater than 500mm), the temperature rise due to the heat of hydration can result in excessive thermal stresses and cracking generated by restraint to thermal movement. For the 335mm thick insitu topping in this project, the temperature differential through the slab is small (Figure 6(b)) because of the relatively thin section which allows the concrete to cool comparatively uniformly as the heat is readily lost to the environment. The temperature differential recorded by the VW gauges in top, middle and bottom of the insitu topping did not exceed 3°C and the maximum differential occurred during the cooling phase.

Predicting the potential for early-age thermal cracking is very difficult at the design stage because of numerous factors which affect the behaviour of the concrete and the limited

information on the concrete known at design stage. CIRIA Report C660 by Bamforth [7] gives guidance on predicting the early-age thermal behaviour of concrete sections based on a comprehensive testing programme undertaken at University Dundee [8]. However, the report recommends thermal modelling for reliable predictions which take account of the formwork and exposure conditions. Based on thermal modelling, it predicts that the maximum temperature differential in the insitu topping would be 13°C, but this figure is highly dependent on the thermal diffusivity of concrete, surface conditions and the environmental conditions (wind and solar gain).

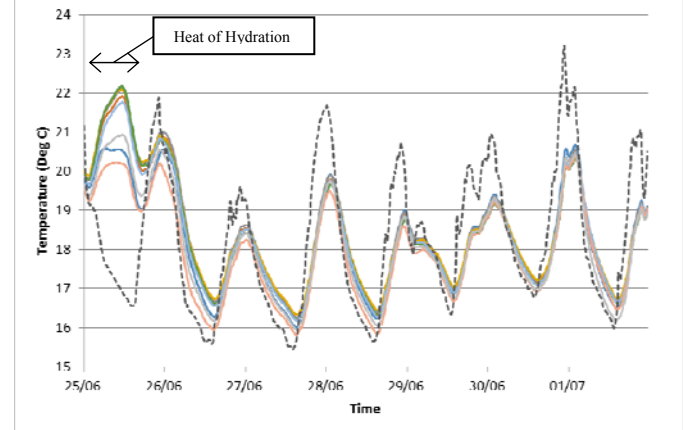

(a) 65mm precast plank

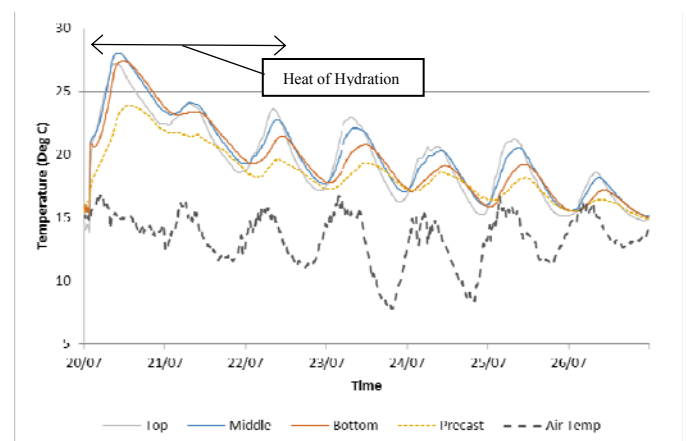

(b) 335mm insitu concrete topping

Figure 6. Concrete temperature after pour (7 days)

As an upper bound, Fitzgibbon [9] estimated that the peak temperature rise under adiabatic conditions is 12°C/100kg per cubic metre of concrete, regardless of the type of cement used. Therefore, assuming a 100% CEM I cement for the insitu topping, it could be expected that the peak temperature be as much 40°C (total cement content of insitu topping was 330kg/m³). However, in this project 30% GGBS was used as a cement replacement in the concrete mix and this would help to reduce the heat of hydration generated during curing. The predicted peak temperature differential for the insitu topping using CIRIA Report C660 [7] is approximately 19°C, but other factors which can affect the peak temperature are the variation between cements, placing temperature and actual thermal conductivity of the precast plank. The measured peak

temperature of 13°C equates to a temperature rise of 4°C/100kg per cubic metre of concrete. In terms of minimising cracks, the general rule of thumb used by designers is to limit temperature differentials to 20°C, although this figure is dependent on the type of aggregate used in the concrete mix. It can be seen from the above figures that the CIRIA report provides upper bounds for the peak temperature and temperature differentials for a specific concrete pour.

4.2 Strain and Temperature Profile

The strain and temperature profile in the precast planks and insitu topping is recorded using the embedded instrumentation so that the changes in strain during the manufacture of planks, delivery to site, pouring of insitu topping, during construction and operation phase can be analysed. The temperature profile for the nine VW gauges embedded in the same precast plank is shown in Figure 7 for the first 30 days after manufacture. As mentioned previously, following the cooling phase after manufacture, the temperature in the precast plank and air temperature are closely aligned and the diurnal temperature changes can be observed. When the precast plank was delivered to site on the 4th July 2015, the plank was exposed to direct sunlight and the ability of thin concrete plank to store and dissipate heat during the daily heating and cooling cycles is noted. In Figure 7, one can observe where the concrete temperature on some days in the precast plank prior to the pour is in excess of 12°C of the ambient air temperature during the day but returns to the ambient air temperature at night. These peaks in concrete temperature correlate with days of high solar irradiance as recorded by the NUIG weather station.

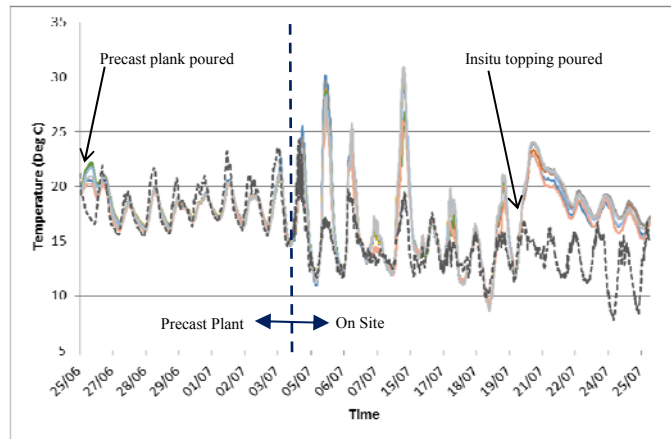

Figure 7. Temperature profile in precast plank (1 month)

The measured change in strain in the gauges in the precast plank when the insitu topping was poured on the 20th July 2015 was relatively small because the precast planks are propped (typically at 2.4m centres) during construction to limit deflection until the insitu topping has reached the required design strength.

The strain and temperature profile for three VW gauges through the depth of the insitu topping at one location is shown in Figure 8 for the first 7 days after pouring. After the dormant period of the hydration process, which lasted approximately 2 hours, there is a significant step change in tensile strain varying from 20µε near the bottom of the insitu

topping to 40 µε at the top of the insitu topping due to the heating phase and the resulting expansive strains. Typically, the measured strains are greater for the gauges near the top of the insitu topping in comparison with the gauges near the bottom of the insitu topping which may be partially explained by the restraining effect of the precast plank. After the cooling phase of the heat of hydration is finished (~2-3 days), thermal strains are significant and the concrete is subject to daily tensile and compressive strains in response to the diurnal ambient air temperature. The daily changes in strain due to thermal effects can be estimated by multiplying the coefficient thermal expansion of concrete (α_c) and the measured temperature change in the concrete. It should be noted that whilst the floor structure is propped the measured strain is a combination of thermal, shrinkage (autogenous and drying) and creep and further analysis is required to determine the magnitude of the various strain components.

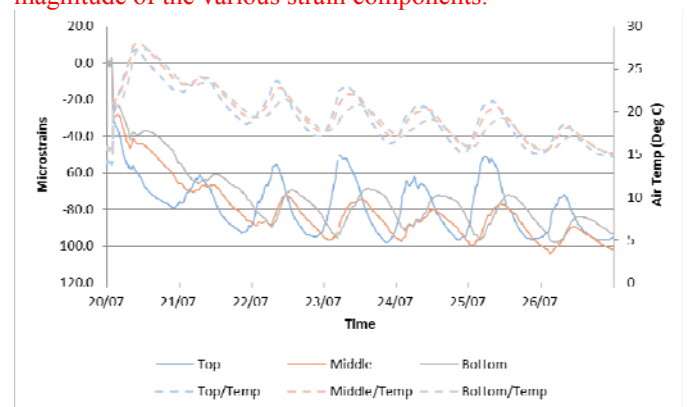

Figure 8. Strain and temperature profile in insitu topping (7 days)

4.3 Early-age cracking

During the early stages of curing, there is potential for cracking to occur if the tensile strain capacity of the concrete is exceeded. Some research has shown that microcracks can form even if 50% of the tensile strength of the concrete is exceeded [10]. The coefficient of thermal expansion of concrete (α_c) will determine the magnitude of thermal strain associated with a particular temperature change. Values for concrete vary from 8-13µε/°C depending primarily on the aggregate used. EN 1992-1-1 [11] recommends a value of 10µε/°C for normal weight concretes. However, a design value of 9µε/°C may be used for limestone aggregates [12] which were used for the concrete on the HBB project. Using the measured peak recorded temperature of 13°C, this equates to thermal strains of approximately 117µε in the insitu topping. Observations have shown that early-age cracking is most likely to occur within three to six days [13].

The tensile strain capacity of concrete, ϵ_{ctm} , is the maximum strain that the concrete can withstand without the formation of a continuous crack. Tensile strain capacity is not dealt with in EN 1992-1-1, but can be derived from values of the tensile strength and elastic modulus of the concrete provided in EN 1992-1-1. Tensile strain capacity under short-term loading can be approximated as the ratio of the mean tensile strength of concrete f_{ctm} to its mean elastic modulus E_{cm} and this has been shown to represent lower bound values [7].

$$\varepsilon_{ctu} = f_{ctm} / E_{cm} \quad (1)$$

The values derived for tensile strain capacity are increased by 23% to take account of the relaxation of stress due to creep and reduction in tensile strength under a sustained load [7]. The aggregate type is of particular significance to the tensile strain capacity as aggregate comprises about 70% of the concrete volume.

The strain profile in the insitu topping at one location in the slab for the first seven days is compared in Figure 9 with the theoretical tensile strain capacity given in Equation 1. The graph indicates the measured strain is close to or exceeds the theoretical strain capacity during the first 3 days after the pour. No cracking was observed in the location of the slab in which strain gauges were embedded and the actual tensile strain capacity of the insitu topping is at least 20-30% greater than the theoretical tensile strain capacity based on material testing conducted on concrete samples at 3 Days and 7 Days, which were air cured to match the environmental conditions on site. This illustrates the difficulty of predicting early-age cracking without accurate knowledge of the environment or material properties.

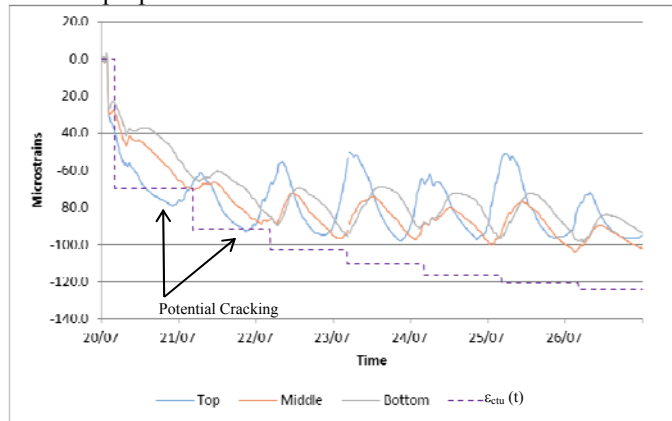

Figure 9. Comparison of measured strain and theoretical strain capacity (7 Days)

4.4 Construction stage behaviour

A hybrid concrete lattice girder flat slab structure was used to construct the ground to fourth floor of the HBB (the basement was constructed using insitu concrete). As mentioned previously, the precast planks are temporarily supported by props which are erected prior to installation of the planks. The precast planks acts as permanent formwork and contain the bottom reinforcement for the floor structure. As the concrete frame progressed upwards, the floors constructed below the floor under construction were used to support the self-weight of the next floor. A temporary works engineer was employed by the contractor to determine a back propping sequence for the floor structure at each level as construction progressed. The back propping sequence must ensure that the load from the wet concrete is transferred to a sufficient number of floors below so that no slabs are overloaded. When the compressive strength of the insitu topping had reached a specified strength, the supporting props were dropped and re-applied so that each slab was supporting its own self-weight.

During the construction phase of the HBB, the changes in strain when props were dropped, back-propped and removed

and floors were poured above second floor can be analysed. The deformation of the slab soffit during the construction phase was also recorded using a digital level. The change in strain along a gridline (GL H) in the second floor for a series of VW strain gauges in the top of the insitu topping at two loading events is shown Figure 10. The solid line is the change in strain when the third floor was poured (13th August 2015) and the dashed line is the change in strain when the props were dropped and re-propped 15 days later. The recorded strains shows that when the props were dropped from the third floor, so that it supports its own self-weight, that the imposed stresses on the second floor from the third floor pour are reversed.

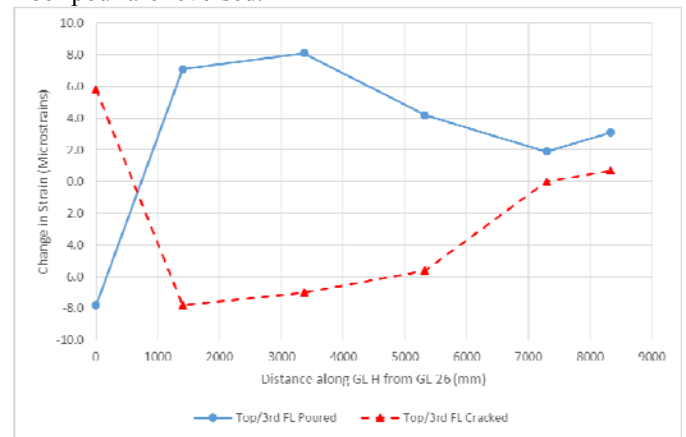

Figure 10. Measured change in strain along Gridline H

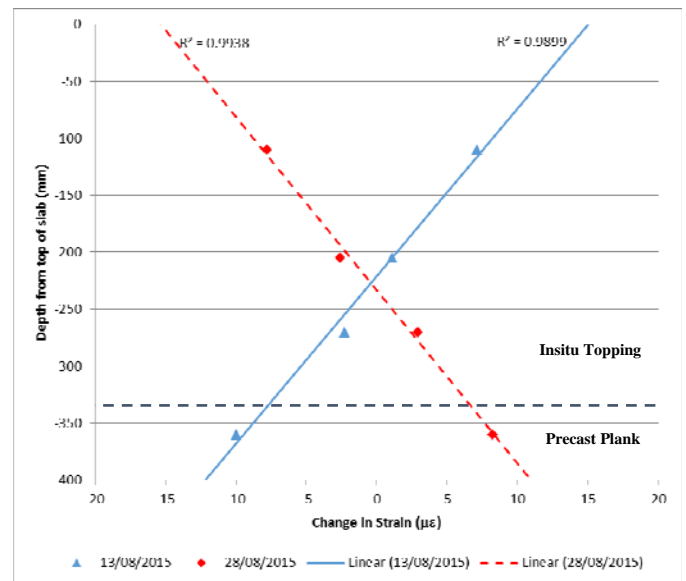

Figure 11. Strain profile through 400mm thick floor structure

The measured changes in strain through the 400mm thick floor structure at one location along gridline H is shown in Figure 11 when the third floor is poured (13th August 2015) and when the props supporting the third floor are dropped (28th August 2015). At this location, there are three VW gauges in the insitu topping and one VW gauge in the precast plank. The strain profile illustrates the composite nature of the hybrid concrete floor structure and also that the slab appears

to exhibit linear elastic behaviour at this stage of construction and could be considered ‘uncracked’.

5 CONCLUSIONS

This paper presents the motivation and implementation of a real-time structural health monitoring strategy for a hybrid concrete lattice girder flat slab floor system. The sensors installed allow many important aspects of the performance of the floor structure (structural, environmental etc.) to be monitored during the manufacture, construction and operational phase of the building. In combination with the material testing, weather monitoring station and laboratory testing, this SHM strategy provides rich information about the performance of the floor.

Design guidelines are typically approximations which simplify the behaviour of the structure so that it can be solved relatively quickly and simply. However, these approximations and simplifications have the potential to introduce errors or inaccuracies to the design process. The insitu instrumentation provides performance data on actual behaviour which can be used to verify design methods. Real-time monitoring offers potential benefits in relation to optimisation of structural components by understanding the actual behaviour of components in use and the possibility to develop and calibrate numerical models that predict structural performance.

The preliminary results presented in this paper are at an early stage and it is expected that the measured data will be used to compare actual behaviour with predicted behaviour using structural codes, such as the Eurocodes. Continuous monitoring of the data will allow long term effects in the structural performance of the slab to be monitored and compared with design guidelines.

ACKNOWLEDGMENTS

The authors would like to acknowledge the support of the European Commission Horizon 2020 project Built2Spec (637221). A great debt of gratitude is owed to all members of the project teams involved in the design and construction of the Human Biology Building who have facilitated our work throughout the project. A special mention is also owed to the technical staff at NUI Galway for their assistance during the instrumentation process. The support of Oran Pre-Cast Ltd. is gratefully acknowledged with respect to installation of sensors in the precast concrete elements. The second author would also like to acknowledge the support of Science Foundation Ireland through the Career Development Award programme (Grant No. 13/CDA/2200) and the National Centre for Marine and Renewable Energy Ireland (MaREI) (Grant no. 12/RC/2302).

REFERENCES

- [1] Goggins, J; Newell, S; King, D; Hajdukiewicz, M (2014) Real-time monitoring of a hybrid precast and in situ concrete flat slab system. *Proceedings of Civil Engineering Research in Ireland (CERI 2014)* Queens University Belfast, Northern Ireland, 321-326.
- [2] Hajdukiewicz, M., Byrne, D., Keane, M. M., & Goggins, J. (2015). Real-time monitoring framework to investigate the environmental and structural performance of buildings. *Building And Environment*, 86, 1-16.
- [3] Guan, H., Karbhari, V. M., & Sikorsky, C. S. (2006). Web-Based Structural Health Monitoring of an FRP Composite Bridge. *Computer-Aided Civil and Infrastructure Engineering*, 21(1), 39-56.
- [4] Habel, W. R. (2013). SHM systems supporting extension of the structures’ service life. *Journal of Civil Structural Health Monitoring*, 3(4), 225-226.
- [5] Chang, P. C., Flatau, A., & Liu, S. C. (2003). Review paper: health monitoring of civil infrastructure. *Structural health monitoring*, 2(3), 257-267.
- [6] Bisby, L. A., & Briglio, M. B. (2004). ISIS Canada Educational Module No. 5: An Introduction to Structural Health Monitoring. *Prepared by ISIS Canada*, 3.
- [7] Bamforth, P. B. (2007). Early-age thermal crack control in concrete. CIRIA Report C660, London.
- [8] Dhir, R. K., Paine, K. A., & Zheng, L. (2004). Design Data for Use where Low Heat Cements are Used. *Concrete Technology Unit, Dundee*.
- [9] Fitzgibbon, M. E. (1976). Large pours for reinforced concrete structures. *Current Practice Sheet 2P/15/1*, No. 28 *Concrete*, 10(3), 41.
- [10] FIB (1999) Structural Concrete Textbook on behaviour, design and performance, Second edition: Basis of design. International Federation for Structural Concrete, 1999
- [11] CEN (1992), ‘EN 1992-1-1, Eurocode 2: Design of concrete structures. General rules for buildings,’ ed. Brussels, Belgium, 1992.
- [12] Bamforth, P., Chisholm, D., Gibbs, J., & Harrison, T. (2008). Properties of concrete for use in Eurocode 2. *The Concrete Centre, UK*.
- [13] ALEXANDER, S. J. (2006). Why does our concrete still crack and leak? *The Structural Engineer*, 84 (23/24) 2006, 40-43. London.